

MB-Gateway

Sit back, relax and enjoy your climate

SALDA

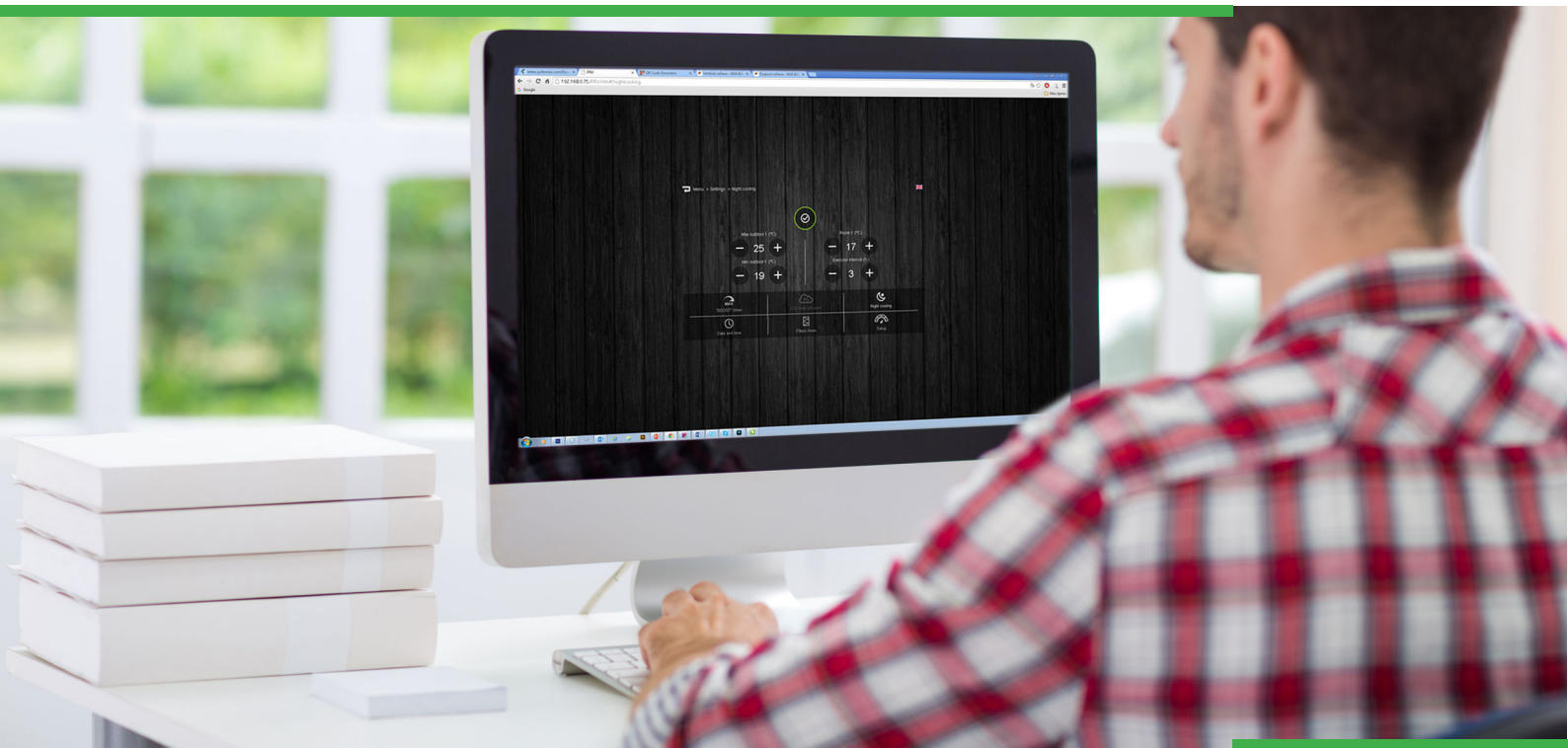

Act smarter! To control your climate, choose MB-Gateway by Salda UAB:

- › Remote air handling unit's control via PC through the home network or internet;
- › A three-level menu: user/service/adjuster;
- › User friendly, multilingual and up-to-date interface.

MB-Gateway enables ventilation units, based on control technology produced by Salda, to connect through TCP/IP to the wide range of control devices.

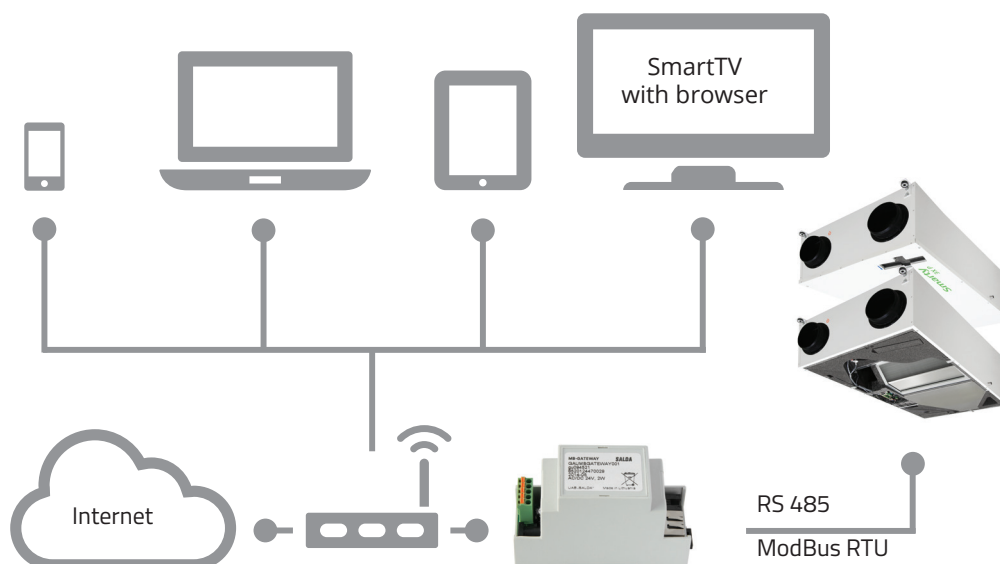

SaldaAir:



Google Play store



iTunes Apple store:

Suitable Air handling units based on controllers:

Smarty 3XP



RIS EKO 3.0



RIRS EKO 3.0



RIS EKO 3.0



CONTROL OPTIONS DEPEND ON CONTROL BOARD TYPE:

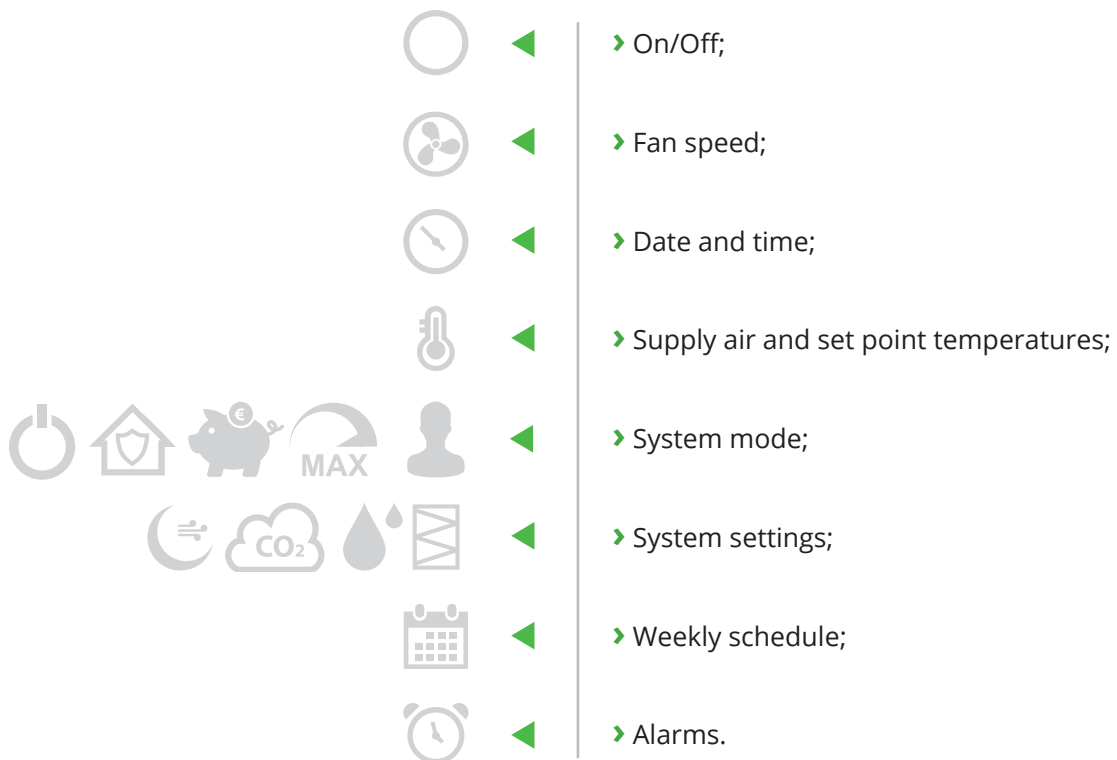

TECHNICAL FUNCTIONS:

- ▶ TCP/IP Modbus gateway;
- ▶ BACnet/IP gateway;
- ▶ IPv4 protocol;
- ▶ DHCP protocol;
- ▶ NetBIOS/hostname;
- ▶ WEB server;
- ▶ FTP server;
- ▶ Formation of Modbus commands/responses to HTTP queries;
- ▶ authorised login;
- ▶ automated data transmission between Modbus devices;
- ▶ data logger;
- ▶ dateTime synchronization;
- ▶ sending of AHU's warnings and alarms by email
- ▶ module software upgrading through the microSD memory card (the upgrade can also be written through the FTP client);
- ▶ RTC;
- ▶ galvanically insulated RS485 communications line.

DIMENSIONS:

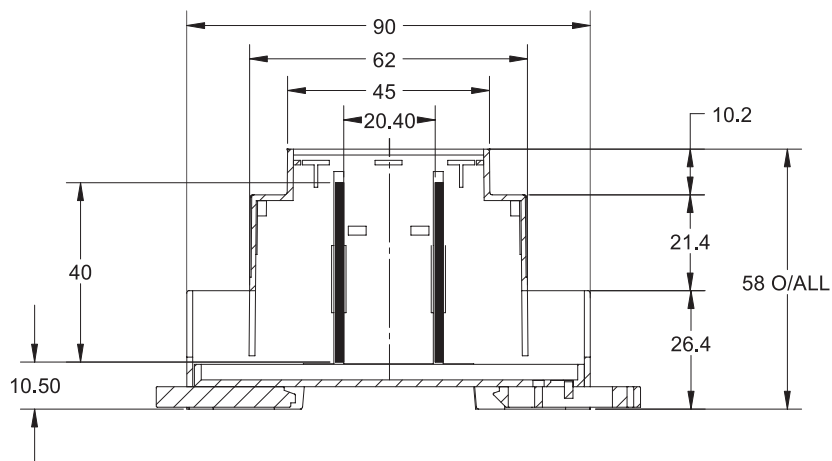

BASIC INSTALLATION DIAGRAM OF THE PRODUCT:



Scan code and go to MB Gateway



Scan code and download firmware

Distributor

More information? Find it there:

 Ragainės g. 100
LT-78109 Šiauliai, Lithuania

 +370 41 54 04 15
+370 41 54 04 17

 office@salda.lt
www.salda.lt