



# AMBERAIR COMPACT VEKA INT 400-4000 EKO

EN MOUNTING AND INSTALLATION INSTRUCTION



## 1. CONTENT

<b>2. SYMBOLS AND MARKING</b>	<b>3</b>
<b>3. SAFETY INSTRUCTIONS AND PRECAUTIONS</b>	<b>4</b>
<b>4. INFORMATION ABOUT THE PRODUCT</b>	<b>5</b>
4.1. DESCRIPTION	5
4.2. DIMENSIONS AND WEIGHT	5
4.3. TECHNICAL DATA	7
4.4. OPERATING CONDITIONS	9
4.5. STANDARD PACKAGE OF COMPONENTS	9
4.6. DESCRIPTION OF COMPONENTS	9
<b>5. INSTALLATION</b>	<b>10</b>
5.1. RECEPTION OF GOODS	10
5.2. TRANSPORTATION AND STORAGE	10
5.3. UNPACKING	10
5.4. PIPING AND INSTRUMENTATION DIAGRAM	11
5.5. MOUNTING	12
5.5.1. UNIT PLACING AND MOUNTING POSITIONING REQUIREMENTS	13
5.5.2. CEILING-MOUNTING OF THE UNIT	13
5.6. CONNECTION OF THE AIR DUCT	13
5.7. CONNECTION OF THE UNIT TO ELECTRIC NETWORK	14
5.8. START-UP RECOMMENDATIONS	14
5.8.1. SYSTEM PROTECTION	14
5.8.2. PRE-STARTUP RECOMMENDATIONS OF THE UNIT (IN THE PRESENCE OF THE END-USER)	14
<b>6. MAINTENANCE</b>	<b>15</b>
6.1. SAFETY INSTRUCTION	15
6.2. GENERAL RECOMMENDATIONS FOR VENTILATION SYSTEM MAINTENANCE	15
6.3. COVER OPENING	15
6.4. FILTERS MAINTENANCE	16
6.5. FANS MAINTENANCE	16
6.6. HEATER MAINTENANCE	17
6.7. CONTROL BOARD MAINTENANCE	17
6.8. AIR DAMPER MAINTENANCE	18
<b>7. CONTROL</b>	<b>19</b>
7.1. DEVICE CONTROL	19
7.2. DEVICE FUNCTIONS	19
<b>8. CONNECTION OF ACCESSORIES</b>	<b>20</b>
8.1. FIRE PROTECTION SIGNAL INPUT (FIRE PROTECTION INPUT (NC))	20
8.2. CONNECTION OF AIR DAMPERS	20
8.3. CONNECTION OF REMOTE CONTROL PANEL	21
8.4. WATER HEATER CIRCULATION PUMP AND VALVE ACTUATOR	21
8.5. EXTRACT AIR FAN	21
8.6. EXTRACT AIR FILTER PRESSURE SWITCH	22
8.7. RECOMMENDED SCHEME FOR CONNECTION OF INTERNAL AND EXTERNAL COMPONENTS	23
<b>9. POSSIBLE FAULTS AND TROUBLESHOOTING</b>	<b>35</b>
<b>10.ECODESIGN DATA TABLE</b>	<b>36</b>
<b>11.DECLARATION OF CONFORMITY</b>	<b>37</b>
<b>12.WARRANTY</b>	<b>38</b>
12.1. LIMITED WARRANTY COUPON	38

## 2. SYMBOLS AND MARKING



**Warning – pay attention**



**Additional information**

Apply the auxiliary label on the unit (on an easily accessible location) or on the dashed location of the technical manual in order to keep the important information about the unit.

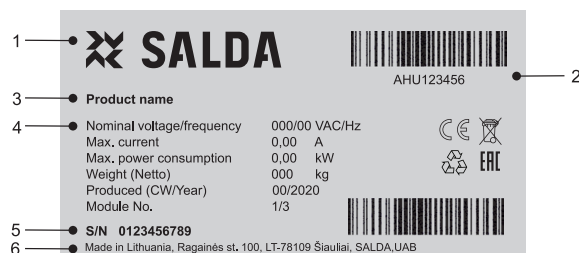

Figure 2.1. Technical label

1 - Logo; 2 - Product code (SKU); 3 - Product name; 4 - Technical data; 5 - Serial number; 6 - Production place.



Figure 2.2. Indication for duct connection (ODA - outdoor air; SUP - supply air).



Figure 2.3. Indication for water flow connection

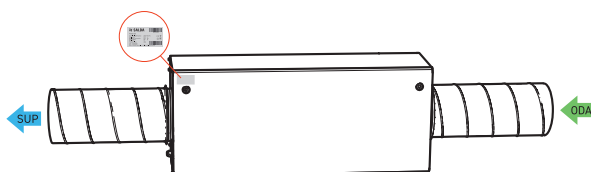

Figure 2.4. Technical label place and air duct indication AmberAir Compact VEKA INT 400-700 E EKO

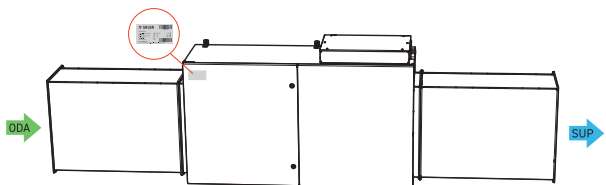

Figure 2.5. Technical label place and air duct indication AmberAir Compact VEKA INT 1000-4000 E EKO

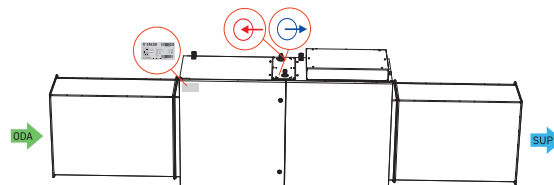

Figure 2.6. Technical label place and air duct indication AmberAir Compact VEKA INT 1000-4000 W EKO



**NOTE. Ducts are not the part of the unit.**

### 3. SAFETY INSTRUCTIONS AND PRECAUTIONS

Read these instructions very carefully before installing and using this equipment. Installation, connection and maintenance should be carried out by a qualified technician and in accordance with the local regulations and legislation.

The company shall take no responsibility for the injuries or damaged property if the safety requirements are not followed or the device is modified without the permission of the manufacturer.

#### Main safety rules

---

##### Danger



- Before carrying out any electrical or maintenance works, make sure that the device is disconnected from the mains and all moving parts of the device have stopped.
- Make sure that the fans are not accessible through air ducts or branch openings.
- If any liquids on electric parts or connections that bear voltage are noticed, stop the operation of the device.
- Do not plug the device into the mains that differ from the one indicated on the label or on the housing.
- Voltage of the mains should comply with the electro technical parameters indicated on the label.
- The device should be earthed in accordance with the regulations on the installation of electric devices. Turning on and using unearthed device is not allowed. Follow the requirements specified on the device's labels that indicate danger.

---

##### Warnings



- Connection of electricity and maintenance of the device should be performed by the qualified personnel only and in accordance with the manufacturer's instructions and safety requirements.
- In order to reduce the risk during installation and maintenance, suitable protective clothing must be worn.
- Beware of sharp angles while carrying out installation and maintenance works.
- Do not touch heating elements until they haven't cooled down.
- Some devices are heavy, you should be very careful while transporting and installing them. Use suitable lifting equipment.
- When connecting electricity to the mains, a circuit breaker of suitable size must be used.

---

##### Warning!



- If the device is installed in a cold environment, make sure that all connections and tubes are properly isolated. Intake and discharge air ducts should be isolated in all cases.
- Openings of the ducts should be covered during transportation and installation.
- Make sure not to damage the heater when connecting the piping of the water heater. For tightening up, use a wrench/spanner.

---

##### Before starting up the device



- make sure, that there are no strange objects inside;
- manually check fans to make sure they are not stuck or blocked;
- if rotary heat exchanger is installed in the device, make sure that it is not stuck or blocked;
- check the earthing;
- make sure that all components and accessories are connected in accordance with the wiring diagram or provided instructions.

---

##### Danger: Fumes



*Salda Antifrost* system uses dis-balancing of the air flow and it may cause negative pressure in premises. Great care should be taken when using at the same time in premises as another heating appliance what depend on the air in premises. Such appliances include gas, oil, wood or coal-fired boilers and heaters, fireplaces, continuous flow or other water heaters, gas hobs, cookers or ovens which draw air in from the room and duct exhaust gases out through a chimney or extraction ducting. The heating appliance can be starved of oxygen, impairing combustion. In exceptional cases harmful gases could be drawn out of the chimney or extraction ducting back into the room. In this case we strictly recommend to turn off *Salda Antifrost* and use an external preheater for heat exchanger anti-frost protection (see *Salda Antifrost* function on the Remote controller manual).

---



## 4. INFORMATION ABOUT THE PRODUCT

### 4.1. DESCRIPTION

Air supply units AmberAir Compact VEKA INT EKO designed for the air supply to commercial, warehousing, industrial kitchen, etc. premises where heat recovery is not required. The ventilation unit has a low height for the installation under the ceilings, alternatively, AmberAir Compact VEKA INT EKO can be installed on the wall or under the roof.

AmberAir Compact VEKA INT EKO has EC-type motor, heater (depends on model), filter, motorized air damper and control board.

AmberAir Compact VEKA INT EKO can be controlled by external remote panel (accessory).

 Not suitable for operation in pools, saunas and other similar premises.

### 4.2. DIMENSIONS AND WEIGHT

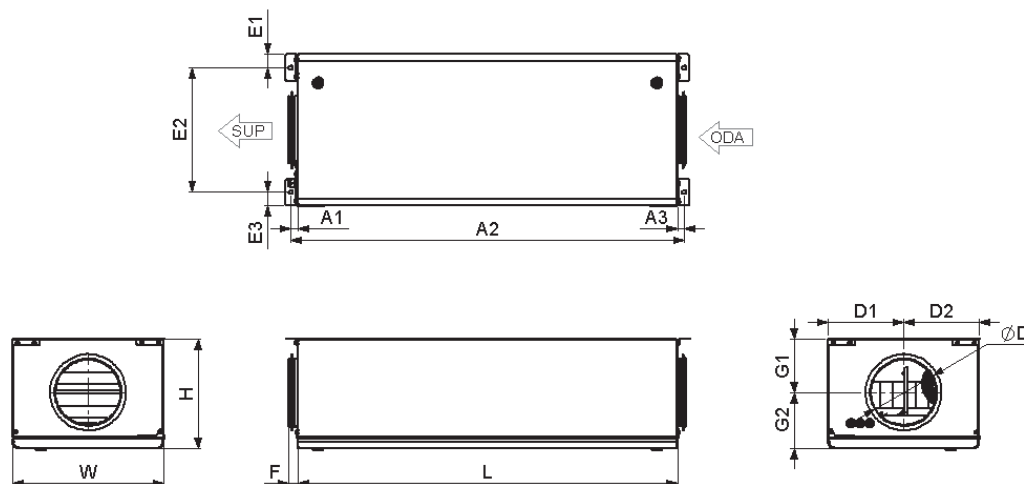

Figure 4.2.1. AmberAir Compact VEKA INT 400-700 EKO

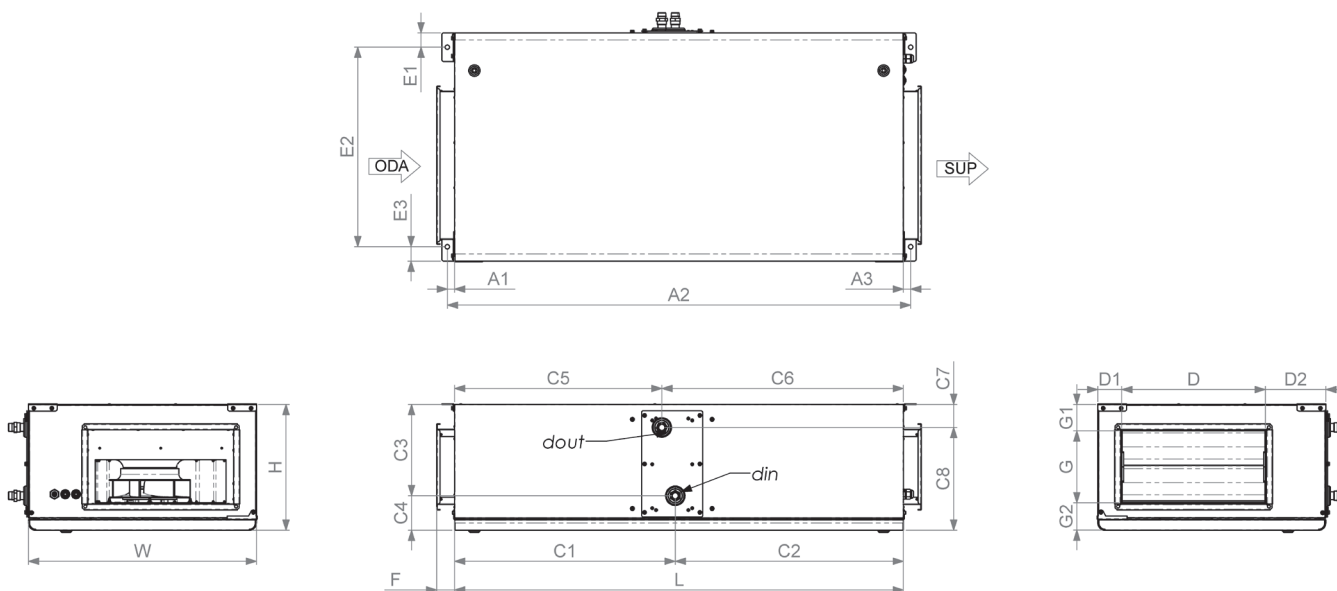

Figure 4.2.2. AmberAir Compact VEKA INT 1000-2000 EKO

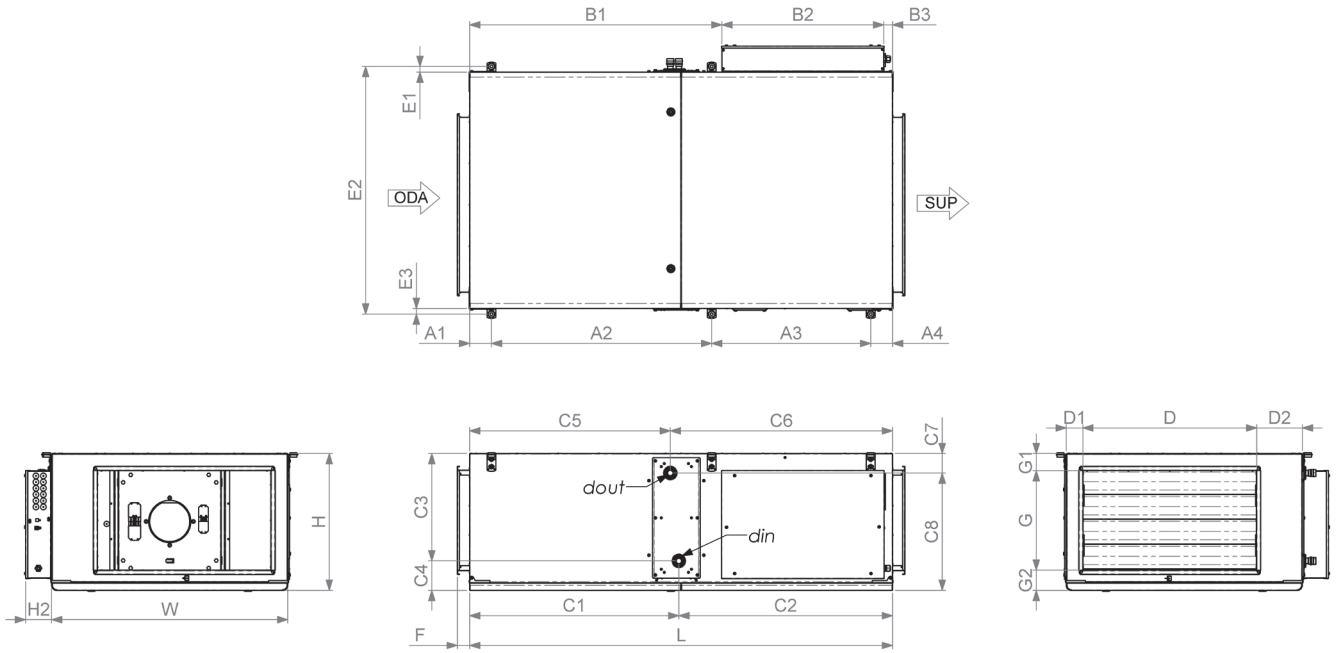

Figure 4.2.3. AmberAir Compact VEKA INT 3000-4000 EKO

AmberAir Compact VEKA INT EKO		400	700	1000	1000 W	2000	2000W	3000	3000 W	4000	4000 W
L	[mm]	1130	1200	1250		1550		1701			
W	[mm]	325	500	635		750		950			
H	[mm]	325	350			460		550			
ØD/D	[mm]	200	250	400		500		700			
G	[mm]	-		200		250		400			
F	[mm]	28	38	50							
H2	[mm]	-						105			
A1	[mm]	20				88					
A2	[mm]	1173	1240	1291		1591		886			
A3	[mm]	20				640					
A4	[mm]	-				88					
B1	[mm]	-				1015					
B2	[mm]	-				651					
B3	[mm]	-				35					
C1	[mm]	-		615	-	727	-	842	-	842	
C2	[mm]	-		635	-	823	-	859	-	859	
C3	[mm]	-		254	-	369	-	432	-	432	
C4	[mm]	-		96	-	91	-	118	-	118	
C5	[mm]	-		577	-	693	-	807	-	807	
C6	[mm]	-		673	-	857	-	894	-	894	
C7	[mm]	-		64	-	72	-	78	-	78	
C8	[mm]	-		286	-	388	-	472	-	472	
D1	[mm]	225	250	67							
D2	[mm]	225	250	168		182		183			
din		-			G1/2	-	G1/2	-	G3/4	-	G3/4
dout		-			G1/2	-	G1/2	-	G3/4	-	G3/4
E1	[mm]	40				23					
E2	[mm]	370	420	555		670		996			
E3	[mm]	40				23					
G1	[mm]	158	158	74		124		69			
G2	[mm]	168	193	76		86		81			

AmberAir Compact VEKA INT EKO	400-1.2 L1 SW2	400-2.0 L1 SW2	400-5.0 L1 SW2	700-2.4 L1 SW2	700-5.0 L1 SW2	700-9.0 L1 SW2
WEIGHT [kg]	33	36	37	41	42	44

AmberAir Compact VEKA INT EKO	1000-2.4 L1 SW2	1000-5.0 L1 SW2	1000-9.0 L1 SW2	1000-12.0 L1 SW2	1000-14.4 L1 W SW2	2000-6.0 L1 SW2	2000-15 L1 SW2
WEIGHT [kg]	52	57	57	55	57	84	87

AmberAir Compact VEKA INT EKO	2000-21 L1 SW2	2000 26.9 W SW2	3000-15 L1 SW2	3000-21 L1 SW2	3000-30 L1 SW2	3000-39 L1 SW2	3000-40.6 L1 W SW2
WEIGHT [kg]	89	86	135	140	141	143	132

AmberAir Compact VEKA INT EKO	4000-21 L1 SW2	4000-27 L1 SW2	4000-39 L1 SW2	4000-54 L1 SW2	4000-54 L1 W SW2
WEIGHT [kg]	137	138	144	149	130

### 4.3. TECHNICAL DATA

AMBERAIR COMPACT VEKA INT EKO	400-1.2 L1 SW2	400-2.0 L1 SW2	400-5.0 L1 SW2	700-2.4 L1 SW2	700-5.0 L1 SW2
<b>FAN</b>					
phase/voltage	[50 Hz/VAC]	~1/230	~1/230	~1/230	~1/230
power/current	[kW/A]	0,08/0,75	0,08/0,75	0,08/0,75	0,17/1,4
speed	[min <sup>-1</sup> ]	3200	3200	3200	3230
control input	[VDC]	0-10	0-10	0-10	0-10
protection class		IP54	IP54	IP54	IP54
Integrated electrical heater	[kW]	1,2	2,0	5,0	2,4
Total power/current consumption	[kW/A]	1,28/5,95	2,08/9,44	5,08/13,32	2,57/11,83
Automatic control integrated		EKO	EKO	EKO	EKO
Insulation of walls	[mm]	30	30	30	30
Air filter (class, dimensions LxWxH)	[mm]	FMK 381x259x150/5 ePM10 65%	FMK 381x259x150/5 ePM10 65%	FMK 381x259x150/5 ePM10 65%	FMK 431x284x170-7 ePM10-65-SE
Device protection class		IP34	IP34	IP34	IP34

AMBERAIR COMPACT VEKA INT EKO	700-9.0 L1 SW2	1000-2.4 L1 SW2	1000-5.0 L1 SW2	1000-9.0 L1 SW2	1000-12.0 L1 SW2
<b>FAN</b>					
phase/voltage	[50 Hz/VAC]	~1/230	~1/230	~1/230	~1/230
power/current	[kW/A]	0,17/1,4	0,17/1,4	0,17/1,4	0,17/1,4
speed	[min <sup>-1</sup> ]	3230	2860	2860	2860
control input	[VDC]	0-10	0-10	0-10	0-10
protection class		IP54	IP54	IP54	IP54
Integrated electrical heater	[kW]	9,0	2,4	5,0	9,0
Total power/current consumption	[kW/A]	9,17/14,40	2,57/11,83	0,05/13,9	0,09/14,41
Automatic control integrated		EKO	EKO	EKO	EKO
Insulation of walls	[mm]	30	30	30	30
Air filter (class, dimensions LxWxH)	[mm]	FMK 431x284x170-7 ePM10-65-SE	FMK 566x283x270/7 ePM10 65%	FMK 566x283x270/7 ePM10 65%	FMK 566x283x270/7 ePM10 65%
Device protection class		IP34	IP34	IP34	IP34

<b>AMBERAIR COMPACT VEKA INT EKO</b>		<b>1000-14.4 L1 W SW2</b>	<b>2000-6.0 L1 SW2</b>	<b>2000-15 L1 SW2</b>	<b>2000-21 L1 SW2</b>	<b>2000 26.9W SW2</b>
<b>FAN</b>						
phase/voltage	[50 Hz/VAC]	~1/230	~1/230	~1/230	~1/230	~1/230
power/current	[kW/A]	0,17/1,4	0,37/1,65	0,37/1,65	0,37/1,65	0,37/1,65
speed	[min <sup>-1</sup> ]	2860	2010	2010	2010	2010
control input	[VDC]	0-10	0-10	0-10	0-10	0-10
protection class		IP54	IP54	IP54	IP54	IP54
Integrated electrical heater	[kW]	-	6,0	15,0	21,0	-
Total power/current consumption	[kW/A]	0,17/1,4	6,37/16,65	15,37/23,30	21,37/31,96	0,37/1,65
Automatic control integrated		EKO	EKO	EKO	EKO	EKO
Insulation of walls	[mm]	30	30	30	30	30
Air filter (class, dimensions LxWxH)	[mm]	FMK 566x283x270/7 ePM10 65%	FMK 682x394x307/7 ePM10 65%	FMK 682x394x307/7 ePM10 65%	FMK 682x394x307/7 ePM10 65%	FMK 682x394x307/7 ePM10 65%
Device protection class		IP34	IP34	IP34	IP34	IP34

<b>AMBERAIR COMPACT VEKA INT EKO</b>		<b>3000-15 L1 SW2</b>	<b>3000-21 L1 SW2</b>	<b>3000-30 L1 SW2</b>	<b>3000-39 L1 SW2</b>	<b>3000-40.6 L1 W SW2</b>
<b>FAN</b>						
phase/voltage	[50 Hz/VAC]	~1/230	~1/230	~1/230	~1/230	~1/230
power/current	[kW/A]	0,87/4,5	0,87/4,5	0,87/4,5	0,87/4,5	0,87/4,5
speed	[min <sup>-1</sup> ]	2200	2200	2200	2200	2200
control input	[VDC]	0-10	0-10	0-10	0-10	0-10
protection class		IP54	IP54	IP54	IP54	IP54
Integrated electrical heater	[kW]	15,0	21,0	30,0	39,0	-
Total power/current consumption	[kW/A]	15,87/26,10	21,87/35,50	30,87/47,50	39,87/60,50	0,87/4,5
Automatic control integrated		EKO	EKO	EKO	EKO	EKO
Insulation of walls	[mm]	30	30	30	30	30
Air filter (class, dimensions LxWxH)	[mm]	FMK 822x485x340/8 ePM10 65%	FMK 822x485x340/8 ePM10 65%	FMK 822x485x340/8 ePM10 65%	FMK 822x485x340/8 ePM10 65%	FMK 822x485x340/8 ePM10 65%
Device protection class		IP34	IP34	IP34	IP34	IP34

<b>AMBERAIR COMPACT VEKA INT EKO</b>		<b>4000-21 L1 SW2</b>	<b>4000-27 L1 SW2</b>	<b>4000-39 L1 SW2</b>	<b>4000-54 L1 SW2</b>	<b>4000-54 L1 W SW2</b>
<b>FAN</b>						
phase/voltage	[50 Hz/VAC]	~1/230	~1/230	~1/230	~1/230	~1/230
power/current	[kW/A]	1,3/6,4	1,3/6,4	1,3/6,4	1,3/6,4	1,3/6,4
speed	[min <sup>-1</sup> ]	2390	2390	2390	2390	2390
control input	[VDC]	0-10	0-10	0-10	0-10	0-10
protection class		IP54	IP54	IP54	IP54	IP54
Integrated electrical heater	[kW]	21	27	39	54	-
Total power/current consumption	[kW/A]	22,3/36,75	28,3/45,41	40,3/62,76	55,3/84,4	1,30/6,40
Automatic control integrated		EKO	EKO	EKO	EKO	EKO
Insulation of walls	[mm]	30	30	30	30	30
Air filter (class, dimensions LxWxH)	[mm]	FMK 822x485x340/8 ePM10 65%	FMK 822x485x340/8 ePM10 65%	FMK 822x485x340/8 ePM10 65%	FMK 822x485x340/8 ePM10 65%	FMK 822x485x340/8 ePM10 65%
Device protection class		IP34	IP34	IP34	IP34	IP34

Acoustic data: check the product page on [www.salda.it](http://www.salda.it)



**Not suitable for installation in living rooms: additional noise insulation required.**

#### 4.4. OPERATING CONDITIONS

AMBERAIR COMPACT VEKA INT EKO	400-700	1000-4000
Outdoor air temp. without frost protection	-23 .. 40 °C	-
Ambient air temp.	0 .. 40 °C	-25 .. 40 °C
Max. ambient air humidity	80 %	-
Operation environment	Indoors	Indoors

#### 4.5. STANDARD PACKAGE OF COMPONENTS

AMBERAIR COMPACT VEKA INT EKO	400-2000	3000-4000
Washers 5 DIN 440R	-	12
ANTI VIBRATION PAD 313508000	-	6
KEY 291103	1	1
SUSPENSION BRACKET	-	6
BOLT M5X20	-	12

#### 4.6. DESCRIPTION OF COMPONENTS

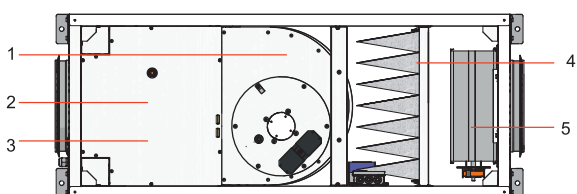

Figure 4.6.1. AmberAir Compact VEKA INT EKO 400/700

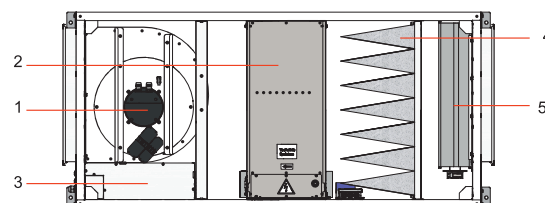

Figure 4.6.2. AmberAir Compact VEKA INT EKO 1000/2000

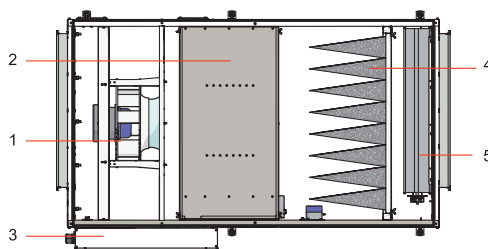

Figure 4.6.3. AmberAir Compact VEKA INT EKO 3000/4000

1 - Supply fan; 2 - Electrical/water heater/pre-heater; 3 - Control board; 4 - Supply air filter (pocket); 5 - supply air damper.

## 5. INSTALLATION

### 5.1. RECEPTION OF GOODS

Each device is carefully checked before transportation. When receiving the goods, checking the devices for any damage made during transportation is recommended. If any damage to the unit is observed, immediately contact the representatives of a transport company. Please inform the representative of the manufacturer, if any deviation of the device is noticed.

### 5.2. TRANSPORTATION AND STORAGE

- All units are factory-packaged to withstand normal conditions of transportation.
- When unpacking, check the unit for any damage made during transportation. Installing of damaged units is not allowed!
- The packaging is used for protection purpose only!
- When unloading and storing the units, use suitable lifting equipment to avoid damage and injuries. Do not lift units by holding on power supply cables, connection boxes, air extract or exhaust flanges. Avoid hits and shock overloads. Before installation, the units must be stored in a dry room with the relative air humidity not exceeding 70% (at +20°C) and with an average ambient temperature ranging between +5 °C and +30 °C. The storage place must be protected against dirt and water.
- The units must be transported to the storage place or installation site using forklifts.
- The recommended storage period should not be longer than one year. In case of storing the units for a period longer than one year, checking if the fan bearings and motor rotate without difficulty (turning the impeller by hand) and if the electric circuit insulation is not damaged or the moisture has not accumulated must be performed before the installation of the unit.

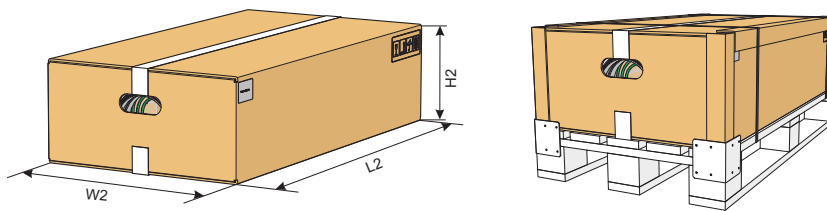

AMBERAIR COMPACT VEKA INT EKO	H2	W2	L2	MAX. NUMBER OF TRANSPORTED PACKAGES
	[mm]	[mm]	[mm]	[pcs.]
400	480	500	1250	1
700	500	550	1325	1
1000 E	630	705	1460	1
1000 W	630	745	1460	1
2000 E	740	815	1760	1
2000 W	740	854	1760	1
3000	830	1130	1870	1
4000	830	1130	1870	1

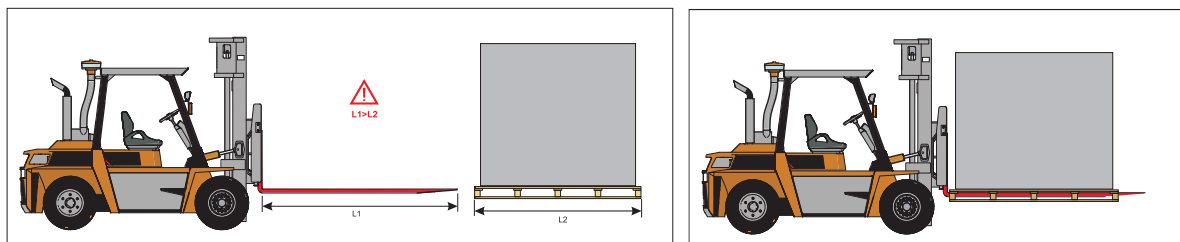

Figure 5.2.1. Lifting by forklift.



In order to prevent damage to the casing, only a product placed on a pallet should be lifted.

### 5.3. UNPACKING



Accessories may be packed together with the product. Prior to transporting the unit, the accessories should be unpacked first.

- Remove the film from the unit.
- Remove the bracing packaging tape that keeps the protective profiles in place.
- Remove the protective profiles.
- After unpacking the unit, examine it to make sure that no damage was made during transportation. Installing of damaged units is not allowed!

- Before commencing the installation of the unit, please check if all ordered equipment have been delivered. Any variation from the ordered equipment list must be reported to the product supplier.

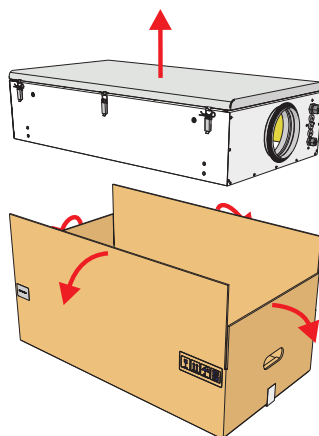

### 5.4. PIPING AND INSTRUMENTATION DIAGRAM

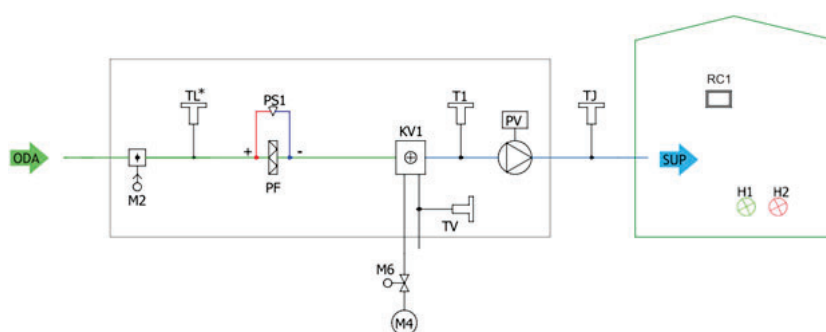

Figure 5.4.1. AmberAir Compact VEKA INT W EKO (\* For AmberAir Compact VEKA 1000-2000 units TL is outside of the unit on the left side of M2)

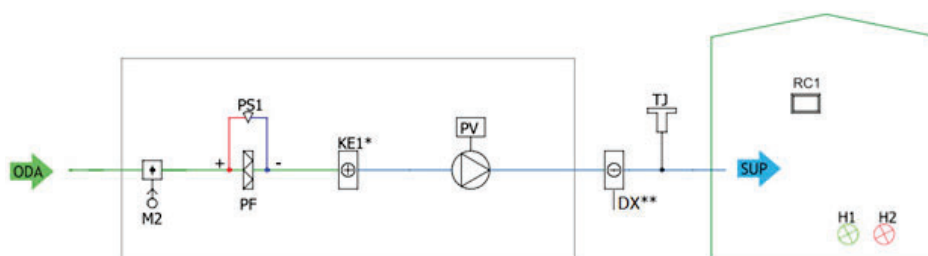



Figure 5.4.2. AmberAir Compact VEKA INT E EKO (\* For AmberAir Compact VEKA 400-700 units KE1 is on the right side of PV; \*\* Possible to control)

#### LIST OF COMPONENTS

<b>PV</b>	Supply air fan	<b>TL</b>	Outdoor air temperature sensor
<b>KE1</b>	Electric heater	<b>TJ</b>	Supply air temperature sensor
<b>PF</b>	Supply air filter	<b>PS1</b>	Supply air filter differential pressure sensor
<b>M2</b>	Outdoor air damper actuator	<b>M4/M</b>	Water heater circular pump
<b>KV1</b>	Water heater	<b>RC1</b>	Stouch or Flex remote control panel
<b>M6/SV1</b>	Water heater valve actuator	<b>TV</b>	Water heater temperature sensor
	Ventilated premises	<b>T1</b>	Water heater thermostat
<b>DX</b>	DX cooler		

#### POSSIBLE PCB INPUTS/OUTPUTS

<b>EAS</b>	External alarm	<b>H2</b>	Alarm indication output
<b>H1</b>	Working indication output		
	Fans speed switch (BOOST)		System mode switch (START/STOP)

## 5.5. MOUNTING

- Installation should be carried out by qualified and trained staff only.
- When connecting air ducts, consider the labels on the casing of the unit.
- Before connecting to the air duct system, the connection openings of ventilation unit should be closed.
- When connecting the ducts, the air-flow direction indicated on the device housing should be observed.
- Do not connect the bends close to connection flanges of the unit. The minimum distance of the straight air duct between the unit and the first branch of the air duct in the supply air duct must be  $1xD$ , in air exhaust duct  $3xD$ , where  $D$  is the diameter of the air duct.
- It is recommended to use the brackets (accessories). This will reduce the vibration transmitted by the unit to the air duct system and environment.
- Sufficient space must be provided for opening of the manhole and filter covers.
- If the ventilation unit is wall-mounted wall, it may transmit noise vibrations to the premises. Though the level of noise generated by the fans is admissible, mounting the unit at the distance of 400 mm from the nearest wall is recommended. Where this is not possible, mounting of the unit on the wall of the room where the level of noise is not significant is recommended.
- Ducts are connected to the unit in such way that they could be easily disassembled and the heater could be removed from the unit when carrying out maintenance, servicing and/or repairs



The protective film is used to protect the unit during transportation. It is recommended to remove the film; otherwise, oxidation signs may occur.

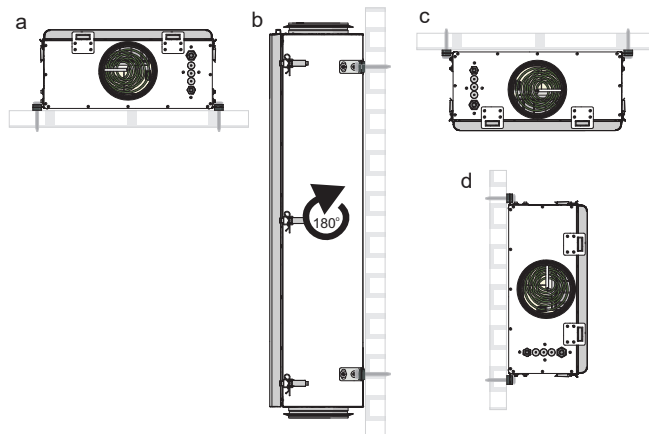

Figure 5.5.1. Mounting positions (d - mounting position not possible for units with pocket filters; b, d - mounting position not possible for water version)

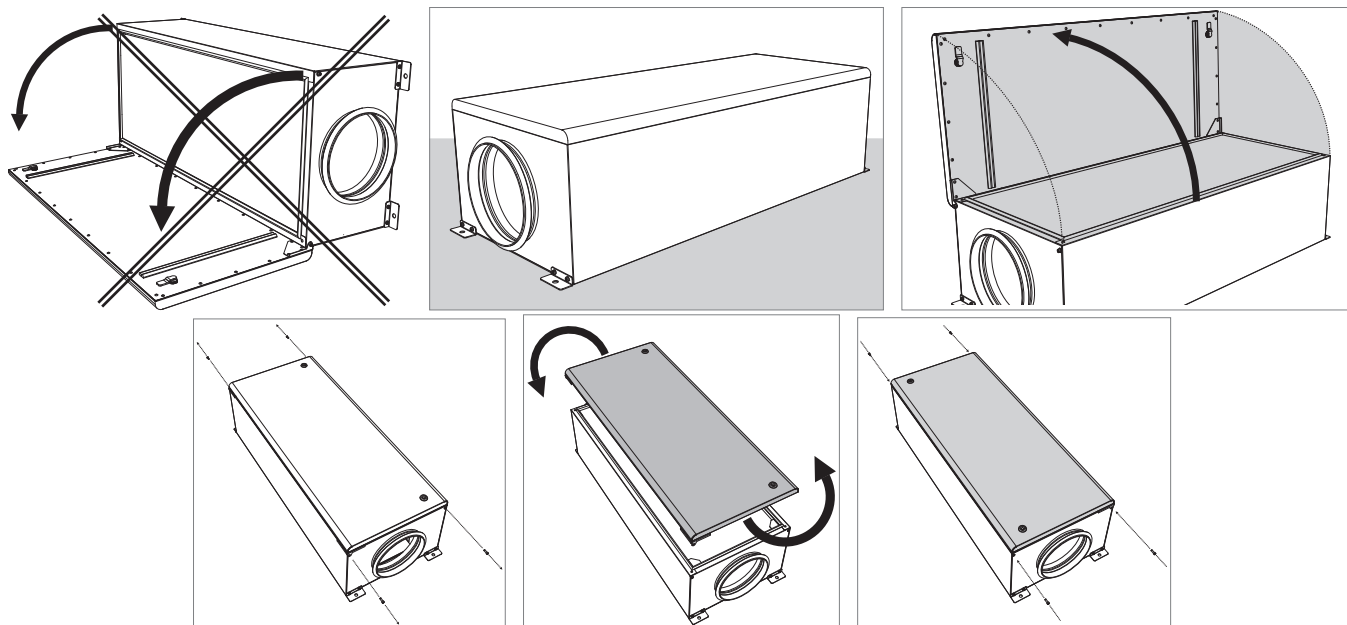

Figure 5.5.2. AmberAir Compact VEKA INT 400-700 EKO maintenance side change



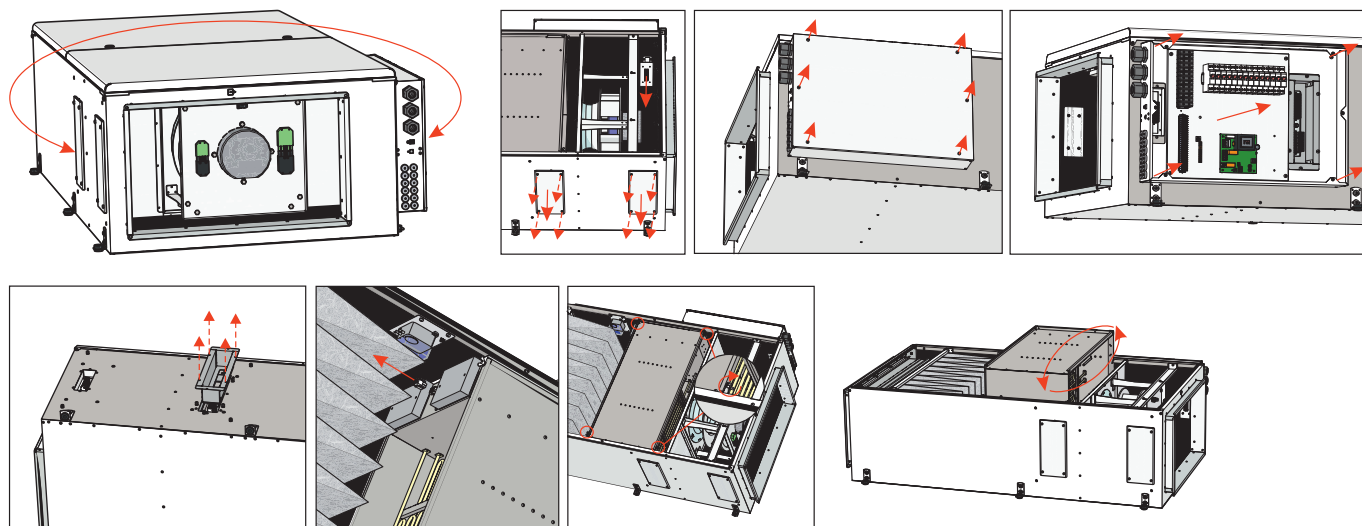
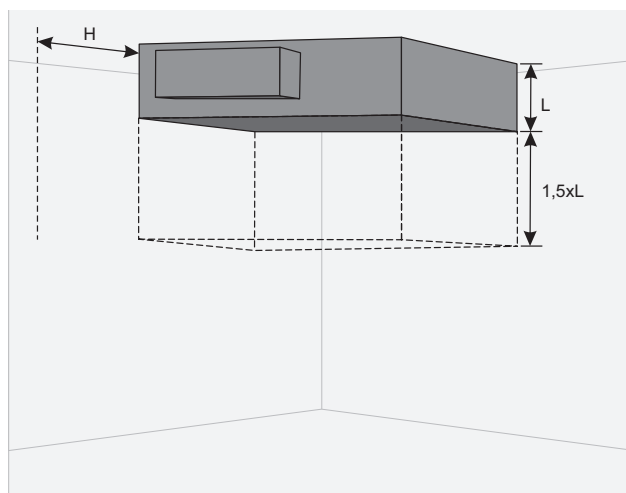

Figure 5.5.3. AmberAir Compact VEKA INT 1000-4000 EKO maintenance side change

### 5.5.1. UNIT PLACING AND MOUNTING POSITIONING REQUIREMENTS



Min. distance to open the door -  $1,5xL$ ; Min. distance to open the control box door -  $H > 400$  mm.

### 5.5.2. CEILING-MOUNTING OF THE UNIT

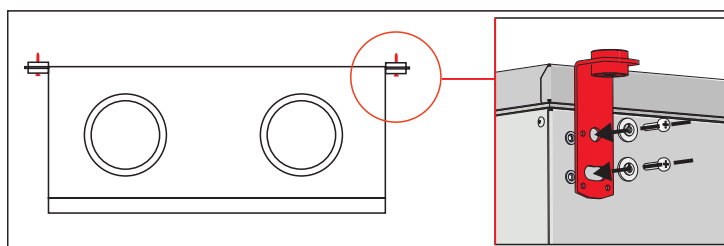

### 5.6. CONNECTION OF THE AIR DUCT

- The connected air ducts must not be bent and have separate fixing.
- Make sure that the fans can not be accessed through air duct heads. Otherwise, protective grid should be installed. You may choose the grid from the range of products provided in our website.
- Do not reduce the diameter of the piping near air inlet or exhaust ducts. If you want to reduce the airflow speed in the system, drop of pressure and noise level, you can increase the diameter.
- In order to reduce the level of the noise in the air supply system, install dampers (see the chapter on air supply system installation).
- In order to reduce air loss in the system, the air ducts and profile components should be of class C and higher. The catalogue on the above-mentioned items can be found in our website.
- External air and exhaust system piping should be isolated in order to prevent heat loss and condensation.
- Maintaining the distance of up to 8 meters between air intake and air exhaust ducts is recommended. Air supplying system should be installed away from potential air pollution sources.
- When installing air ducts next to the ventilation equipment, brackets must be used. They suppress vibration and assure secure installation of the various system parts. The necessary brackets can be found in our catalogue or website.

- Air ducts are often mistakenly connected in inappropriate location. The ventilation units bear the labels indicating the correct air duct connection layout. Before starting up the system, carefully check if all related works have been performed properly.



For flange diameters see chapter **"DIMENSIONS AND WEIGHT"**.

## 5.7. CONNECTION OF THE UNIT TO ELECTRIC NETWORK

- Supply voltage to the unit must be connected by a qualified specialist following the manufacturer's instructions and applicable safety guidelines.
- The unit's power network voltage must correspond to electro technical specifications of the unit indicated in the technical decal.
- The unit's voltage, power and other technical specifications are provided in the unit's technical decal (on the unit casing). The unit must be connected to the voltage plug socket of the grounded power network in accordance with the applicable requirements.
- The unit must be earthed according to electrical equipment installation regulation.
- Using extension wires (cables) and power network plug socket distribution devices is not allowed.
- Prior to carrying out any ventilation unit installation and connection works (before the unit is commissioned), the unit must be disconnected from the power network.
- After installation of the ventilation unit, the power network plug socket must be accessible at any time. If the unit is equipped with circuit breaker, disconnection from the power network is performed through the two-pole or four-pole circuit breaker (by disconnecting phase poles and neutral).
- Before it is connected to the power network, the unit must be carefully checked for any damage (execution, control, and measurement nodes) made during transportation.
- The power cable can be replaced only by a qualified technician, having evaluated the rated power and current.



The manufacturer does not assume any liability for personal injuries and property damage due to non-conformance with the provided instructions.

## 5.8. START-UP RECOMMENDATIONS

### 5.8.1. SYSTEM PROTECTION

Units with integrated control board have integrated protection devices against short circuit. AmberAir Compact VEKA INT EKO 400-2000 units have controller with F2 protection fuse of 250mA, 315mA or 350mA value. AmberAir Compact VEKA INT EKO 3000-4000 units control board is equipped with additional protection devices:

AmberAir Compact VEKA INT EKO	3000-15;21;30;39; 4000-21;27;39;54;	3000-40.6 W; 4000-54 W
Q2 (F1)	B25	6,3A
Q3 (F2)	B16	1A
Q4 (F3)	B25	6,3A
Q5	B32	-
Q6	C10	-
Q7	C10	-

It is recommended to use protection device on units that are unequipped with internal power supply protection devices.

AmberAir Compact VEKA INT EKO	400-1.2 L1 SW2	400-2.0 L1 SW2	400-5.0 L1 SW2	700-2.4 L1 SW2	700-5.0 L1 SW2	700-9.0 L1 SW2	1000-2.4 L1 SW2	1000-5.0 L1 SW2	1000-9.0 L1 SW2
Protection value	10 A	16 A	16 A	16 A	20 A	20 A	16 A	20 A	20 A

AmberAir Compact VEKA INT EKO	1000-12.0 L1 SW2	1000-14.4 L1 W SW2	2000-6.0 L1 SW2	2000-15 L1 SW2	2000-21 L1 SW2	2000 26.9W SW2	3000-40.6 L1 W SW2	4000-54 L1 W SW2
Protection value	25 A	3 A	20 A	32 A	40 A	4 A	6 A	10 A

If additional accessories are used, external protection device value can be different.



To ensure safe maintenance of the unit, it is necessary to turn off main switch and/or external protection device.

### 5.8.2. PRE-STARTUP RECOMMENDATIONS OF THE UNIT (IN THE PRESENCE OF THE END-USER)

Prior to start-up, the system must be carefully cleaned. Check for the following:

- operation systems and unit elements as well as automation and automation devices were not damaged during installation,
- all electrical devices are connected to power supply and fit for service,
- all necessary automation elements are installed and connected to power supply and terminal blocks,
- cable connection to terminal blocks comply with the existing wiring diagrams,
- all electrical equipment protection components are properly connected (if they are additionally used),
- cables and wires correspond to all applicable safety and functional requirements, diameters, etc.,
- earthing and protection systems are properly installed,
- condition of all seals and sealing surfaces is proper.

## 6. MAINTENANCE

### 6.1. SAFETY INSTRUCTION



Unplug the unit from the mains before opening the door (disconnect the power plug from the outlet or in case an automatic circuit breaker installed, disconnect it as well. Make sure that it cannot be turned on by third parties) and wait until the fans completely stop (for about 2 min.).

### 6.2. GENERAL RECOMMENDATIONS FOR VENTILATION SYSTEM MAINTENANCE

In order to ensure proper functioning of the system, maintenance requirements and its periods should be observed. Otherwise, the warranty shall be void. Some recommendations are provided in the table below, but they are just advisory, as the need for system maintenance depends on the location of the unit installation, the pollution of atmosphere, population, working hours, etc.

COMPONENT	DURING START-UP	AT LEAST EVERY 6 MONTHS
Filters	Check the cleanliness of the filters	Replace filters every 3 to 4 months or according to the control device indications.
Fans	Check the connections and the direction of rotation	Check cleanliness. Clean, if necessary
		Make sure that the impellers are not unbalanced.
		Make sure that the impellers do not cause noise when rotated by hand.
		Make sure that the fastening screws are not loose and free of mechanical damage.
	Check electrical connections and make sure that these are secured properly and are free of signs of corrosion.	
Control panel	Check the connections	Check the connections
Electric heater	Check the connections	Clean off dust, and check the electrical components and connections of the heater
Pressure sensor	Check electrical connections	Check the operation
Temperature sensor	Check electrical connections	Check the operation
Air supply and extract system	Check the connections	Clean
Air duct system	Check the tightness	Clean
Dampers, diffusers, grid	Check the tightness of connections	Clean
Switching unit (contactor)		Every 3 to 4 months, visually assess the functioning of the switching unit (contactor), i.e. make sure that its casing has no signs of melting or is not thermally damaged otherwise and does not produce any unusual sounds. All the contactors in the product or in its accessories must be checked.

### 6.3. COVER OPENING

Before opening the covers, first, unplug the unit from the mains, then wait for 2 minutes (until the fans completely stop).

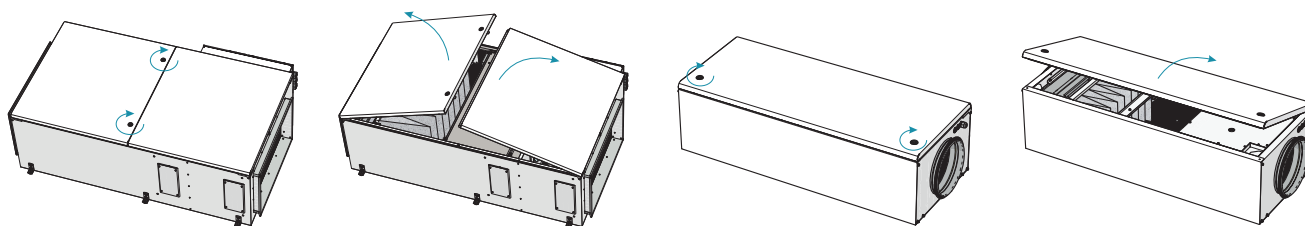

Figure 6.3.1. AmberAir Compact VEKA INT EKO

## 6.4. FILTERS MAINTENANCE

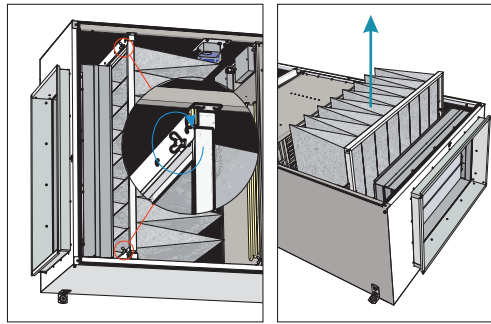

Figure 6.4.1. AmberAir Compact VEKA INT EKO

In order to remove the filters, open unit door and take off the filters.

Dirt increases air resistance in the filter, therefore, lower amount of air is supplied into the premises. Arrows on the filters must comply with airflow direction.



**After changing the filters, please reload the filter timer (if used). The instruction on reloading can be found in the control panel operation manual or on our website [www.salda.it](http://www.salda.it). Operation of the unit without filters is not allowed.**



**Change the filters every 3-4 months or according to the notification on the control device.**

## 6.5. FANS MAINTENANCE

- Fan maintenance should be performed by experienced and trained staff only.
- The fan should be inspected and cleaned at least once per year.
- Prior to commencing any maintenance or repairs, make sure the fan is disconnected from the power source.
- Proceed to maintenance and repair after any fan rotation is stopped.
- Observe staff safety regulations during maintenance and repairs.
- The motor features a heavy-duty ball bearing design. The motor is completely sealed and grease-free.
- Detach the fan from the unit.
- The impeller should be particularly checked for built-up material or debris that may cause an imbalance. Excessive imbalance may lead to accelerated wear on motor bearings and vibration.
- Clean impeller and inside housing with mild detergent, water and damp, soft cloth.
- Do not use high-pressure cleaner, abrasives, sharp tools or caustic solvents that may scratch or damage the housing and impeller.
- Do not plunge the motor into any fluid while cleaning the impeller. Make sure the impeller's balance weights are not moved.
- Make sure the impeller is free of any obstacles.
- Install the fan back into the unit. Connect fan power and control signals.
- In case the fan after maintenance does not automatically start up or stop, contact the manufacturer. Malfunction of the fan can be identified by the pressure in the system (when pressure switches are connected). In case of any fault in the fan motor, a notice will appear on the control panel.



**Prior to commencing any maintenance or repairs, make sure the unit is disconnected from the power source.**

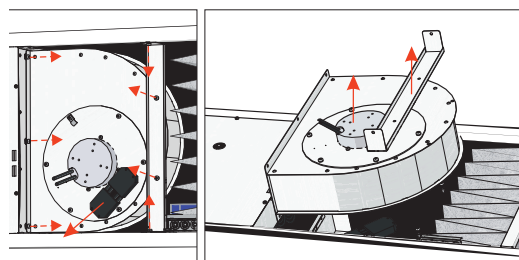

Figure 6.5.1. AmberAir Compact VEKA INT 400-700 EKO

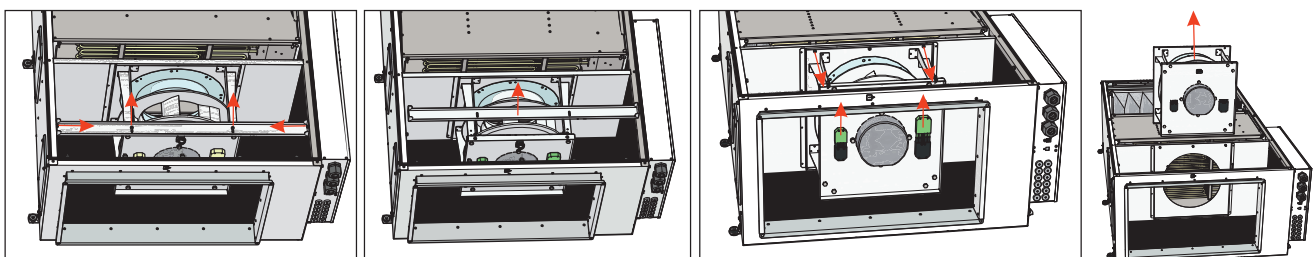

Figure 6.5.2. AmberAir Compact VEKA INT 1000-4000 EKO

## 6.6. HEATER MAINTENANCE

### ELECTRICAL HEATER:

- In case manual protection is activated, check for a fault before pressing the RESET button. If the fault is identified after it has been rectified, press the RESET button using a screwdriver or a similar object.
- Electrical heater does not require additional servicing. The filters must be replaced as described above.
- Heaters are equipped with 2 thermal protection devices: an automatic self-resetting protection device that is activated at +50 °C, and a manually restored protection device that is activated at +100 °C.
- After an activation of the manually restored protection device, make sure the unit is disconnected from the power supply. Wait until all heating elements cool down and the fans completely stop. Having identified and rectified the failure, to start the unit, press the RESET button. The failure can be identified by a qualified technician only.
- For AmberAir Compact VEKA INT 400-700 EKO units remove control board cover, disconnect the electrical heater connector and remove the heater. For AmberAir Compact VEKA INT 1000-4000 EKO units disconnect the electrical heater connector and remove the heater.

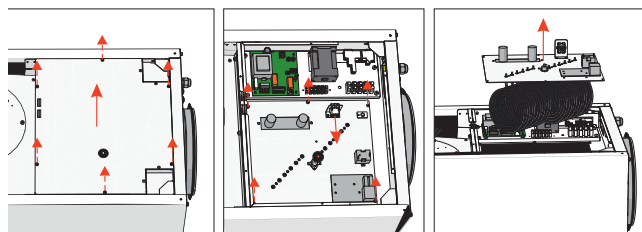

Figure 6.6.1. AmberAir Compact VEKA INT 400-700 E EKO

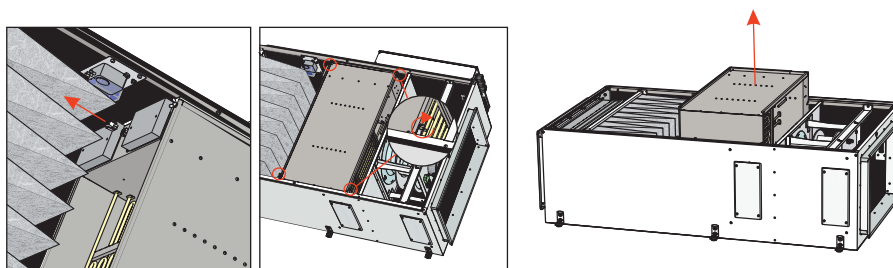

Figure 6.6.2. AmberAir Compact VEKA INT 1000-4000 E EKO

### WATER HEATER:

- Disconnect product unit from electric power source.
- Open the doors of the product.
- Drain the heating liquid from the system.
- Disconnect the heater from the system.
- Detach water thermostat sensor from the water heater.
- Unattach water heater temperature sensor from water heater.
- Remove 2 screws and remove the heater.

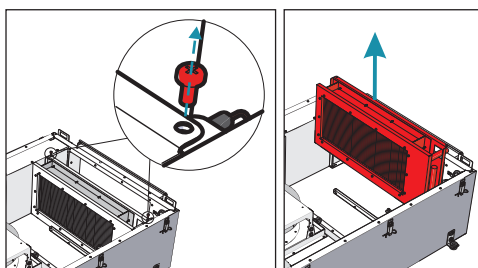

Figure 6.6.3. AmberAir Compact VEKA INT W EKO

## 6.7. CONTROL BOARD MAINTENANCE

- Disconnect product unit from electric power source.
- Open unit cover (except AmberAir Compact VEKA INT EKO 3000-4000 units).
- Unscrew the bolts of the control box cover.
- Remove the control box cover.
- Disconnect all necessary cables, wires, and connectors from control board.
- Unscrew the control board mounting bolts and remove control board.
- To reassemble, follow all maintenance steps in reverse order. When re-connecting cables, wires, and connectors, make sure to match each wire and connector to corresponding connection terminal and connector.

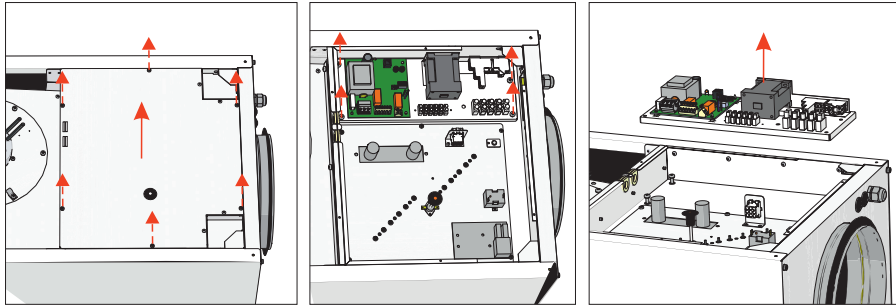

Figure 6.7.1. AmberAir Compact VEKA INT 400-700 EKO

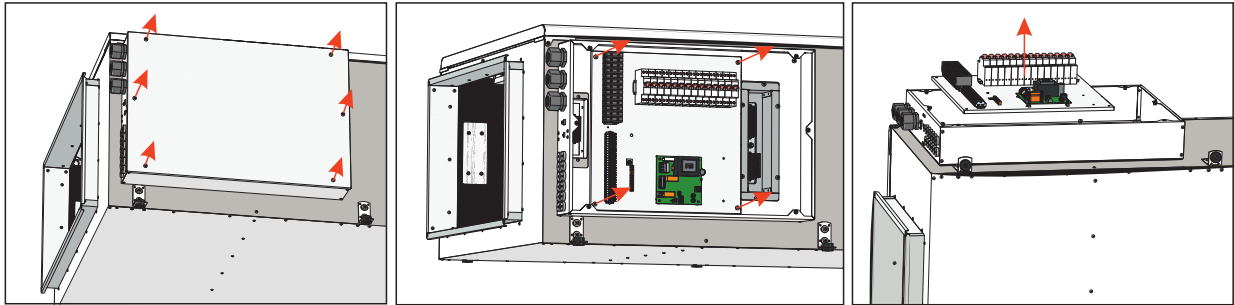

Figure 6.7.2. AmberAir Compact VEKA INT 1000-4000 EKO

## 6.8. AIR DAMPER MAINTENANCE

- Disconnect product unit from electric power source.
- Open the doors of the product.
- Detach air damper cable from the unit.
- Disconnect damper actuator.
- Remove the screws holding air damper.
- Remove air damper by sliding it upward.

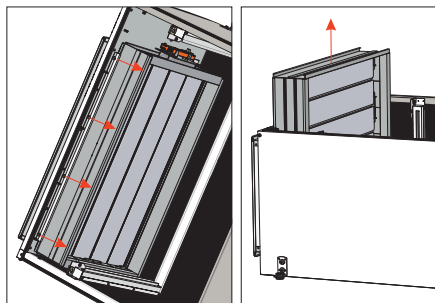

Figure 6.8.1. AmberAir Compact VEKA INT EKO

## 7. CONTROL

### 7.1. DEVICE CONTROL

Ventilation unit equipped with EKO control board can be controlled with FLEX or Stouch remote controller.

### 7.2. DEVICE FUNCTIONS

EKO control board operation functions and control of the device depends on the following:

1. Selected control interface (remote control panel). The selected interface affects access to the information and settings, however, it does not affect the logic of control. Full access to the information and settings is available on FLEX.
2. Unit configuration (internal/external components, sensors and control board settings or controller type).



**Refer to the instruction manual of the existing control device for unit control instructions.**

---



## 8. CONNECTION OF ACCESSORIES

### 8.1. FIRE PROTECTION SIGNAL INPUT (FIRE PROTECTION INPUT (NC))

Fire protection signal input must be normally closed for AmberAir Compact VEKA INT EKO, until the fire protection system is not connected a jumper is installed in the factory.

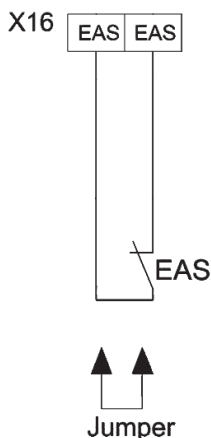

Figure 8.1.1. AmberAir Compact VEKA INT EKO 400-2000

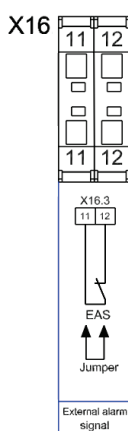

Figure 8.1.2. AmberAir Compact VEKA INT EKO 3000-4000 with electrical heater

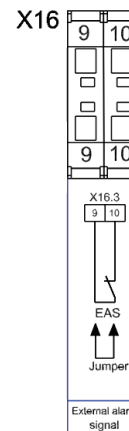

Figure 8.1.3. AmberAir Compact VEKA INT EKO 3000-4000 with water heater

### 8.2. CONNECTION OF AIR DAMPERS

AmberAir Compact VEKA INT EKO products have integrated supply air dampers. AmberAir Compact VEKA INT EKO 2000-4000 units additionally can control external extract air damper by Open/Close actuators.

#### Wiring diagram for AmberAir Compact VEKA INT EKO 2000-4000

M3 - Open/Close damper actuator. Upon activation of control output, the damper opens, upon deactivation of control output, the damper closes.

Control output:

AmberAir Compact VEKA INT EKO 2000 - X16:3;

AmberAir Compact VEKA INT EKO 3000-4000 E - X16:26;

AmberAir Compact VEKA INT EKO 3000-4000 W - X16:24

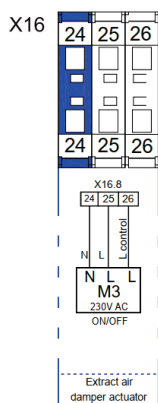

Figure 8.2.1. AmberAir Compact VEKA INT EKO 3000-4000 E

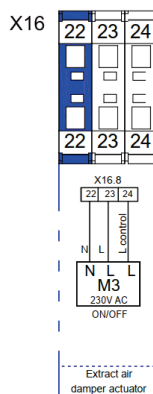

Figure 8.2.2. AmberAir Compact VEKA INT EKO 3000-4000 W

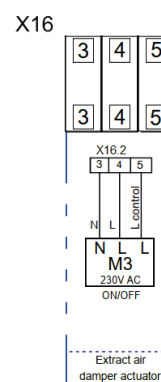
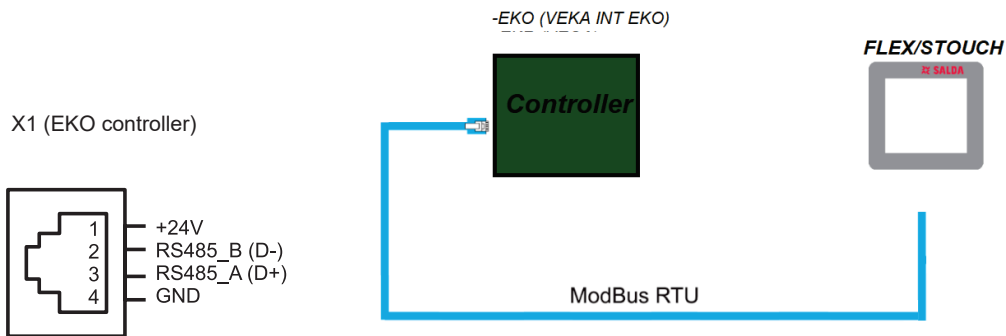

Figure 8.2.3. AmberAir Compact VEKA INT EKO 2000



### 8.3. CONNECTION OF REMOTE CONTROL PANEL



### 8.4. WATER HEATER CIRCULATION PUMP AND VALVE ACTUATOR

Water heater circulation pump and valve actuator can only be connected to the units that are designed to operate with water heater.

#### Wiring diagram

Valve actuator is controlled by 0-10 VDC signal. Circulation pump is controlled by On/Off signal.

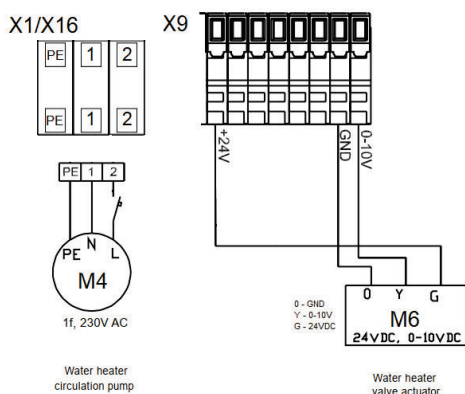

Figure 8.4.1. AmberAir Compact VEKA INT EKO 1000-2000 W

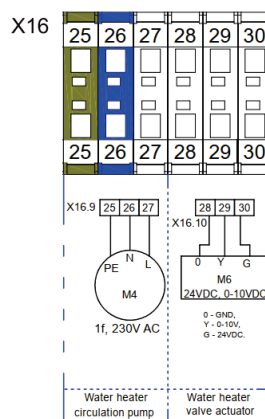

Figure 8.4.2. AmberAir Compact VEKA INT EKO 3000-4000 W

### 8.5. EXTRACT AIR FAN

AmberAir Compact VEKA INT EKO units are able to control external extract air fan. Fan should be 230VAC, EC type with 0-10VDC control.

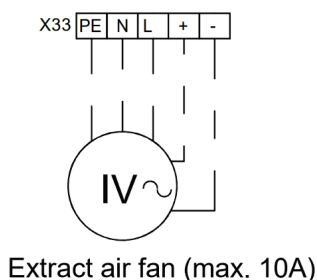

Figure 8.5.1. AmberAir Compact VEKA INT EKO 400-1000

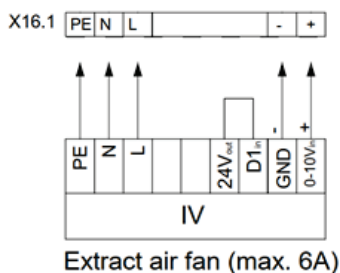

Figure 8.5.2. AmberAir Compact VEKA INT EKO 2000

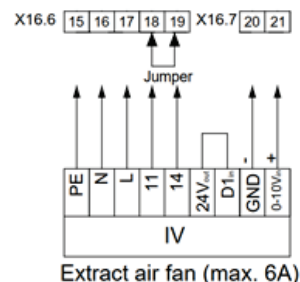

Figure 8.5.3. AmberAir Compact VEKA INT EKO 3000-4000

## 8.6. EXTRACT AIR FILTER PRESSURE SWITCH

AmberAir Compact VEKA INT EKO 3000-4000 units have designated input for external extract air filter differential pressure switch – type NC.

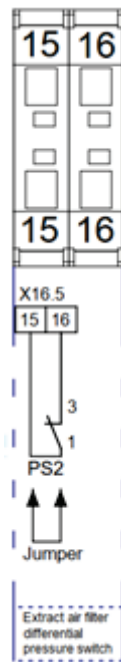

Figure 8.6.1. AmberAir Compact VEKA INT EKO 3000-4000 E

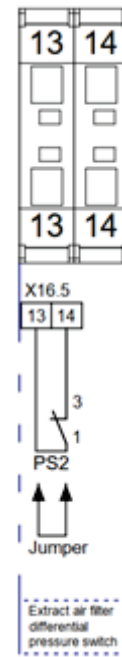

Figure 8.6.2. AmberAir Compact VEKA INT EKO 3000-4000 W

8.7. RECOMMENDED SCHEME FOR CONNECTION OF INTERNAL AND EXTERNAL COMPONENTS

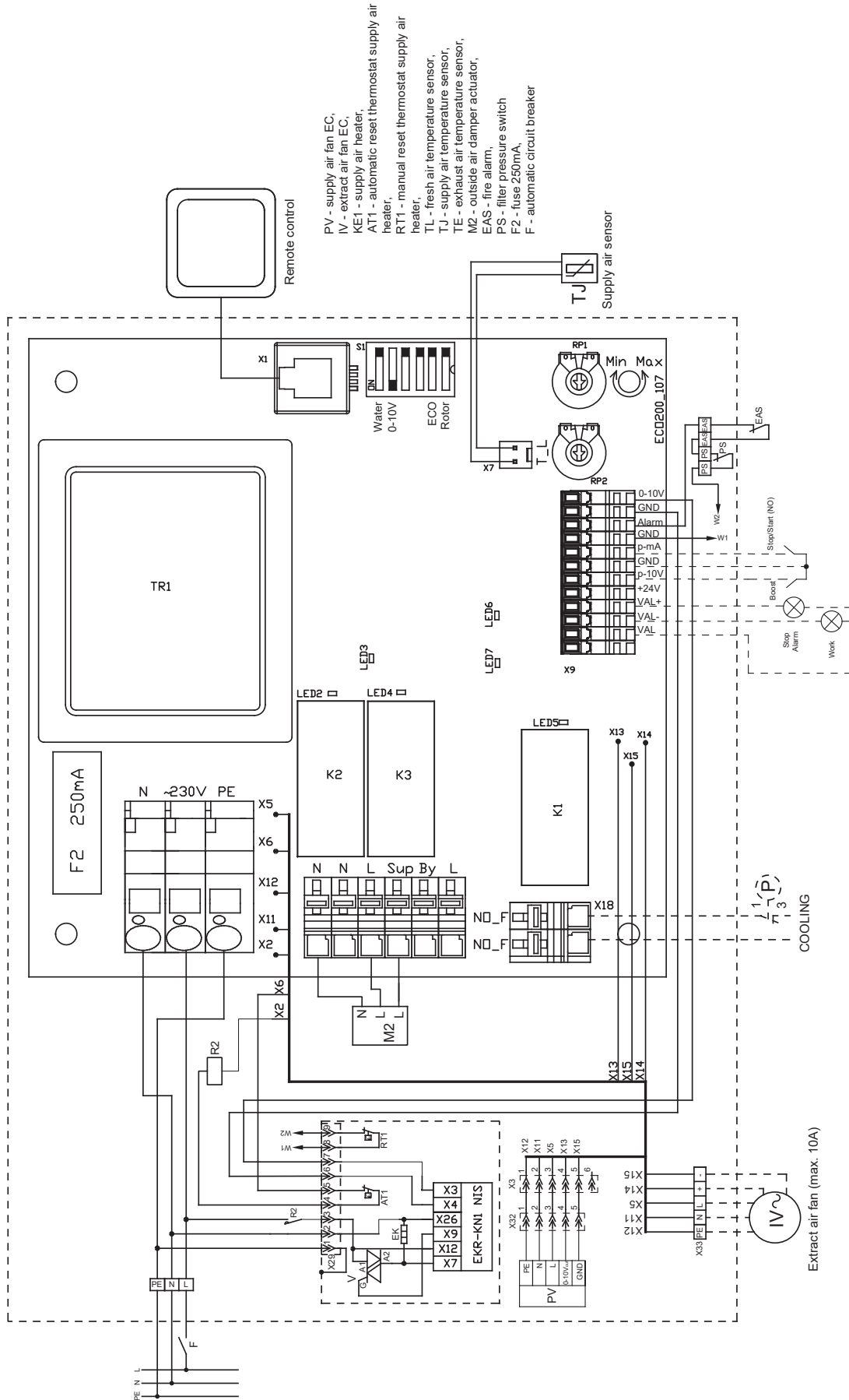
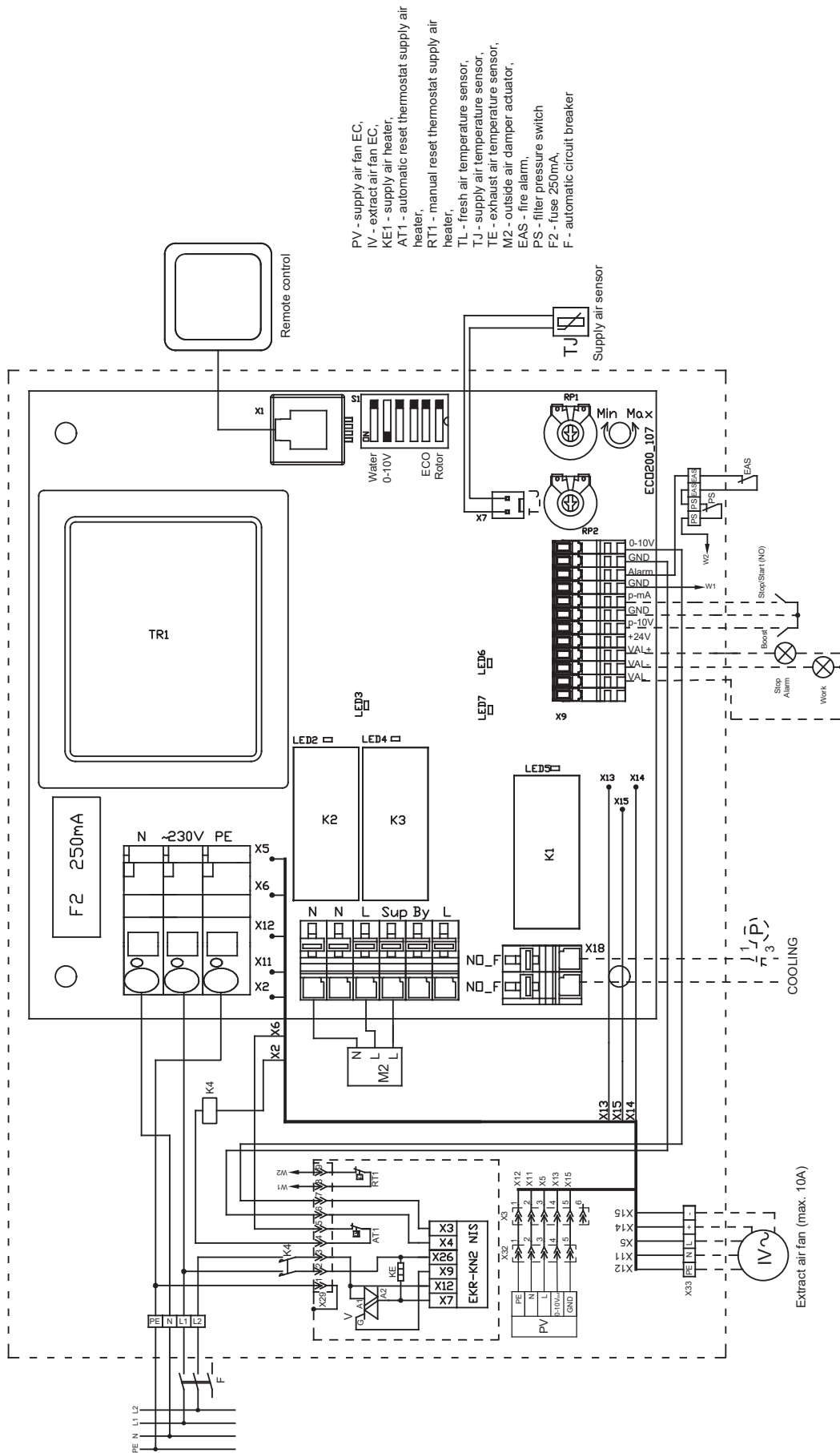

Figure 8.7.1. AmberAir Compact VEKA INT EKO 400-1.2; 2.0; 700-2.4



PV - supply air fan EC,  
 IV - extract air fan EC,  
 KE1 - supply air heater,  
 AT1 - automatic reset thermostat supply air heater,  
 RT1 - manual reset thermostat supply air heater,  
 TL - fresh air temperature sensor,  
 TJ - supply air temperature sensor,  
 TE - exhaust air temperature sensor,  
 M2 - outside air damper actuator,  
 EAS - fire alarm,  
 PS - filter pressure switch  
 F2 - fuse 250mA,  
 F - automatic circuit breaker

Figure 8.7.2. AmberAir Compact VEKA INT EKO 400-5.0; 700-5.0

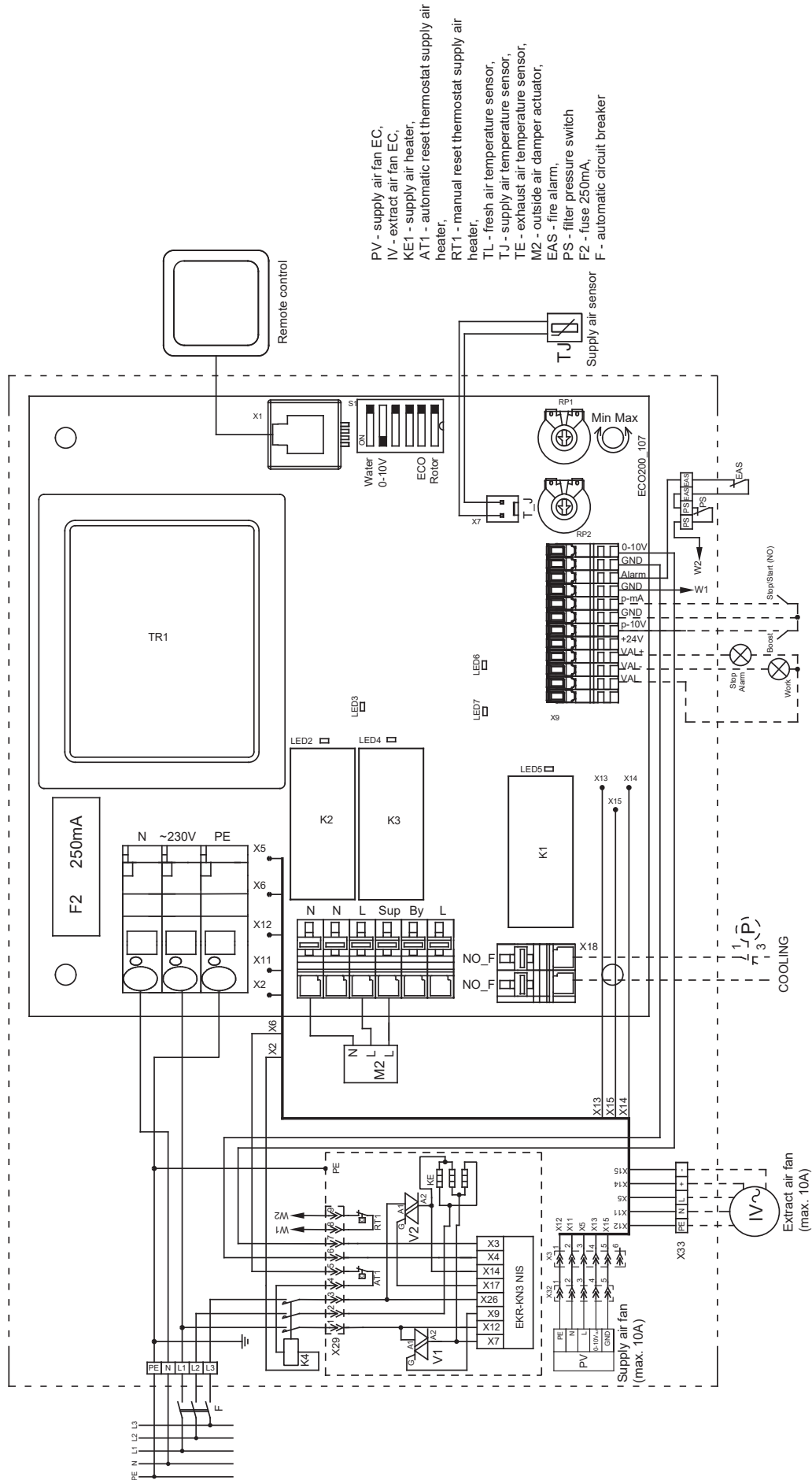

Figure 8.7.3. AmberAir Compact VEKA INT EKO 700-9.0

- PV - supply air fan EC,
- IV - extract air fan EC,
- KE1 - supply air heater,
- AT1 - automatic reset thermostat supply air heater,
- RT1 - manual reset thermostat supply air heater,
- TL - fresh air temperature sensor,
- TJ - supply air temperature sensor,
- TE - exhaust air temperature sensor,
- M2 - outside air damper actuator,
- EAS - fire alarm,
- PS - filter pressure switch
- F2 - fuse 250mA,
- F - automatic circuit breaker

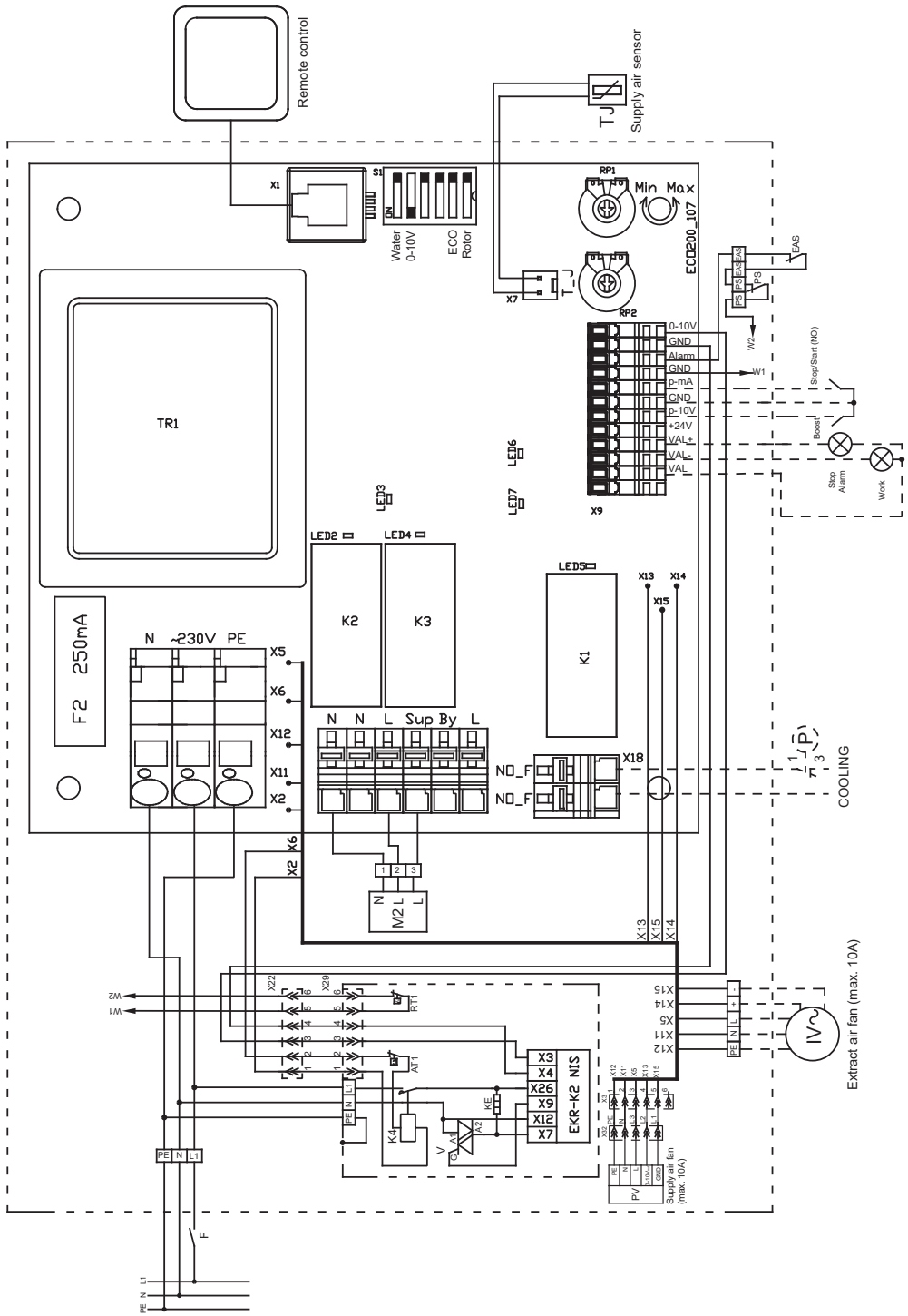

Figure 8.7.4. AmberAir Compact VEKA INT EKO 1000-2.4

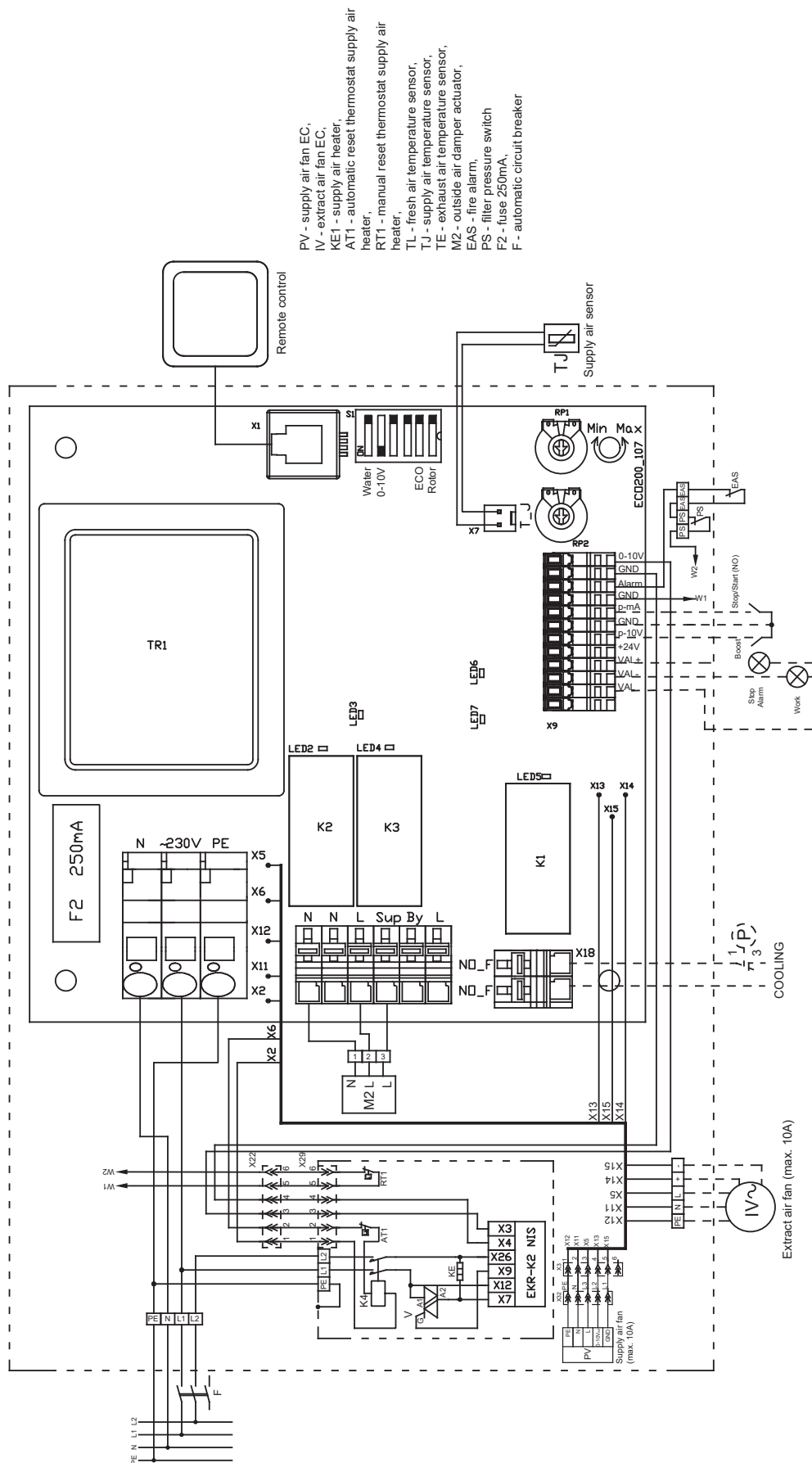

Figure 8.7.5. AmberAir Compact VEKA INT EKO 1000-5.0

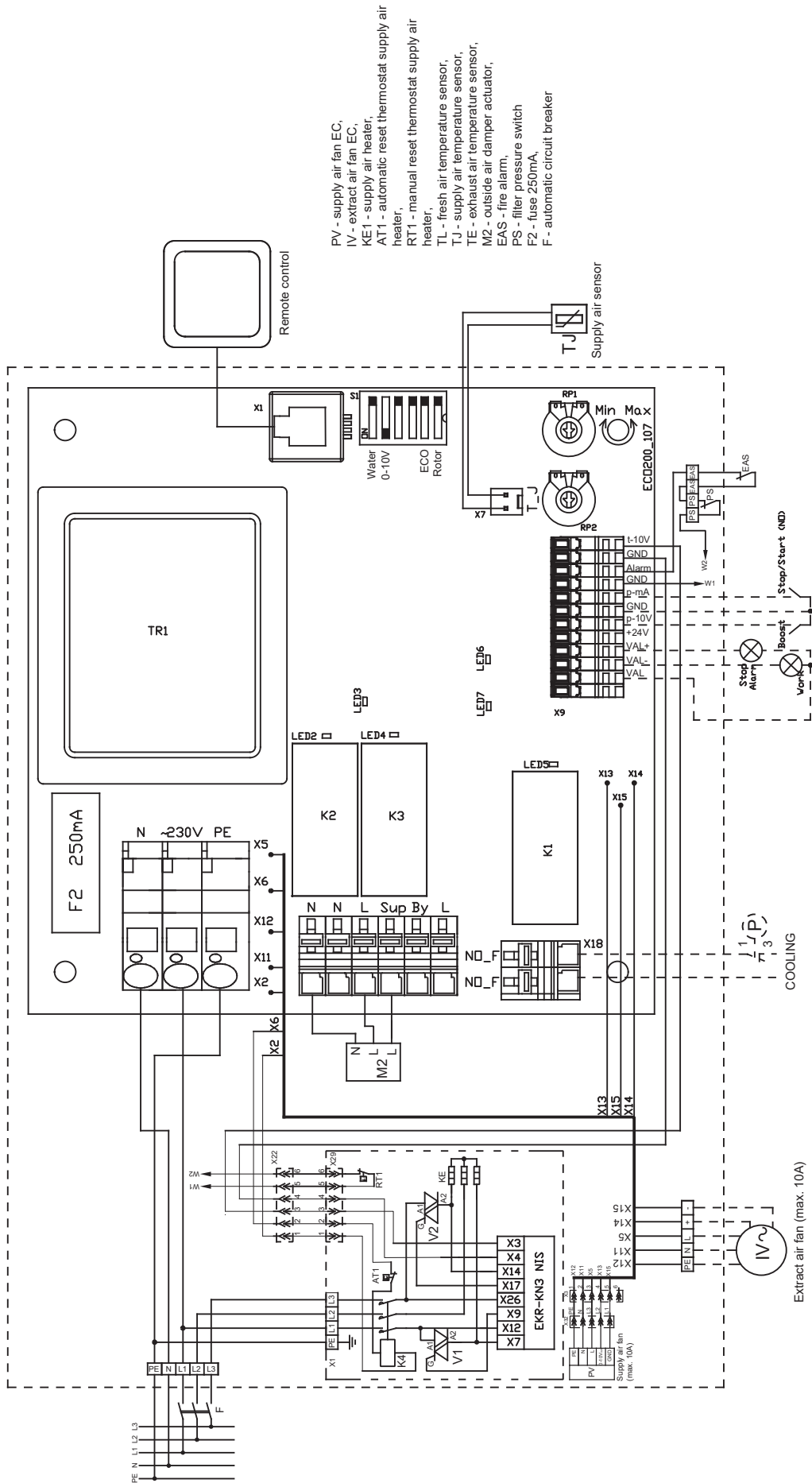

Figure 8.7.6. AmberAir Compact VEKA INT EKO 1000-9.0; 12



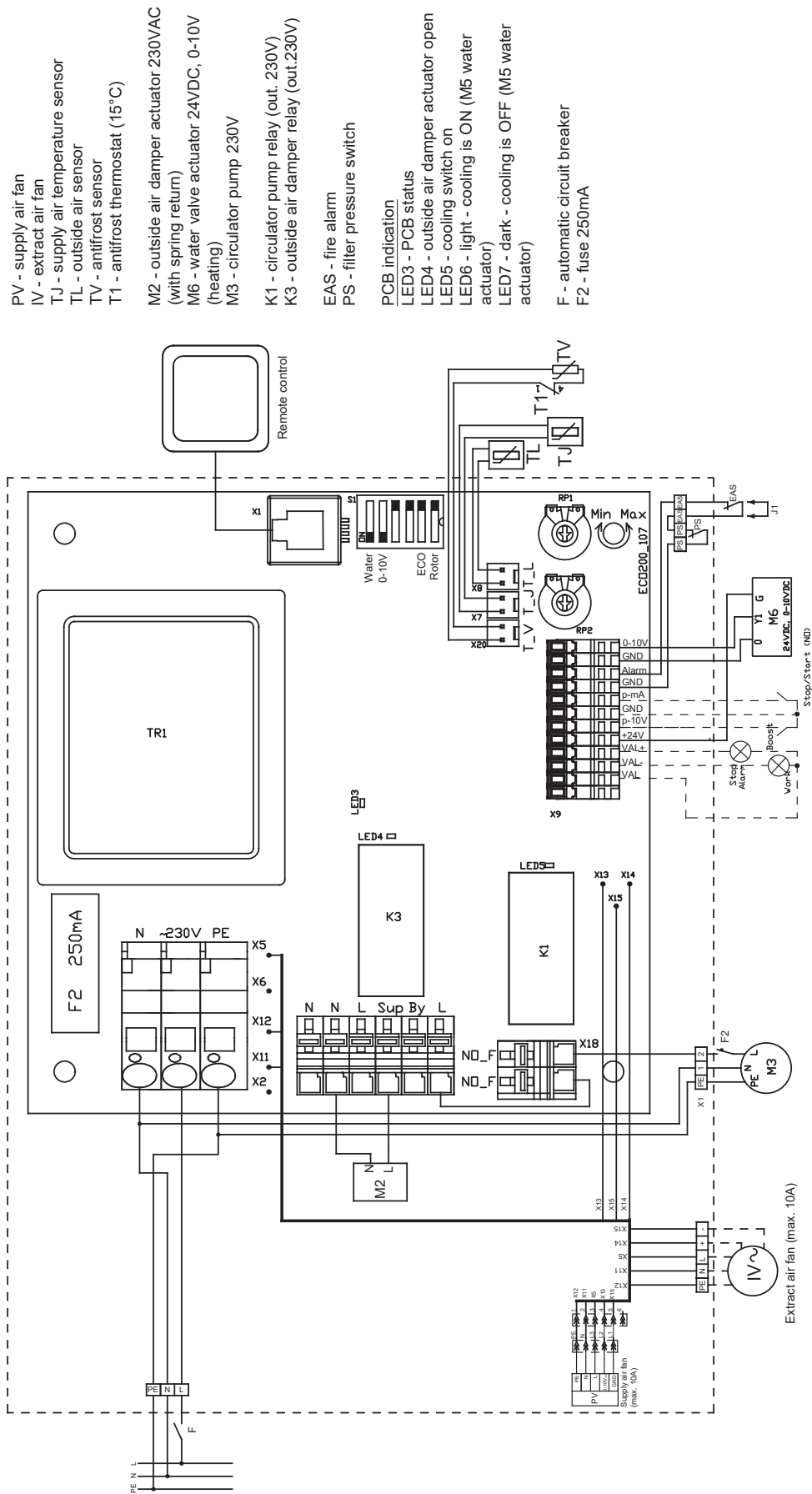
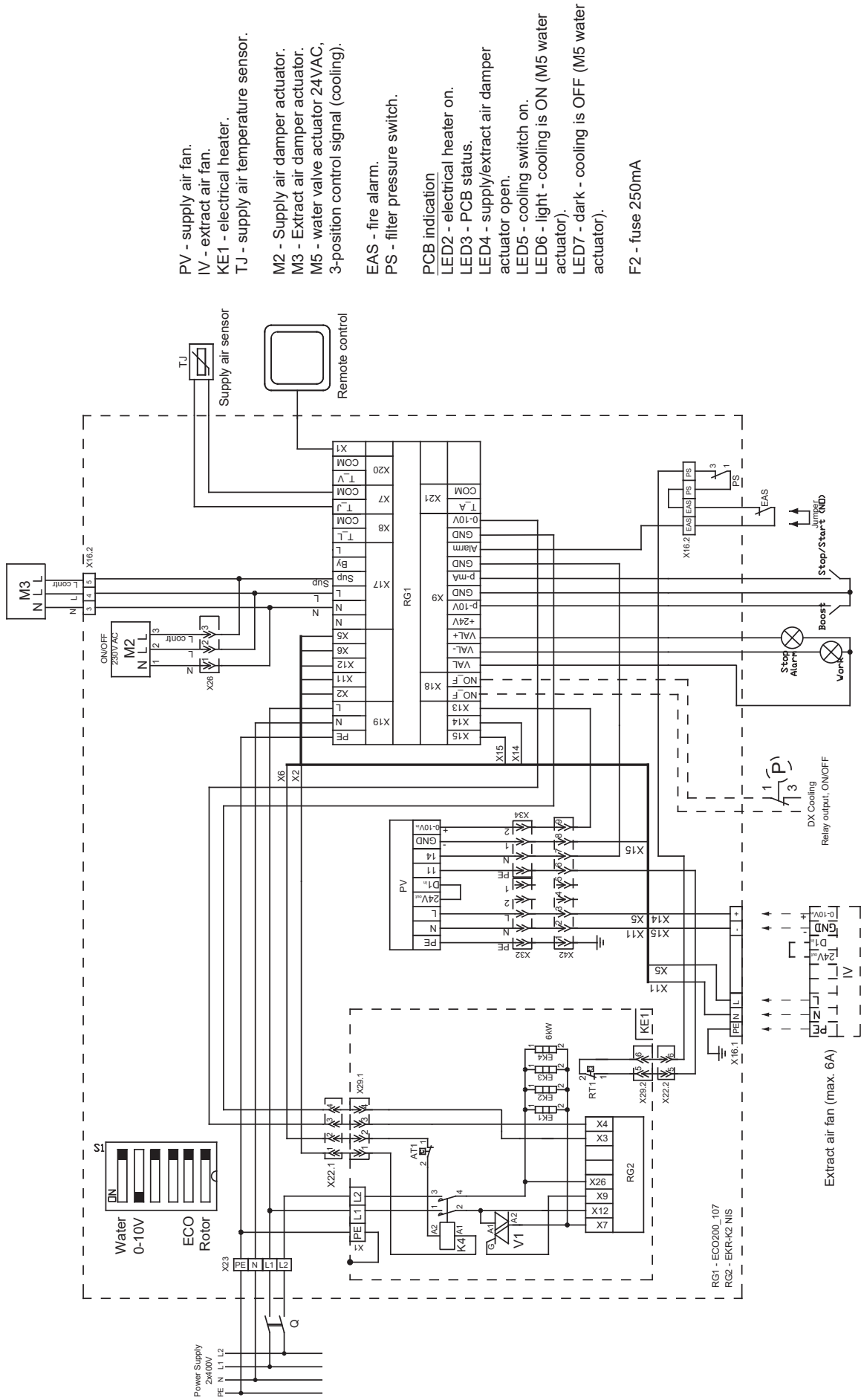

Figure 8.7.7. AmberAir Compact VEKA INT EKO 1000-14.4 W



- PV - supply air fan.
- IV - extract air fan.
- KE1 - electrical heater.
- TJ - supply air temperature sensor.
- M2 - Supply air damper actuator.
- M3 - Extract air damper actuator.
- M5 - water valve actuator 24VAC, 3-position control signal (cooling).
- EAS - fire alarm.
- PS - filter pressure switch.
- PCB indication
- LED2 - electrical heater on.
- LED3 - PCB status.
- LED4 - supply/extract air damper actuator open.
- LED5 - cooling switch on.
- LED6 - light - cooling is ON (M5 water actuator).
- LED7 - dark - cooling is OFF (M5 water actuator).
- F2 - fuse 250mA

Figure 8.7.8. AmberAir Compact VEKA INT EKO 2000-6.0

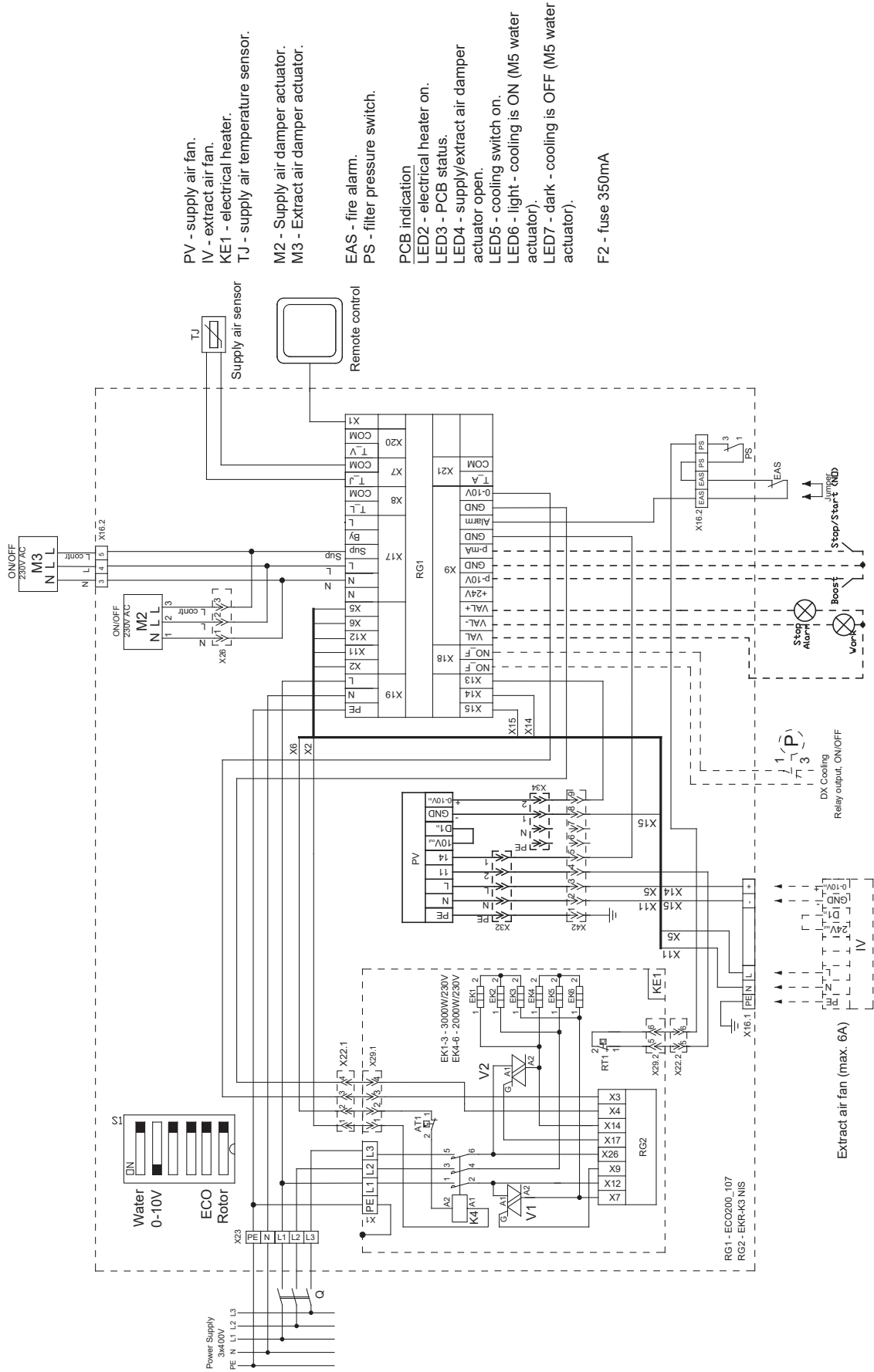
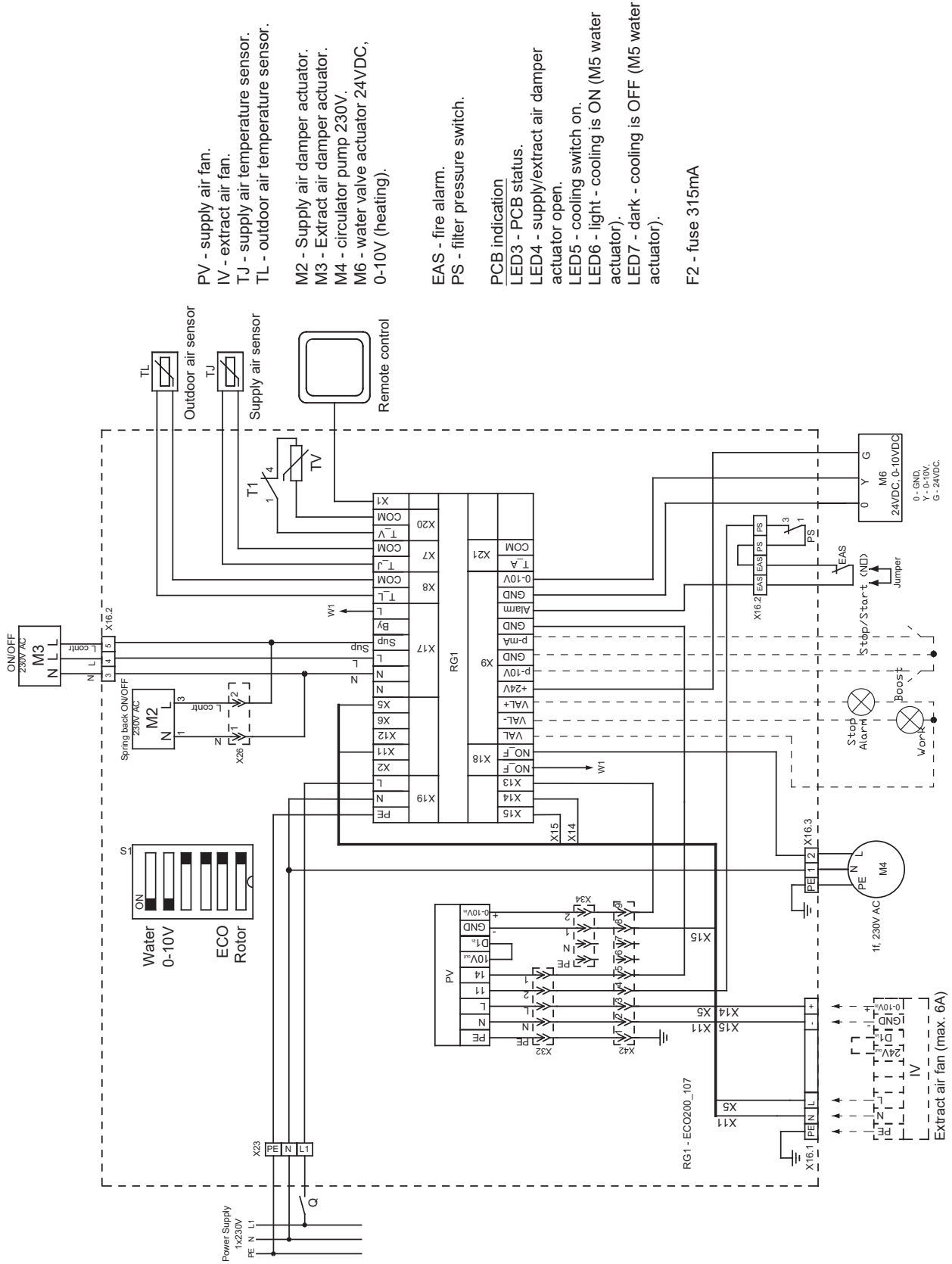

Figure 8.7.9. AmberAir Compact VEKA INT EKO 2000-15; 21



- PV - supply air fan.
- IV - extract air fan.
- TJ - supply air temperature sensor.
- TL - outdoor air temperature sensor.
- M2 - Supply air damper actuator.
- M3 - Extract air damper actuator.
- M4 - circulator pump 230V.
- M6 - water valve actuator 24VDC, 0-10V (heating).
- EAS - fire alarm.
- PS - filter pressure switch.
- PCB indication
- LED3 - PCB status.
- LED4 - supply/extract air damper actuator open.
- LED5 - cooling switch on.
- LED6 - light - cooling is ON (M5 water actuator).
- LED7 - dark - cooling is OFF (M5 water actuator).
- F2 - fuse 315mA

Figure 8.7.10. AmberAir Compact VEKA INT EKO 2000-26.9W

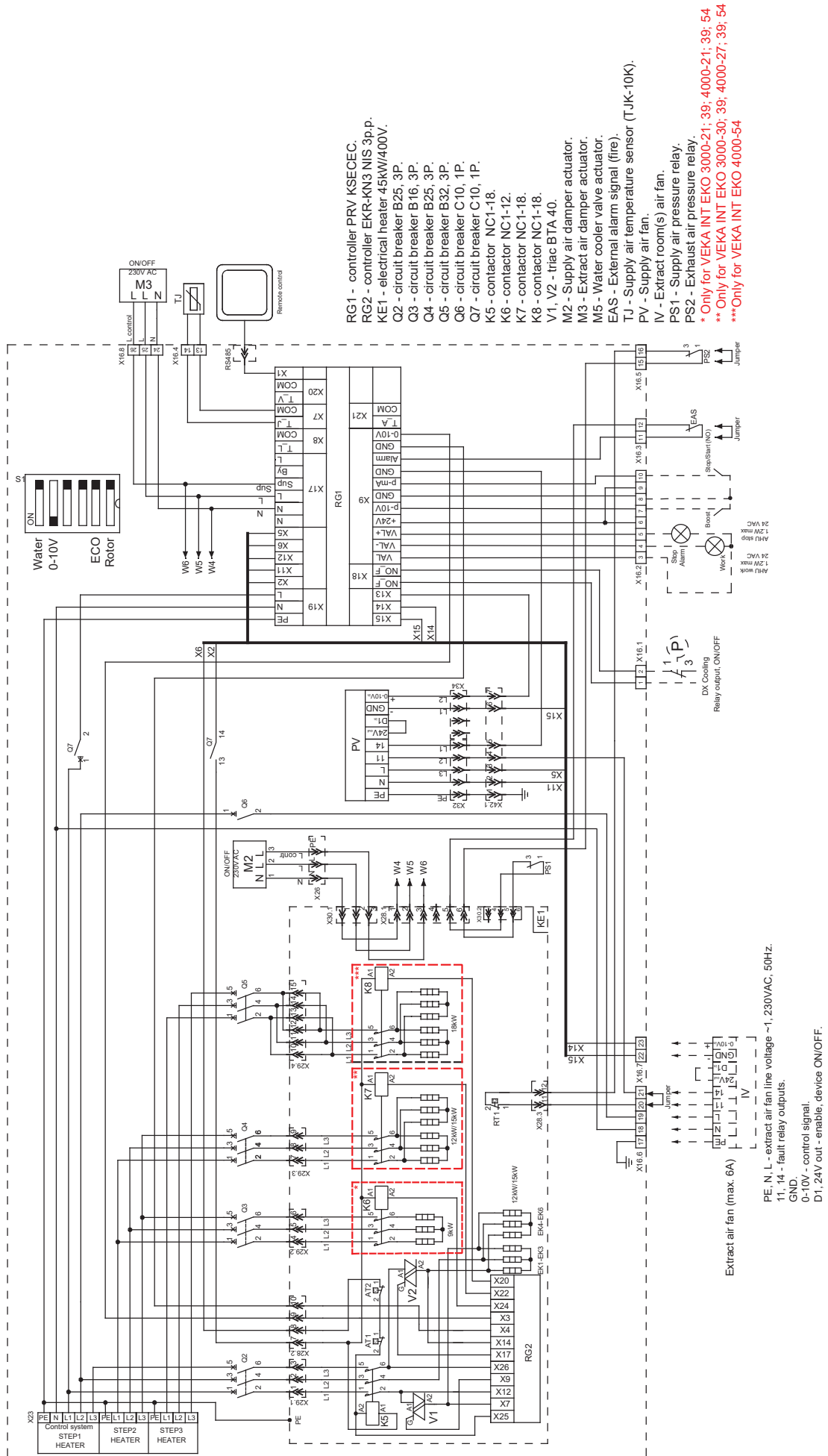

Figure 8.7.11. AmberAir Compact VEKA INT EKO 3000-4000 with electrical heater

- RG1 - controller PRV KSWCEC.
- F1 - fuse 6.3A (size 5x20).
- F2 - fuse 1A (size 5x20).
- F3 - fuse 6.3A (size 5x20).
- M2 - Supply air damper actuator.
- M3 - Extract air damper actuator.
- M4 - Water heater circulatory pump.
- M6 - Water heater valve actuator.
- EAS - External alarm signal (fire).
- TJ - Supply air temperature sensor (TIK-10K).
- TV - Fresh (ambient) air temperature sensor.
- TV - Water heater antifreeze return heat carrier temperature sensor.
- T1 - Water heater antifreeze thermostat.
- PV - Supply air fan.
- IV - Extract room(s) air fan.
- PS1 - Supply air pressure relay.
- PS2 - Exhaust air pressure relay.

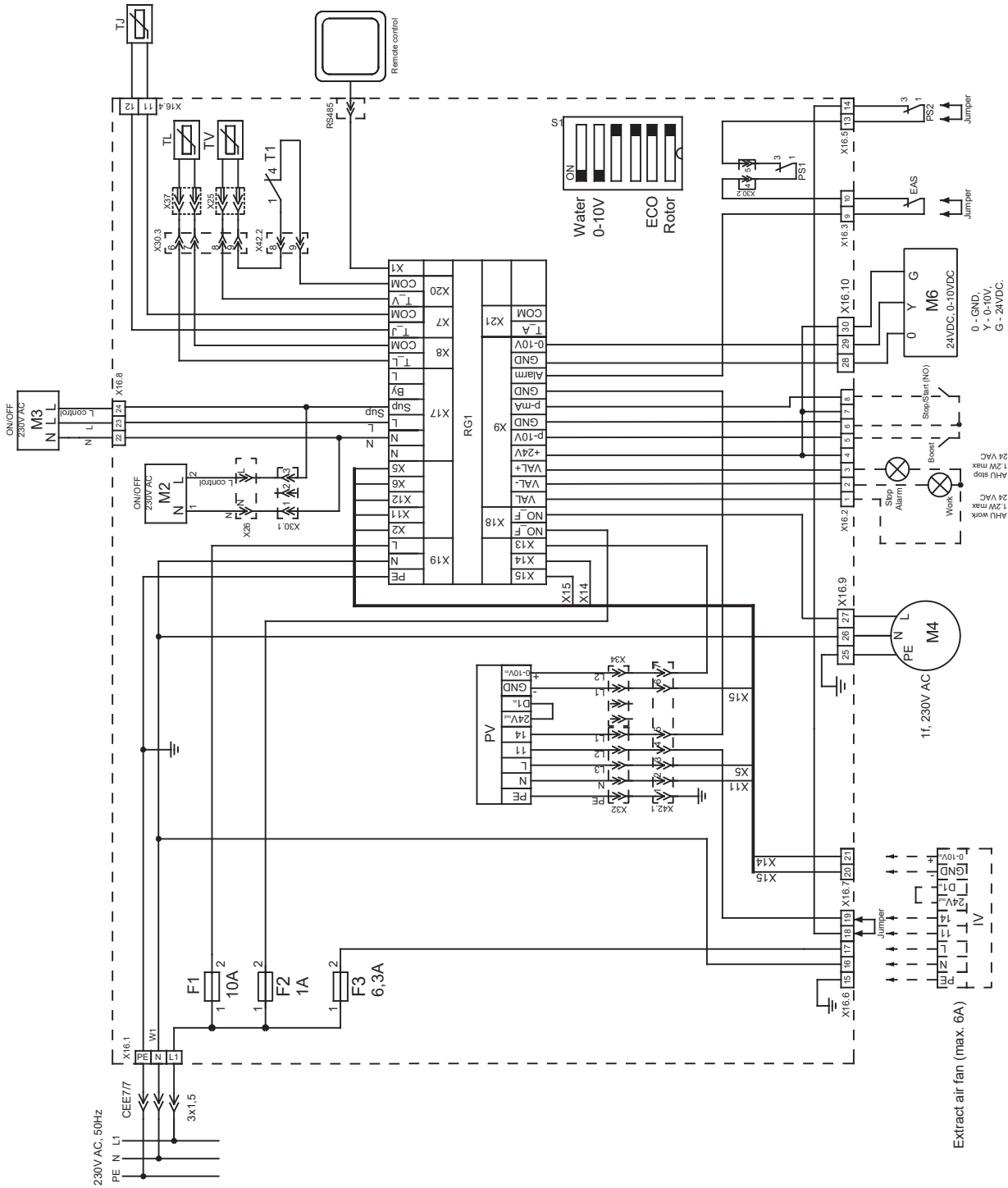

Figure 8.7.12. AmberAir Compact VEKA INT EKO 3000-4000 with water heater

## 9. POSSIBLE FAULTS AND TROUBLESHOOTING

FAILURE	CAUSE	EXPLANATION / CORRECTIVE ACTIONS
Unit is not operating	No supply voltage	Check whether the device is connected to the power network
	Protection device is off or a current leakage relay is active (if installed by the installer)	Switch on only if the unit condition has been evaluated by a qualified electrician. If the system failed, the failure <b>MUST BE</b> rectified prior to switching it on.
Air supply heater or pre-heater is not operating or malfunctioning (if installed)	Too low air flow in air ducts activates automatic protection	Check if air filters are not clogged Check if fans are rotating
	Manual protection is activated	Possible heater or unit failure. <b>MUST</b> contact the servicing staff for failure detection and its elimination.
Too low air flow at rated fan speed	Clogged supply and/or extract air filter(s)	Filter replacement needed
Filters are clogged and no message is shown on the remote control	Wrong time in filter timers or their switch is broken, or its pressure is set improperly.	Shorten filter timer time to the message of clogged filters or replace the pressure switch of the filters, or set their proper pressure.

## 10. ECODESIGN DATA TABLE

<b>AMBERAIR COMPACT VEKA INT EKO</b>		<b>400</b>	<b>700</b>	<b>1000</b>	<b>1000 W</b>	<b>2000</b>	<b>2000 W</b>
Topology		Bidirectional	Bidirectional	Bidirectional	Bidirectional	Bidirectional	Bidirectional
Type of drive (fan)		Variable	Variable	Variable	Variable	Variable	Variable
Nominal NRVC flow rate	[ m <sup>3</sup> /s ]	0,1	0,12	0,21	0,21	0,37	0,37
Effective electric power input	[ W ]	38,8	81,1	96,1	110	242	281
SFPint	[ W/(m <sup>3</sup> /s) ]	158,3	162,8	158	230	75,3	51,7
Maximum internal SFP	[ W/(m <sup>3</sup> /s) ]	230	230	230	230	230	230
Face velocity	[ m/s ]	0,9	1,7	1,3	1,3	1,4	1,4
Nominal external pressure	[ Pa ]	100	100	150	150	250	250
Internal pressure drop of ventilation components	[ Pa ]	84,9	78	92,7	153	34,7	25,7
Static efficiency of fans used in accordance with Regulation No 327/2011	[ % ]	53,6	47,9	58,7	66,3	46	49,8
Declared maximum external leakage rates (CAL(R) @ +400 Pa)	[ % ]	4	4	4	4	4	4
Declared maximum external leakage rates (CAL(R) @ -400 Pa)	[ % ]	4	4	4	4	4	4
Filter class		C	C	C	C	C	C
Visual filter warning		Pressure device	Pressure device	Pressure device	Pressure device	Pressure device	Pressure device
Casing sound power level	dB(A)	45,4	50,8	54,3	54,8	67,8	58,2
ErP Compliance		2018	2018	2018	-	2018	2018
Internet address for disassembly instructions		<a href="https://select.salda.it">https://select.salda.it</a>					

<b>AMBERAIR COMPACT VEKA INT EKO</b>		<b>3000</b>	<b>3000 W</b>	<b>4000</b>	<b>4000 W</b>
Topology		Bidirectional	Bidirectional	Bidirectional	Bidirectional
Type of drive (fan)		Variable	Variable	Variable	Variable
Nominal NRVC flow rate	[ m <sup>3</sup> /s ]	0,68	0,68	0,89	0,89
Effective electric power input	[ W ]	495	509	580	651
SFPint	[ W/(m <sup>3</sup> /s) ]	139,2	135,5	143,8	181,9
Maximum internal SFP	[ W/(m <sup>3</sup> /s) ]	230	230	230	230
Face velocity	[ m/s ]	1,6	1,6	2,1	2,1
Nominal external pressure	[ Pa ]	250	250	250	250
Internal pressure drop of ventilation components	[ Pa ]	67,8	67,8	88,3	113
Static efficiency of fans used in accordance with Regulation No 327/2011	[ % ]	48,8	50	61,4	61,9
Declared maximum external leakage rates (CAL(R) @ +400 Pa)	[ % ]	4	4	4	4
Declared maximum external leakage rates (CAL(R) @ -400 Pa)	[ % ]	4	4	4	4
Filter class		C	C	C	C
Visual filter warning		Pressure device	Pressure device	Pressure device	Pressure device
Casing sound power level	dB(A)	61,8	62	61,1	62,2
ErP Compliance		2018	2018	2018	2018
Internet address for disassembly instructions		<a href="https://select.salda.it">https://select.salda.it</a>			



## 11. DECLARATION OF CONFORMITY

Manufacturer

**SALDA, UAB**  
**Ragainės g. 100**  
**LT-78109 Siauliai, Lithuania**  
**Tel.: +370 41 540415**  
**www.salda.lt**

Hereby confirms that the following products - Air handling units:

**AmberAir Compact VEKA INT EKO\***

**(where by „\*“ indicates possible unit installation type and modification)**

Provided it was delivered and installed in the facility in accordance with the included installation instructions, comply with all applicable requirements in the following directives:

**Machinery Directive 2006/42/EC**  
**EMC Directive 2014/30/EU**  
**Low Voltage Directive 2014/35/EU**  
**Ecodesign Directive 2009/125/EC**  
**RoHS 2 Directive 2011/65/EU**

The following regulations are applied in applicable parts:

**Ecodesign requirements for ventilation units Nr. 1253/2014**  
**Energy labeling of residential units Nr. 1254/2014**

The following harmonized standards are applied in applicable parts:

LST EN 13141-7:2011 - Ventilation for buildings - Performance testing of components/products for residential ventilation - Part 7: Performance testing of a mechanical supply and exhaust ventilation units (including heat recovery) for mechanical ventilation systems intended for single family dwellings.  
 LST EN ISO 12100:2011 - Safety of machinery - General principles for design - Risk assessment and risk reduction.  
 LST EN 60204-1:2018 - Safety of machinery - Electrical equipment of machines - Part 1: General requirements.  
 LST EN 60335-1:2012 - Household and similar electrical appliances. Safety. Part 1: General requirements.  
 LST EN 60529:1999/A2:2014/AC:2019 - Degrees of protection provided by enclosures (IP code).  
 LST EN 61000-6-1:2007 - Electromagnetic compatibility (EMC) .Part 6-1: Generic standards - Immunity for residential, commercial and light-industrial environments.  
 LST EN 61000-6-4:2007/A11:2011 - Electromagnetic compatibility (EMC) .Part 6-4: Generic standards - Emission standard for industrial environments.

Should any alterations be made in the products, this declaration will no longer apply.

**Quality:** SALDA UAB activities are in line with the international quality management system standard **ISO 9001:2015**.

Date 2022-05-17



Giedrius Taujenis  
 Product Manager

## 12. WARRANTY

1. All equipment manufactured in our factory is checked in operating conditions and tested before delivery. Test protocol is supplied together with the unit. The equipment is shipped in good working condition to the end-client. The unit is warranted for the period of two years from the invoice date.
2. If equipment is found to have been damaged during transportation, a claim should be made against carrier, as we assume no responsibility for such damage.
3. This warranty does not apply:
  - 3.1. when transportation, storage, installation and maintenance instructions of the unit are violated;
  - 3.2. when the equipment is improperly maintained, mounted - inadequate maintenance;
  - 3.3. when the equipment without our knowledge and permission has been upgraded or unskilled repairs were made;
  - 3.4. when the unit was used not for its original purpose.
  - 3.5. Company SALDA UAB is not responsible for potential loss of property or personal injury in cases where AHU is manufactured without a control system and the control system will be installed by the client or third parties. The manufacturer's warranty does not cover devices that will be damaged by installing the control system.
4. This warranty does not apply at these malfunction cases:
  - 4.1. mechanical damage;
  - 4.2. damage caused by entering outside objects, materials, liquids;
  - 4.3. damage caused by natural disaster, accident (voltage change in the electricity network, lightning, etc..).
5. The company assumes no liability for its products either directly or indirectly damage, if the damage is caused by failure to comply with installation and mounting regulations, deliberate or careless users or third-party behavior.

These conditions are readily discernable when the equipment is returned to our factory for inspection.

If the direct client determines that equipment is found to be faulty, or a breakdown occurred, he should inform the manufacturer within five working days and deliver the equipment to manufacturer. Delivery costs should be covered by customer.



**Manufacturer reserves the right to change this technical passport any time without prior notice, if some typographic errors or inaccurate information is found, as well as after improving the apps and/or the devices. Such changes will be included in the new issues of the technical passport. All illustrations are just for information and thus may differ from the original device.**

### 12.1. LIMITED WARRANTY COUPON

Warranty term  
**24 months\***

I received complete package and technical manual of the product ready for usage. I have read warranty terms and conditions and agree with them:

.....  
 Customer's signature

\*refer to WARRANTY CONDITIONS

*Dear User, we appreciate your choice and do hereby guarantee that all ventilation equipment manufactured by our Company is inspected and thoroughly tested. An operational and high-quality product is sold to the direct buyer and shipped from the territory of the factory. It is provided with a 24-month warranty since invoice issue date.*

*Your opinion is important to us, thus we always look forward to hearing your comments, feedback, or suggestions regarding technical and operational characteristics of the Products.*

*In order to avoid any misunderstandings, please read the instructions for installation and operation of the product as well as other technical documents of the product carefully. The number of the Limited Warranty Coupon and serial number of the product specified on the silver identification sticker attached to the housing must match.*

*The Limited Warranty Coupon shall be valid provided that the seller's stamps and records are clear. It is not allowed to change, delete, or rewrite the data specified on it in any manner – such a coupon shall be invalid.*

*With this Limited Warranty Coupon the manufacturer confirms one's obligations to implement the imperative requirements established by effective laws on protection of consumer rights in the event of identification of any defects of the products.*

*The manufacturer reserves the right to refuse provision of free warranty servicing in cases when the warranty conditions listed below are disregarded.*



## PRODUCT MAINTENANCE TABLE

Product name*		
SERIAL number*		
installation	interval	Date
Fan cleaning	Once per year**	_____
Heat-exchanger cleaning	Once per year**	_____
Filter replacement	Every 3-4 months**	_____
		_____
		_____
		_____
		_____
		_____
		_____

\* - Look at the product label.  
 \*\* - At least.

NOTE. The customer shall be required to complete the Product Maintenance Table.

### MANUALS IN OTHER LANGUAGES

DE



<https://select.salda.lt/file/aa-compact-veka-int400-4000eko-de>

LT



<https://select.salda.lt/file/aa-compact-veka-int400-4000eko-lt>

PL



<https://select.salda.lt/file/aa-compact-veka-int400-4000eko-pl>

RU



<https://select.salda.lt/file/aa-compact-veka-int400-4000eko-ru>



MAN000407

