

Modification	Date	2023-03-17	Control board for AHU	Heater	Project No.	Offer nr.	= 219.1813
Date	justasablis						
Name	Appr.		Replaced by		Page	2	
Original			Replaced by		Page	2 / 12	

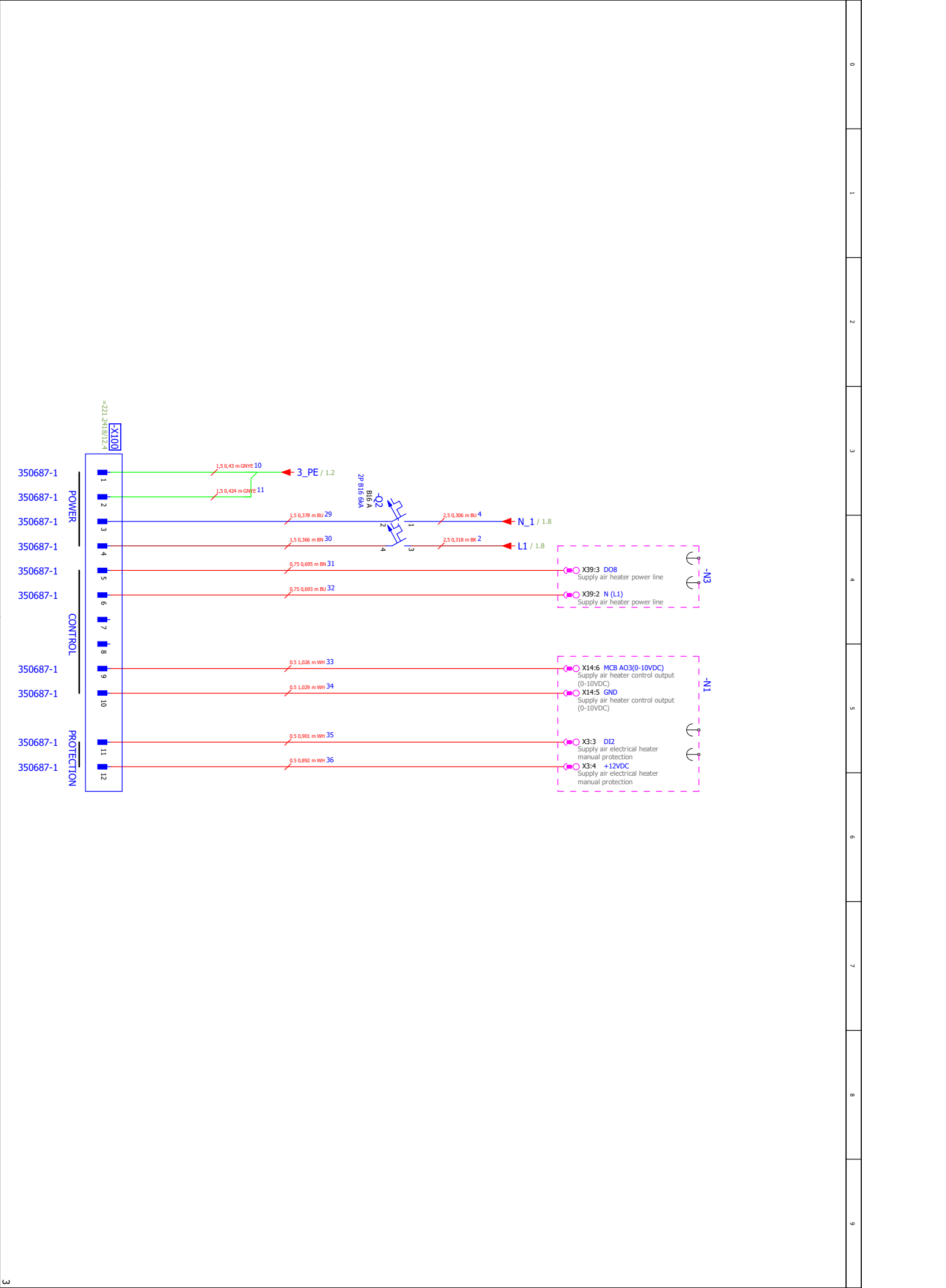

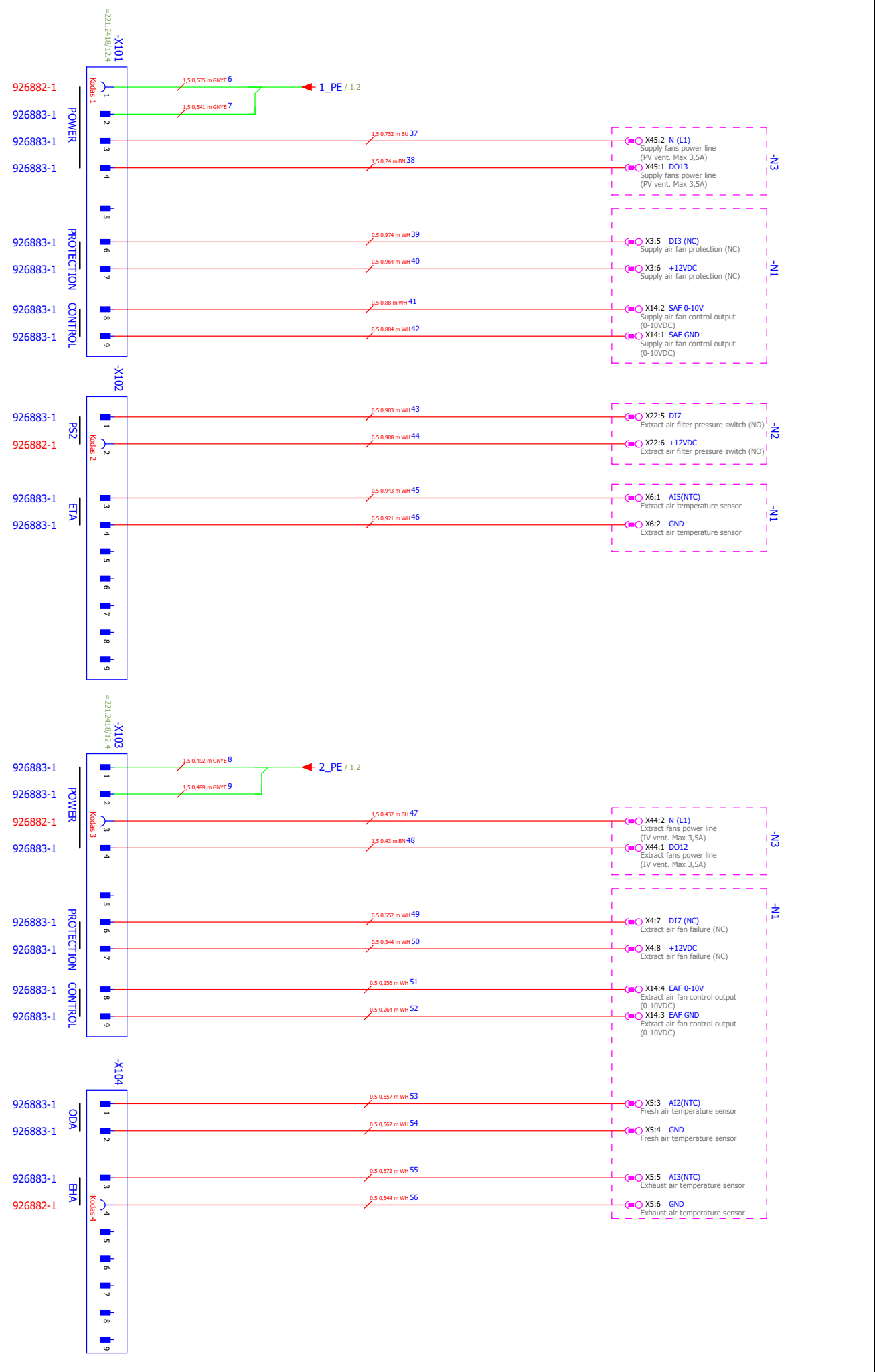

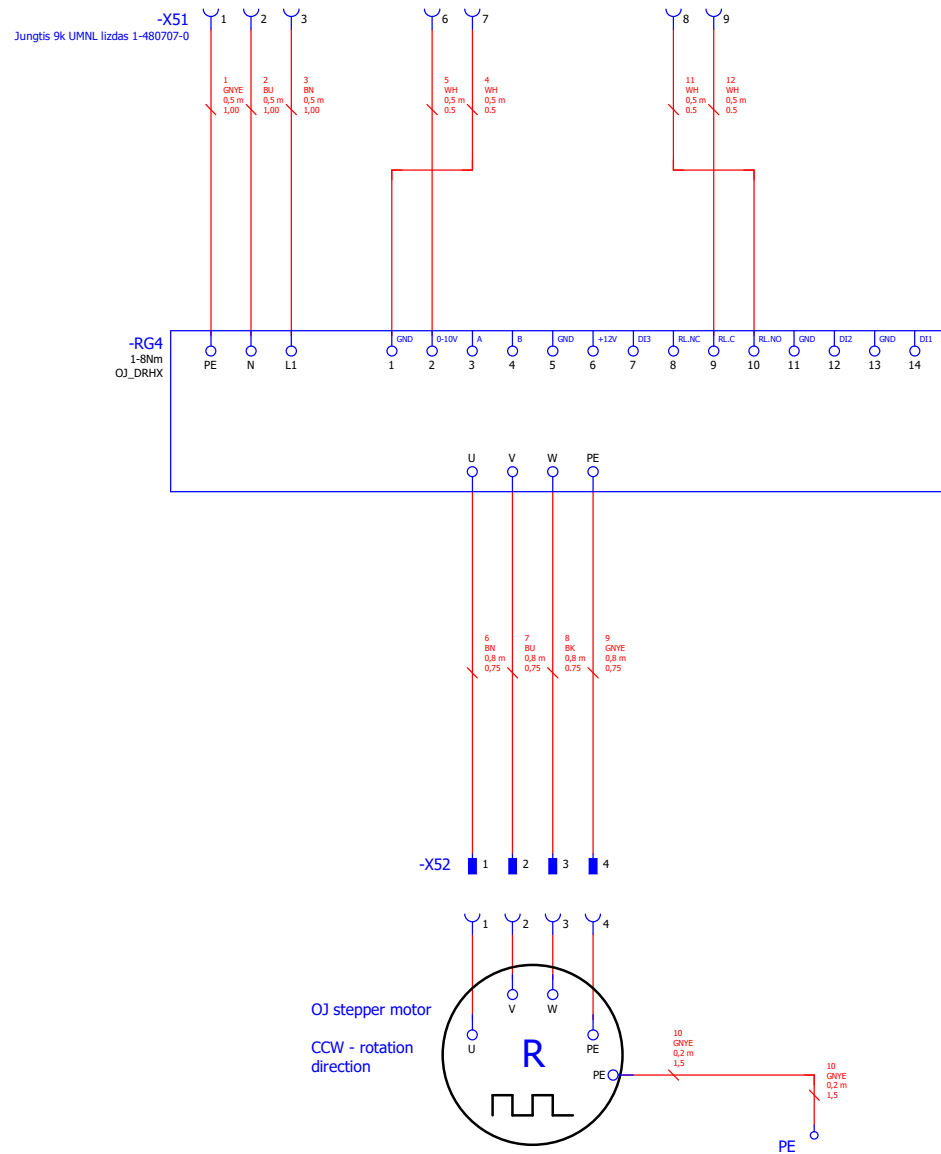

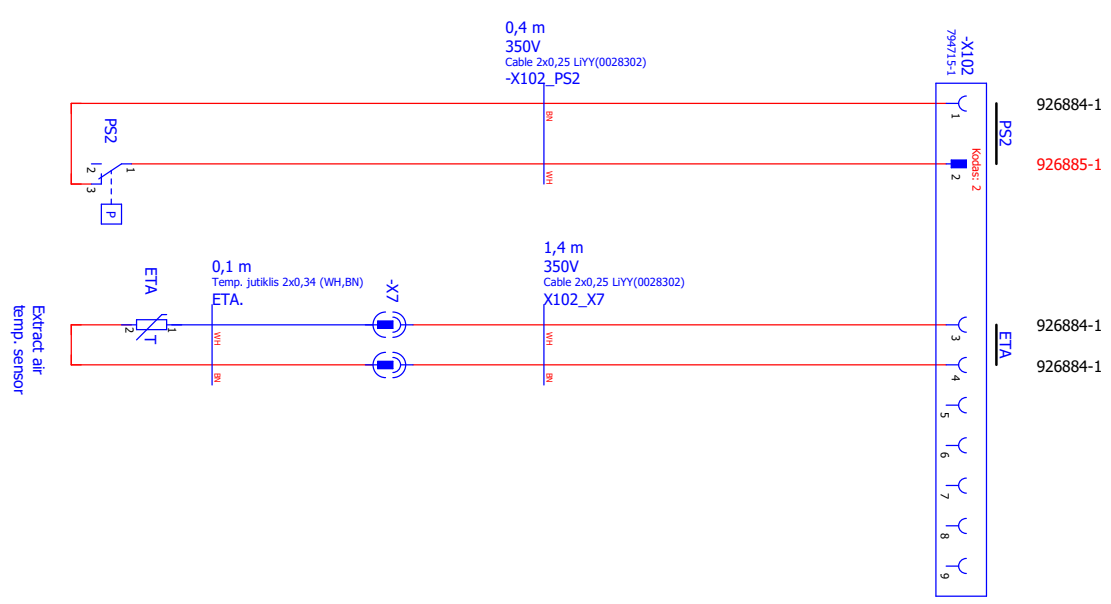
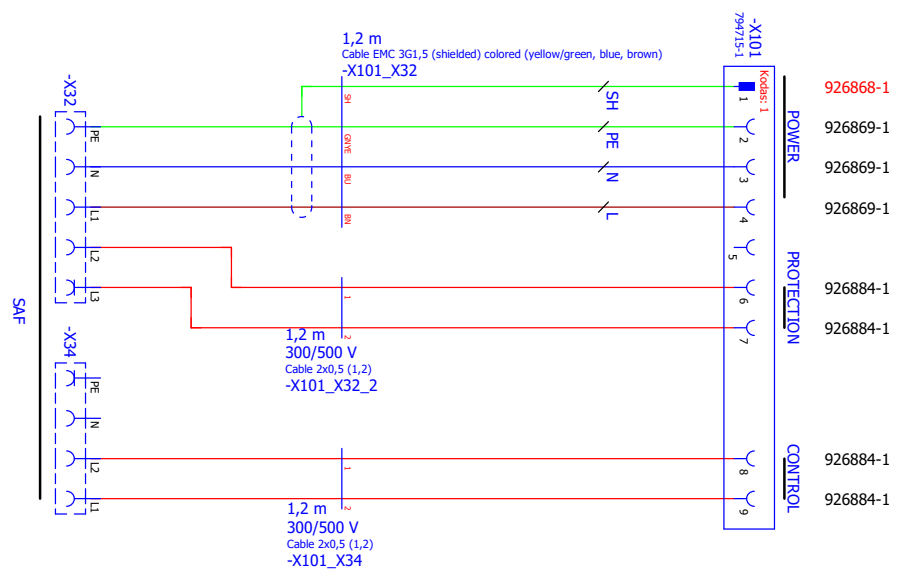

Modification		Date	2023-03-17
Date		Ed.	justasabalis
Name		Appr.	
Original		Replaced by	
Replacement of		Replaced by	
SALDA			
Project No.	Z21.2419.1-PS		
Offer nr.			
Page	= 221.2419		
Page	1 / 10		

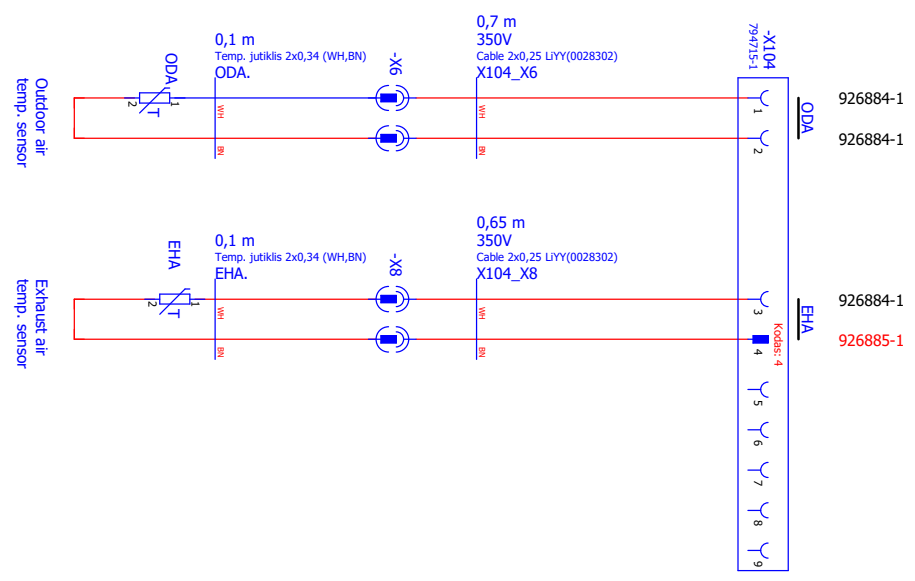
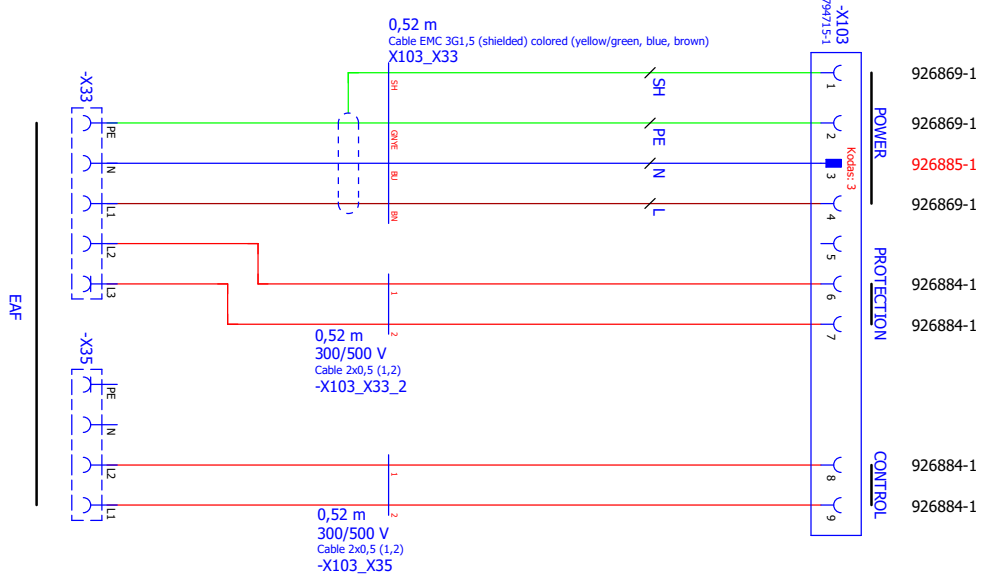

Modification	Date	2023-03-17
Date	Edi.	justasabalis
Name	Appr.	
Original		
Replacement of	Replaced by	



Z21.2419.2-FS

Project Nr.	Offer nr.	Page
		2 / 10

= Z21.2419

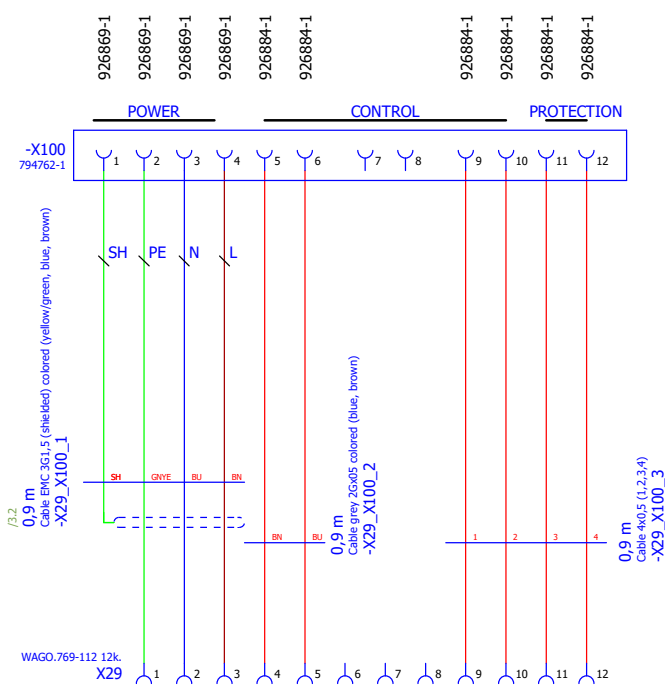

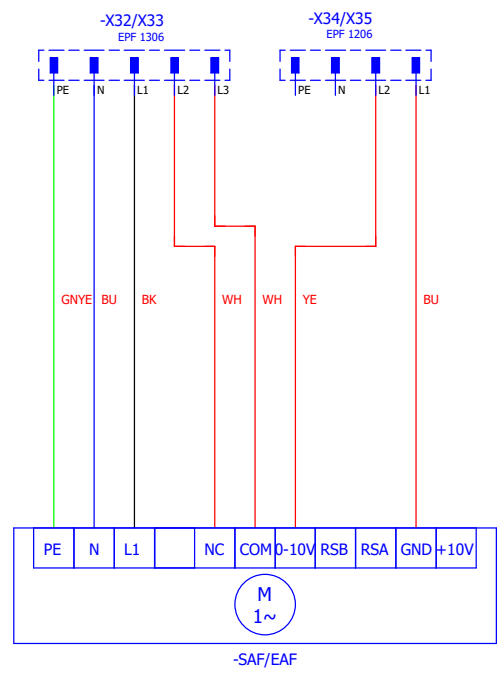

			Date	2023-03-08
			Ed.	justasbalsys
			Appr.	
Modification	Date	Name	Original	Replaced by



Fans	
Project Nr.	Offer nr.

= SP148 (EBM fan)	
+	
Page	1
Page	1 / 1

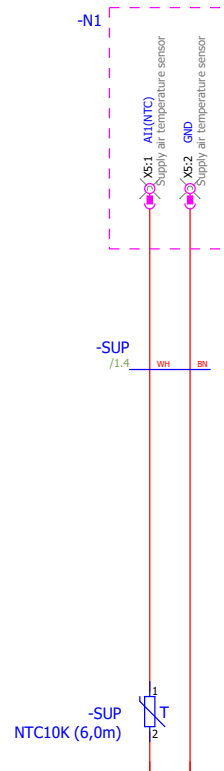

			Date	2023-01-20		
			Ed.	justasbalys		
			Appr.			
Modification	Date	Name	Original		Replacement of	Replaced by



SUP to MCB

		= SP150 (SUP connection to MCB)	
		+	
Project Nr.	Offer nr.	Page	1
		Page	1 / 1