

Modification	Date	Ed.	2023-03-21	justasabalis
Date	Appr.	Original		
Name	Replaced by	Replacement of		
Project No.	Offer nr.	Page	221.2446.1-PS	1
		Page		1 / 10

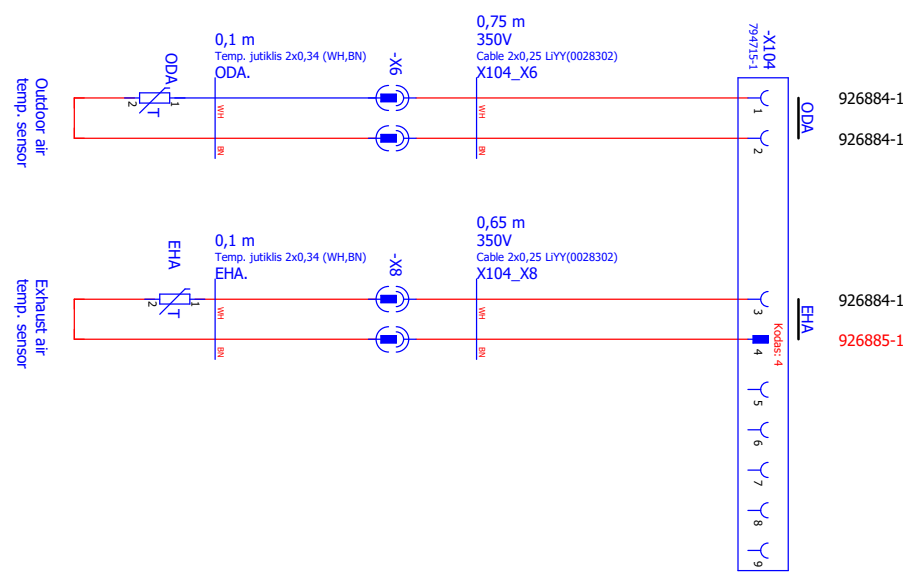

Modification	Date	2023-03-21
Date	Edi.	Justas Sabalis
Name	Appr.	
Original		
Replacement of	Replaced by	
SALDA		
221.2446.2-FS		
Project Nr.	Offer nr.	
= 221.2446		
Page	Page	2
Page	Page	2 / 10

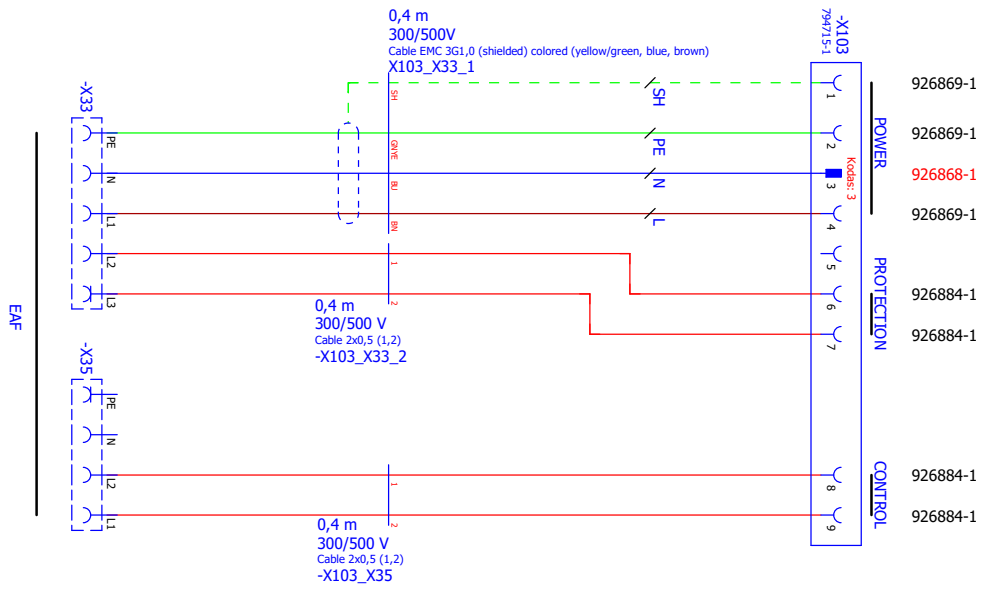
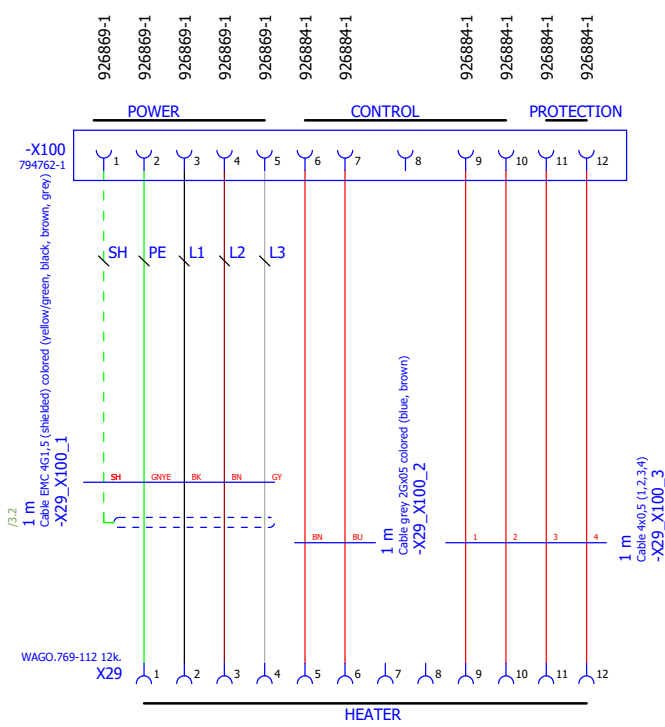

			Date	2023-02-28
			Ed.	justasbalsys
			Appr.	
Modification	Date	Name	Original	Replacement of
				Replaced by



221.2446.3-PS

		= 221.2446	
		+	
Project Nr.	Offer nr.	Page	3
		Page	3 / 10

