



AMBERAIR COMPACT CXP

EN MOUNTING AND INSTALLATION INSTRUCTION



1. CONTENT

1. CONTENT	2
2. SYMBOLS AND MARKING	3
3. SAFETY INSTRUCTIONS AND PRECAUTIONS	4
4. INFORMATION ABOUT THE PRODUCT	5
4.1. DESCRIPTION	5
4.2. DIMENSIONS AND WEIGHT	5
4.3. TECHNICAL DATA	9
4.4. OPERATING CONDITIONS	10
4.5. STANDARD PACKAGE OF COMPONENTS	10
4.6. DESCRIPTION OF COMPONENTS	10
5. INSTALLATION	11
5.1. RECEPTION OF GOODS	11
5.2. TRANSPORTATION AND STORAGE	11
5.3. UNPACKING	12
5.4. PIPING AND INSTRUMENTATION DIAGRAM	13
5.5. MOUNTING	14
5.6. UNIT PLACING AND MOUNTING POSITIONING REQUIREMENTS	15
5.7. CEILING-MOUNTING OF THE UNIT	15
5.7.1. THE INSTALLATION OF THE SUPPORTING LEGS FOR THE FLOOR-MOUNTED VERSION	16
5.7.2. DRAINAGE	16
5.8. CONNECTION OF THE AIR DUCT	17
5.9. CONNECTION OF THE UNIT TO THE ELECTRIC NETWORK	17
5.10. START-UP RECOMMENDATIONS	18
5.10.1. SYSTEM PROTECTION	18
5.10.2. PRE START-UP RECOMMENDATIONS OF THE UNIT (IN THE PRESENCE OF THE END-USER)	18
6. MAINTENANCE	19
6.1. SAFETY INSTRUCTION	19
6.2. GENERAL RECOMMENDATIONS FOR THE MAINTENANCE OF VENTILATION SYSTEM	19
6.3. COVER OPENING	19
6.4. FILTERS MAINTENANCE	21
6.5. FANS MAINTENANCE	21
6.6. HEAT EXCHANGER MAINTENANCE	22
6.7. ELECTRIC, WATER HEATER MAINTENANCE	23
6.8. CONTROL BOARD MAINTENANCE	24
7. CONTROL	25
7.1. DEVICE CONTROL	25
7.2. DEVICE FUNCTIONS	25
8. CONNECTION OF ACCESSORIES	26
8.1. FIRE AND FIREPLACE PROTECTION	26
8.2. EXTERNAL CO ₂ /RH SENSORS	26
8.3. ROOM CO ₂ TRANSMITTER INSTALLATION RECOMMENDATION	26
8.4. CO ₂ CONCENTRATION ACCORDING TO PETTENKOFER LIMIT	26
8.5. CONNECTION OF SUPPLY AND EXHAUST AIR DAMPERS	27
8.6. CONNECTION OF REMOTE CONTROL PANEL OR MODBUS	27
8.7. WATER HEATER CIRCULATION PUMP AND VALVE ACTUATOR	27
8.8. PREHEATER AND COOLER	28
8.9. ELECTRICAL DIAGRAMS AND ABBREVIATION IN ELECTRICAL CIRCUIT DIAGRAMS	28
9. POSSIBLE FAULTS AND TROUBLESHOOTING	33
10. ECODESIGN DATA TABLE	33
11. DECLARATION OF CONFORMITY	34
12. WARRANTY	35
12.1. LIMITED WARRANTY COUPON	35

2. SYMBOLS AND MARKING

 **Warning – pay attention**

 **Additional information**

Apply the technical label on the unit (in an easily accessible location) or on the dashed location of the technical manual to keep the important information about the unit.

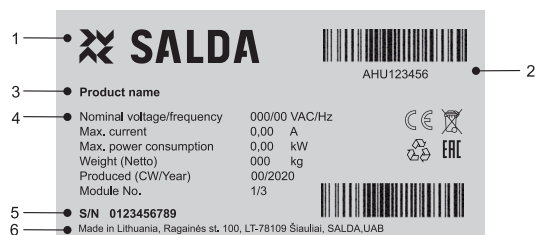

Figure 2.1. Technical label

1 - Logo; 2 - Product code (SKU); 3 - Product name; 4 - Technical data; 5 - Serial number; 6 - Production place.



Figure 2.2. Indication for duct connection.

ODA - outdoor air; SUP - supply air; ETA - extract air; EHA - exhaust air.

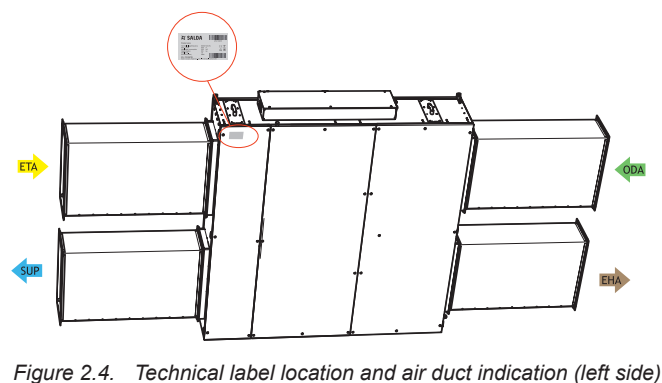
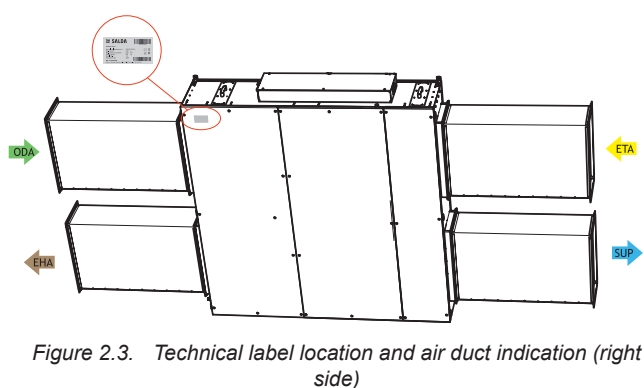

Units tested and produced according to EC directives



SALDA – associated member of the Eurovent association (Europe’s Industry Association for Indoor Climate (HVAC), Process Cooling, and Food Cold Chain Technologies)

VDI 6022

AmberAir Compact SD50+ units designed of the VDI 6022 Part 1 guideline (Hygiene requirements for ventilation and air-conditioning systems and units)

 **NOTE. Ducts are not parts of the unit.**

3. SAFETY INSTRUCTIONS AND PRECAUTIONS

Read these instructions very carefully before installing and using this equipment. Installation, connection and maintenance should be carried out by a qualified technician and in accordance with local regulations and legislation. The company shall take no responsibility for the injuries or damaged property if the safety requirements are not followed, or the device is modified without the permission of the manufacturer.

Main safety rules

Danger



- Before carrying out any electrical or maintenance works, make sure that the device is disconnected from the mains and that all moving parts of the device have stopped.
- Make sure that the fans are not accessible through air ducts or branch openings.
- If any liquids on electric parts or connections that bear voltage are noticed, stop the operation of the device.
- Do not plug the device into the mains that differ from the one indicated on the label or on the housing.
- Voltage of the mains should comply with the electrotechnical parameters indicated on the label.
- The device should be earthed in accordance with the regulations on the installation of electric devices. Turning on and using an un-earthed device is not allowed. Follow the requirements specified on the device's labels that indicate danger.

Warnings



- Connection of electricity and maintenance of the device should be performed by qualified personnel only and in accordance with the manufacturer's instructions and safety requirements.
- In order to reduce the risk during installation and maintenance, suitable protective clothing must be worn.
- Beware of sharp angles while carrying out installation and maintenance works.
- Do not touch heating elements until they haven't cooled down.
- Some devices are heavy, you should be very careful while transporting and installing them. Use suitable lifting equipment.
- When connecting electricity to the mains, a circuit breaker of suitable size must be used.

Warning!



- If the device is installed in a cold environment, make sure that all connections and tubes are properly isolated. Intake and discharge air ducts should be isolated in all cases.
- Openings of the ducts should be covered during transportation and installation.
- Make sure not to damage the heater when connecting the piping of the water heater. For tightening up, use a wrench/spanner.

Before starting up the device



- Make sure, that there are no strange objects inside the device;
- Manually check fans to make sure they are not stuck or blocked;
- If rotary heat exchanger is installed in the device, make sure that it is not stuck or blocked;
- Check the earthing;
- Make sure that all components and accessories are connected in accordance with the wiring diagram or provided instructions.

Danger: Fumes



Salda Antifrost system uses dis-balancing of an airflow and it may cause negative pressure in premises. Care must be taken when using the device in the premises together with another heating appliance that depends on the air in the premises. Such appliances include gas, oil, wood or coal-fired boilers and heaters, fireplaces, continuous flow or other water heaters, gas hobs, cookers or ovens that draw the air in from the room and the duct-exhaust gases out through chimney or extraction ducting. The heating appliance can be starved of oxygen, impairing combustion. In exceptional cases, harmful gases could be drawn out of the chimney or extraction ducting back into the room. In such case we strictly recommend to turn off *Salda Antifrost* and use an external preheater for heat exchanger anti-frost protection (see *Salda Antifrost* function in the Remote Controller Operation Manual).

4. INFORMATION ABOUT THE PRODUCT

4.1. DESCRIPTION

AmberAir Compact CX P includes the following model options:

Model: 1-4 CX P

Model box: CD50.

Heating electric coil: EL1 (low power), EL2 (medium power), EL3 (high power).

Heating water coil: HW1 (low power), HW2 (medium power), HW3 (high power, only for vertical), HW4 (extra high power only for vertical).

Right or left models: R (Right) L (Left). The side where the supply air is located when viewed from the access side.

Fan (plastic/metal impellers): F1 (low power).

Cooling water coil: HW1 (low power), HW2 (medium power). More power capacity available with accessories.

Control type: C1 MCB, C2 Pre-wiring.



Not suitable for operation in pools, saunas and other similar premises.

4.2. DIMENSIONS AND WEIGHT

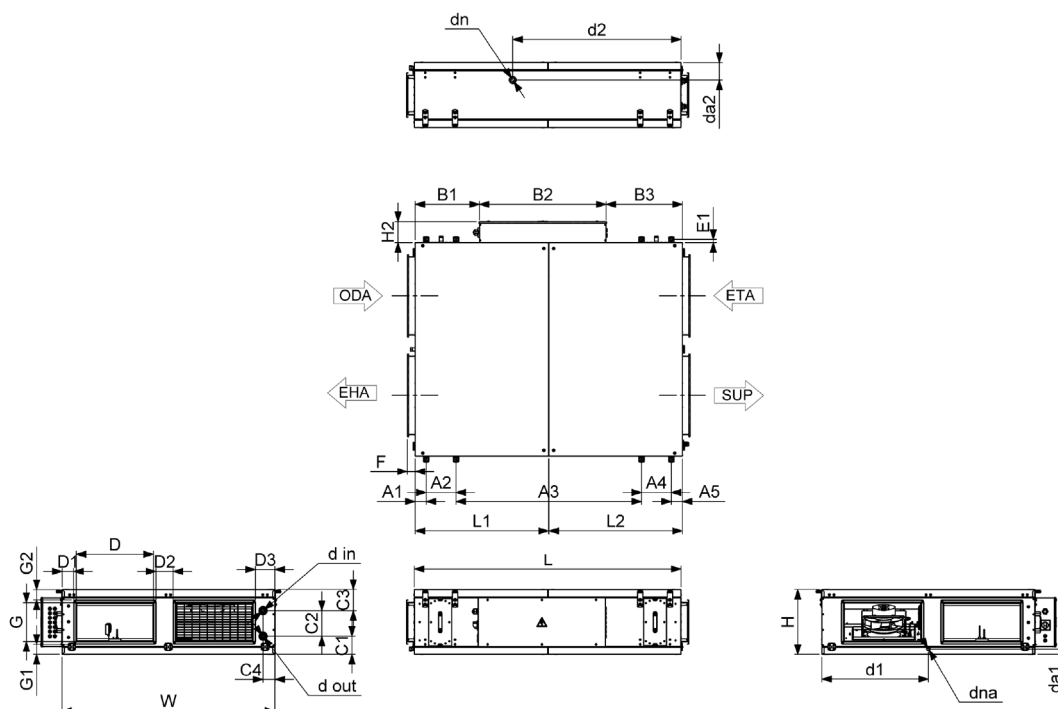

Figure 4.2.1. AmberAir Compact 1 CX P R

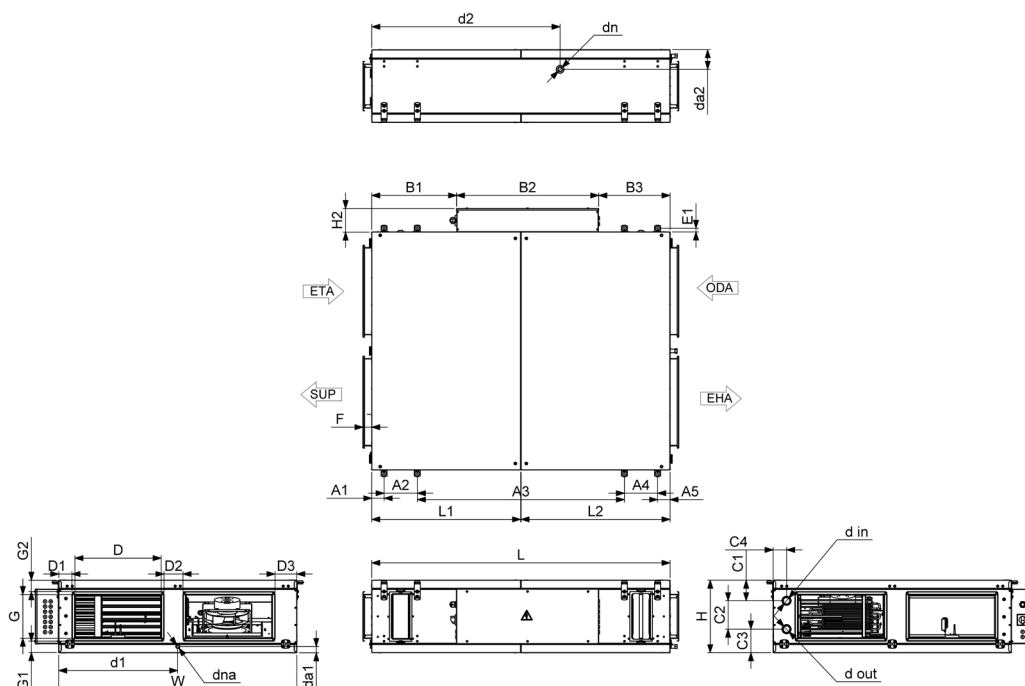

Figure 4.2.2. AmberAir Compact 1 CX P L

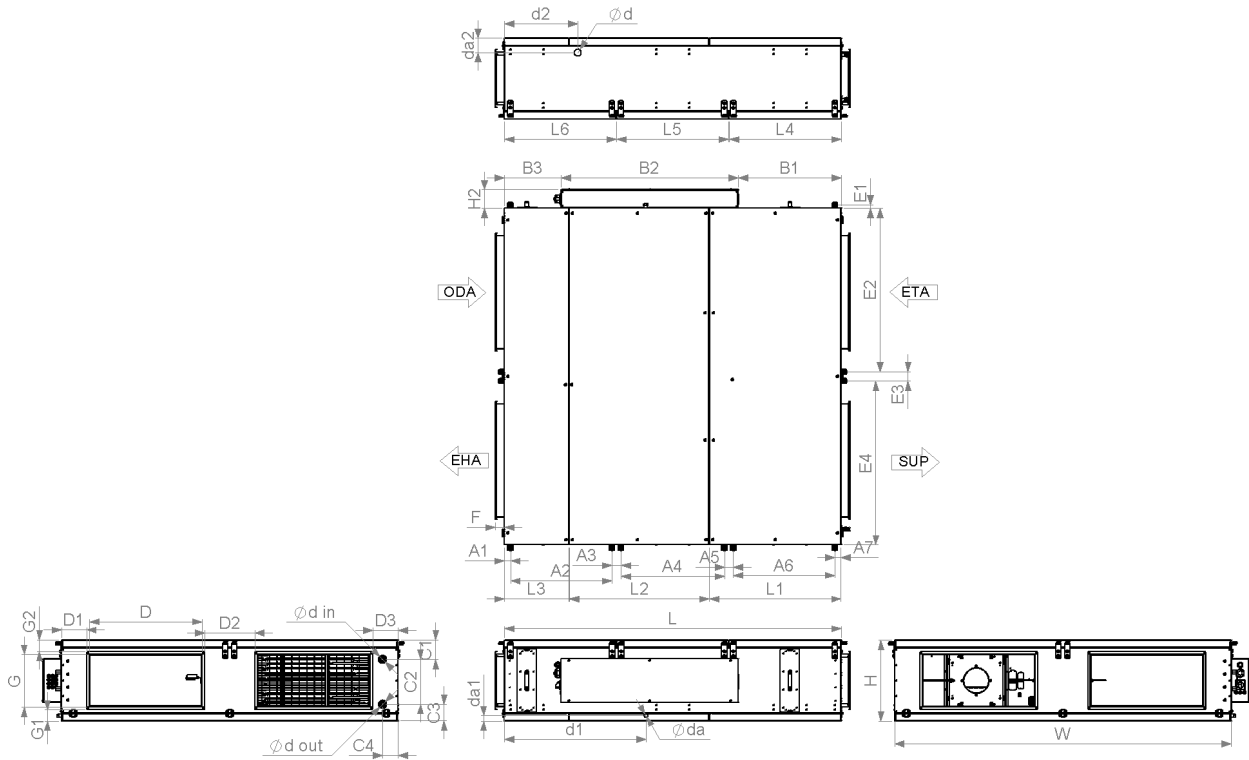

Figure 4.2.3. AmberAir Compact 2-4 CX P R

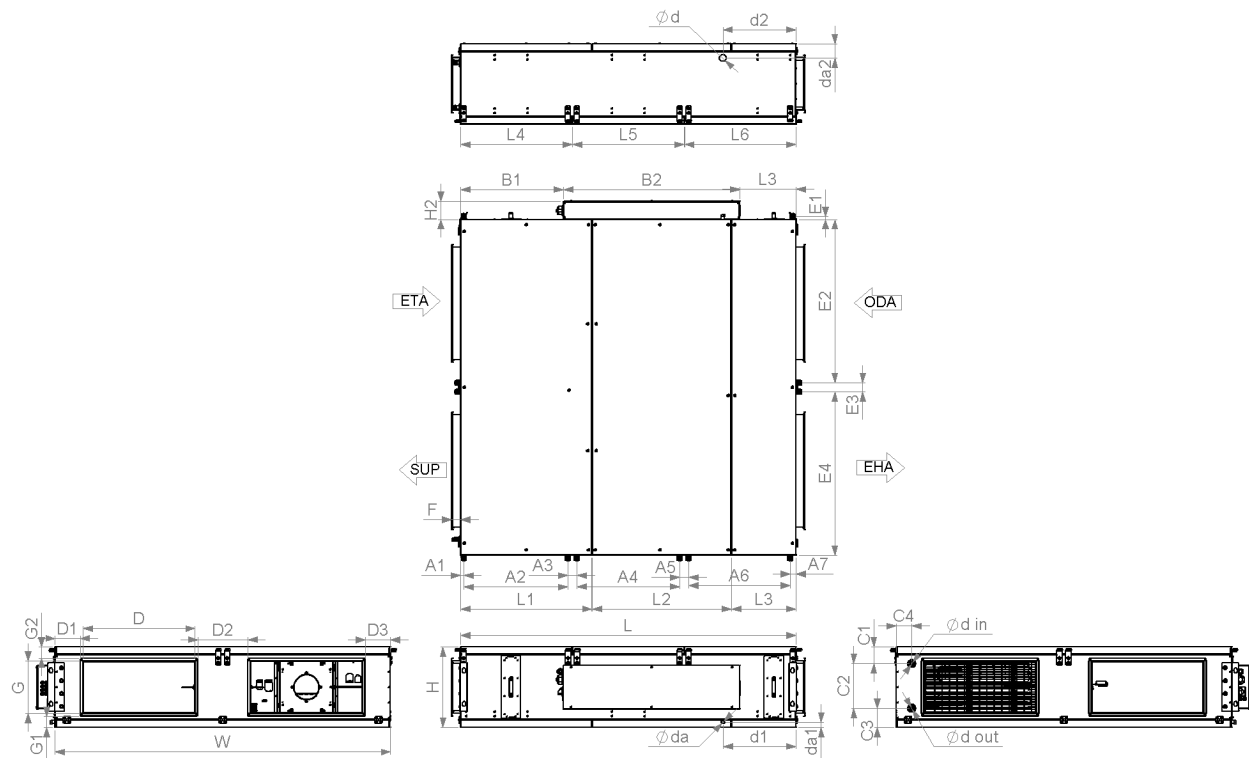

Figure 4.2.4. AmberAir Compact 2-4 CX P L

AMBERAIR COMPACT		1 CX PER	1 CX PWR	1 CX PEL	1 CX PWL	2 CX PER	2 CX PWR	2 CX PEL	2 CX PWL
L	[mm]	1750				1900			
W	[mm]	1397				1850			
H	[mm]	386/426				400/440			
D	[mm]	500				700			
G	[mm]	250				300			
L1	[mm]	874				715			
L2	[mm]	874				812			
L3	[mm]	-				368			
L4	[mm]	-				704			
L5	[mm]	-				595			
L6	[mm]	-				595			
dn						1/2"			
dna						1/2"			
F	[mm]	50				60			
H2	[mm]	138				123			
A1	[mm]	72				61			
A2	[mm]	195				375		363	
A3	[mm]	1215				1038			
A4	[mm]	195				363		375	
A5	[mm]	72				61			
B1	[mm]	498				506		522	
B2	[mm]	835				928			
B3	[mm]	418				464		449	
C1	[mm]	-	101	-	101	-	94	-	94
C2	[mm]	-	167	-	167	-	233	-	233
C3	[mm]	-	118	-	118	-	112	-	112
C4	[mm]	-	78	-	79	-	87	-	87
D1	[mm]	77				124			
D2	[mm]	111				121			
D3	[mm]	127				124			
da1	[mm]	16/36				16/36			
da2	[mm]	95/115				75/95		63/83	
d in		-	1/2"	-	1/2"	-	1/2"	-	1/2"
d out		-	1/2"	-	1/2"	-	1/2"	-	1/2"
E1	[mm]					21			
G1	[mm]	47/67				30/50		30/50	
G2	[mm]	47/67				30/50		30/50	
d1	[mm]	698				817		423	
d2	[mm]	1104				1473		1461	

AMBERAIR COMPACT	1-CXP-I30	1-CXP-I50	1-CXP-E1-I30	1-CXP-E1-I50	1-CXP-E2-I30	1-CXP-E2 I50	1-CXP-W1-I30	1-CXP-W1-I50	1-CXP-W2-I30	1-CXP-W2-I50	1-CXP-W3-I50
Weight [kg]	188	197	192	197	193	198	194	199	196	201	203

AMBERAIR COMPACT	2-CXP-I30	2-CXP-I50	2-CXP-E1-I30	2-CXP-E1-I50	2-CXP-E2-I30	2-CXP-E2 I50	2-CXP-W1-I30	2-CXP-W1-I50	2-CXP-W2-I30	2-CXP-W2-I50	2-CXP-W3-I50
Weight [kg]	273	262	280	288	282	290	280	288	281	289	290

AMBERAIR COMPACT		3 CX PER	3 CX PWR	3 CX PEL	3 CX PWL	4 CX PER	4 CX PWR	4 CX PEL	4 CX PWL
L	[mm]	1950				2250			
W	[mm]	2060				2250			
H	[mm]	400/440				500/540			
D	[mm]	750							
G	[mm]	300				350			
L1	[mm]	765				879			
L2	[mm]	813				932			
L3	[mm]	367				433			
L4	[mm]	729				748			
L5	[mm]	608				748			
L6	[mm]	608				748			
Ød		1/2"				-			
Øda		1/2"				-			
Ød	[mm]	-				21			
Øda	[mm]	-				21			
F	[mm]	60				60			
H2	[mm]	125				122			
A1	[mm]	61				41		21	
A2	[mm]	367				678		699	
A3	[mm]	1092				60			
A4	[mm]	367				691			
A5	[mm]	61				60			
A6	[mm]	-				678		682	
A7	[mm]	-				38	40/41		38
B1	[mm]	571				688			
B2	[mm]	928				1185			
B3	[mm]	449				377			
C1	[mm]	-	75/95	-	75/95	-	128	-	112
C2	[mm]	-	233	-	233	-	300	-	300
C3	[mm]	-	91/111	-	91/111	-	110	-	127
C4	[mm]	-	88	-	88	-	104	-	104
D1	[mm]	140				169			
D2	[mm]	200				333			
D3	[mm]	140				169			
da1	[mm]	16/36				36			
da2	[mm]	64/84				96			
Ød in		-	22	-	22	-	22	-	22
Ød out		-	22	-	22	-	22	-	22
E1	[mm]	21							
E2	[mm]	-				1095			
E3	[mm]	-				60			
E4	[mm]	-				1095			
G1	[mm]	30/50				75			
G2	[mm]	30/50				75			
d1	[mm]	838		423		945		490	
d2	[mm]	427				490		490	

AMBERAIR COMPACT	3-CXP-I30	3-CXP-I50	3-CXP-E1-I30	3-CXP-E1-I50	3-CXP-E2-I30	3-CXP-E2-I50	3-CXP-W1-I30	3-CXP-W1-I50	3-CXP-W2-I30	3-CXP-W2-I50	3-CXP-W3-I50
Weight [kg]	305	315	377	387	380	390	377	387	378	388	389
AMBERAIR COMPACT	4-CXP-I30	4-CXP-I50	4-CXP-E1-I30	4-CXP-E1-I50	4-CXP-E2-I30	4-CXP-E2-I50	4-CXP-W1-I30	4-CXP-W1-I50	4-CXP-W2-I30	4-CXP-W2-I50	4-CXP-W3-I50
Weight [kg]	437	433	440	451	444	455	439	450	440	451	452

4.3. TECHNICAL DATA

CX P units can be integrated with various selected components.

AMBERAIR COMPACT		1 CX P				2 CX P			
Exhaust air fan		F1				F1			
phase/voltage	[50 Hz/VAC]	1/230				1/230			
power/current	[kW/A]	0,38/2,5				0,39/1,7			
speed	[min ⁻¹]	3370				3530			
control input	[VDC]	0-10				0-10			
protection class		IP54				IP54			
Supply air fan		F1				F1			
phase/voltage	[50 Hz/VAC]	1/230				1/230			
power/current	[kW/A]	0,38/2,5				0,39/1,7			
speed	[min ⁻¹]	3370				3530			
control input	[VDC]	0-10				0-10			
protection class		IP54				IP54			
Electrical heater		E1	E2	E3	E4	E1	E2	E3	E4
Power	[kW]	2	3,6	2	3,6	3	6	3	6
Insulation of walls	[mm]	30/50				30/50			
Exhaust air filter (class, dimensions LxWxH)	[mm]	ePM1-70, 645x256x90				ePM10-55, 894x279x46			
Supply air filter (class, dimensions LxWxH)	[mm]	ePM1-70, 645x256x90				ePM1-70, 894x279x46			

AMBERAIR COMPACT		3 CX P				4 CX P			
Exhaust air fan		F1				F1			
phase/voltage	[50 Hz/VAC]	3/400				3/400			
power/current	[kW/A]	1,05/1,6				1,8/2,8			
speed	[min ⁻¹]	3400				3410			
control input	[VDC]	0-10				0-10			
protection class		IP55				IP54			
Supply air fan		F1				F1			
phase/voltage	[50 Hz/VAC]	3/400				3/400			
power/current	[kW/A]	1,05/1,6				1,8/2,8			
speed	[min ⁻¹]	3400				3410			
control input	[VDC]	0-10				0-10			
protection class		IP55				IP54			
Electrical heater		E1	E2	E3	E4	E1	E2	E3	E4
Power	[kW]	4,5	9	3,6	9	6	12	6	9
Insulation of walls	[mm]	30/50				30/50			
Exhaust air filter (class, dimensions LxWxH)	[mm]	ePM1-70, 1000x279x46				ePM1-70, 1113x379x46			
Supply air filter (class, dimensions LxWxH)	[mm]	ePM10-55, 1000x279x46				ePM10-55, 1113x379x46			

According to EN 13141-7.

Acoustic data: check the product page on www.salda.it

Control board with complete set of MCB controllers is integrated in all CX P units.
List of possible fans and electrical heaters of the unit is present above. More details of the unit and each unit's component can be found on the "VentMaster" selection app.

Not suitable for installation in living rooms: additional noise insulation required.

4.4. OPERATING CONDITIONS

AMBERAIR COMPACT	1 CX P	2 CX P	3 CX P	4 CX P
Minimum outdoor air temperature	-23 °C	-23 °C	-23 °C	-23 °C
Maximum outdoor air temperature	40 °C	40 °C	40 °C	40 °C
Minimum extracted air temperature	15 °C	15 °C	15 °C	15 °C
Maximum extracted air temperature	40 °C	40 °C	40 °C	40 °C
Maximum extracted air relative humidity	60 %	60 %	60 %	60 %
Minimum ambient air temperature	-23 °C*	-23 °C*	-23 °C*	-23 °C*
Maximum ambient air temperature	40 °C	40 °C	40 °C	40 °C
Installation	indoor/outdoor	indoor/outdoor	indoor/outdoor	indoor/outdoor

* - with 50 mm insulation.

4.5. STANDARD PACKAGE OF COMPONENTS

AMBERAIR COMPACT	1 CX P	2 CX P	3 CX P	4 CX P
Key	1	1	1	1
Supply air temperature sensor TJ	1	1	1	1
Water temperature sensor for water heater TV1 (water version only)	1	1	1	1
Hanging bracket	8	8	8	16
Anti-vibration rubber	8	8	8	16
Legs for ground version	2	3	3	3
Legs for vertical version	2	3	3	3

4.6. DESCRIPTION OF COMPONENTS

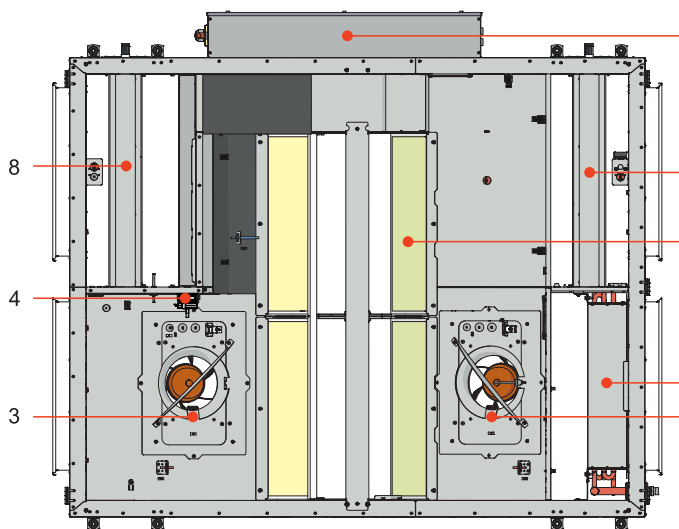

Figure 4.1. AmberAir Compact 1 CXP

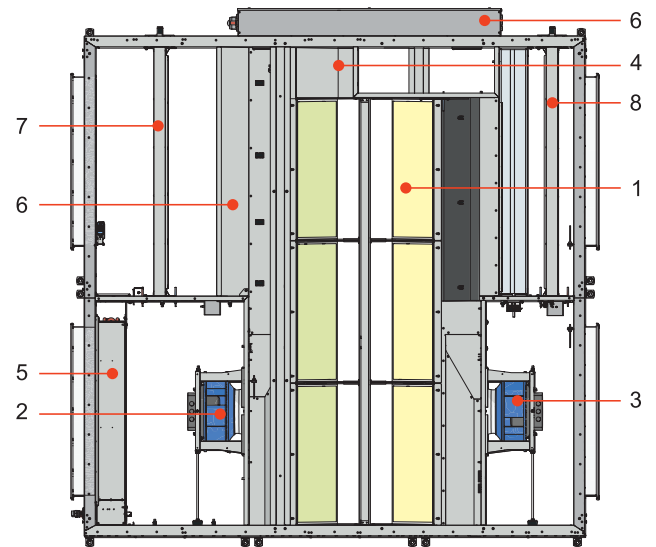

Figure 4.2. AmberAir Compact 2-4 CXP

1 - Plate heat exchanger; 2 - Supply fan; 3 - Exhaust fan; 4 - By-pass damper; 5 - Heating coil (depends on the model); 6 - Control board; 7 - Extract air filters (panel); 8 - Supply air filter (panel).

5. INSTALLATION

5.1. RECEPTION OF GOODS

Each device is carefully checked before transportation. When receiving the goods, checking the devices for any damage made during transportation is recommended. If any damage to the unit is observed, immediately contact the representatives of a transport company. Please inform the representative of the manufacturer, if any deviation of the device is noticed.

5.2. TRANSPORTATION AND STORAGE

- All units are factory-packaged to withstand normal conditions of transportation.
- When unpacking, check the unit for any damage made during transportation. Installing the damaged units is not allowed!
- **The packaging is used for protection purposes only!**
- When unloading and storing the units, use suitable lifting equipment to avoid damage and injuries. Do not lift units by holding on power supply cables, connection boxes, air extract or exhaust flanges. Avoid hits and shock overloads. Before installation, the units must be stored in a dry room with relative air humidity not exceeding 70 % (at +20 °C) and with an average ambient temperature ranging between +5 °C and +30 °C. The storage place must be protected against dirt and water.
- The units must be transported to the storage place or installation site using forklifts.
- The recommended storage period should not be longer than one year. In case of storing the units for a period longer than one year, checking if the fan bearings and motor rotate without difficulty (turning the impeller by hand) and if the electric circuit insulation is not damaged or the moisture has not accumulated must be performed before the installation of the unit.



The product is heavy. Exercise caution when transporting and installing.

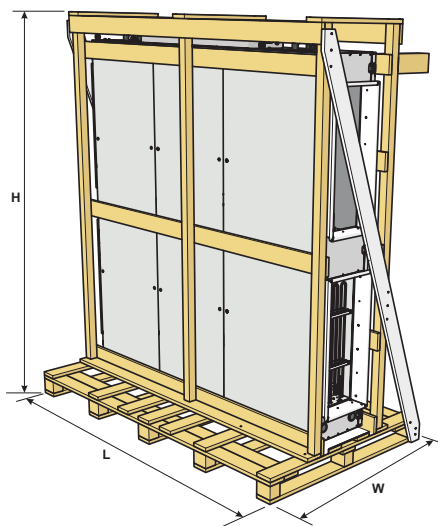

AMBERAIR COMPACT	H [mm]	W [mm]	L [mm]
1 CX P	1707	1000	1900
2 CX P	2166	1200	2050
3 CX P	2398	1200	2164
4 CX P	2578	1200	2464

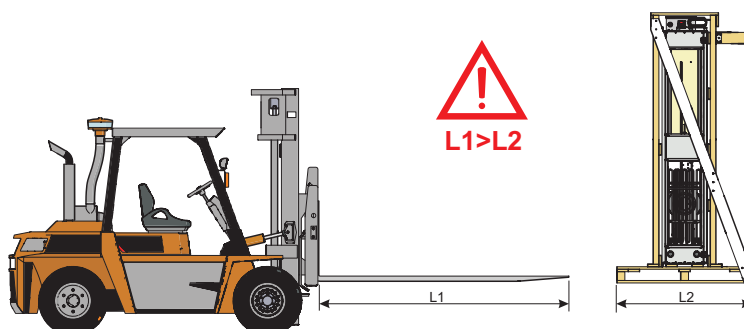

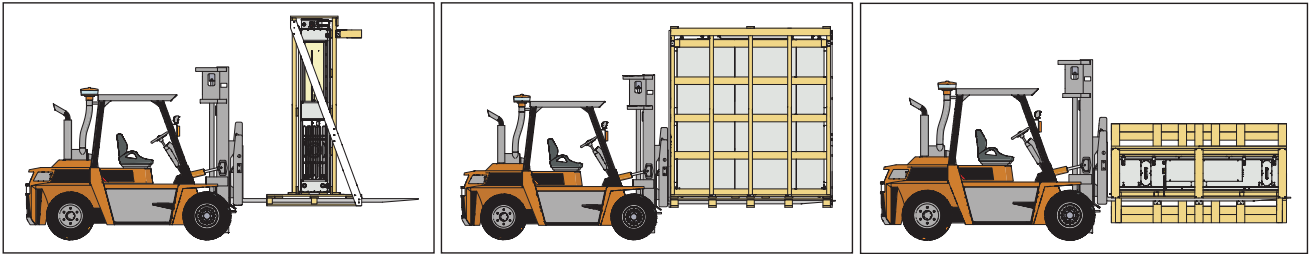

Figure 5.2.1. AmberAir Compact CX P lifting with a forklift

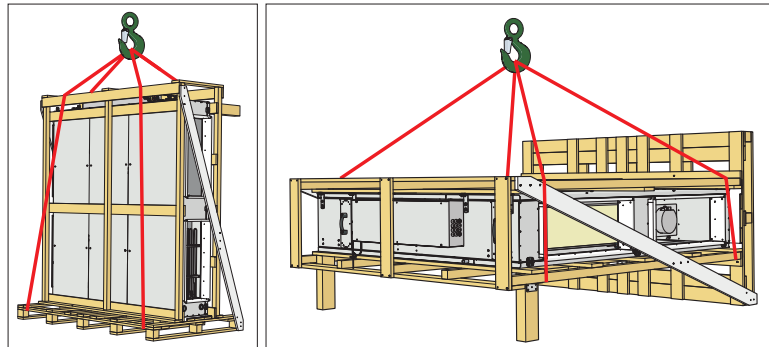

Figure 5.2.2. AmberAir Compact CX P lifting with slings

⚠ In order to prevent damage to the casing, only a product placed on a pallet should be lifted.

5.3. UNPACKING

⚠ Accessories may be packed together with the product. Prior to transporting the unit, the accessories should be unpacked first.

⚠ AmberAir Compact CX P are very heavy, so exercise caution when handling them. Follow safety requirements established in your country.

- Remove the film from the unit.
- Remove the bracing packaging tape that keeps the protective profiles in place.
- Remove the protective profiles.
- After unpacking the unit, examine it to make sure that no damage was made during transportation. Installation of damaged units is not allowed!
- Before commencing the installation of the unit, please check if all ordered equipment has been delivered. Any deviation from the ordered equipment list must be reported to the product supplier.

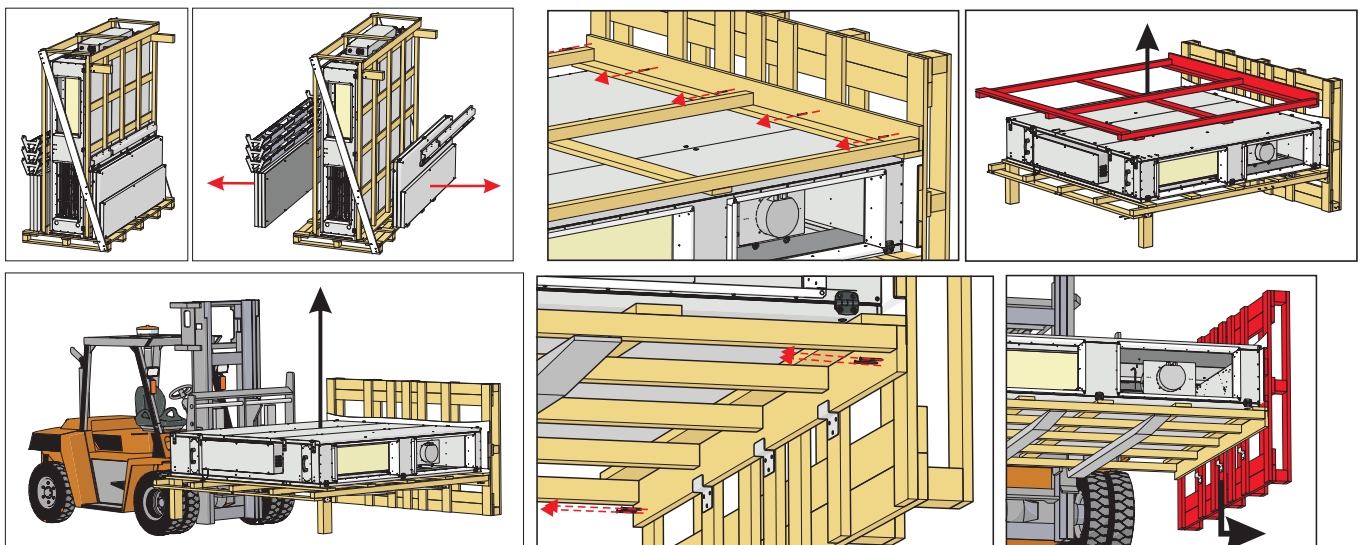

⚠ After unpacking AmberAir Compact 4 CX P, open the side covers and unscrew the supporting legs, which are used for transportation, from the fans.

5.4. PIPING AND INSTRUMENTATION DIAGRAM

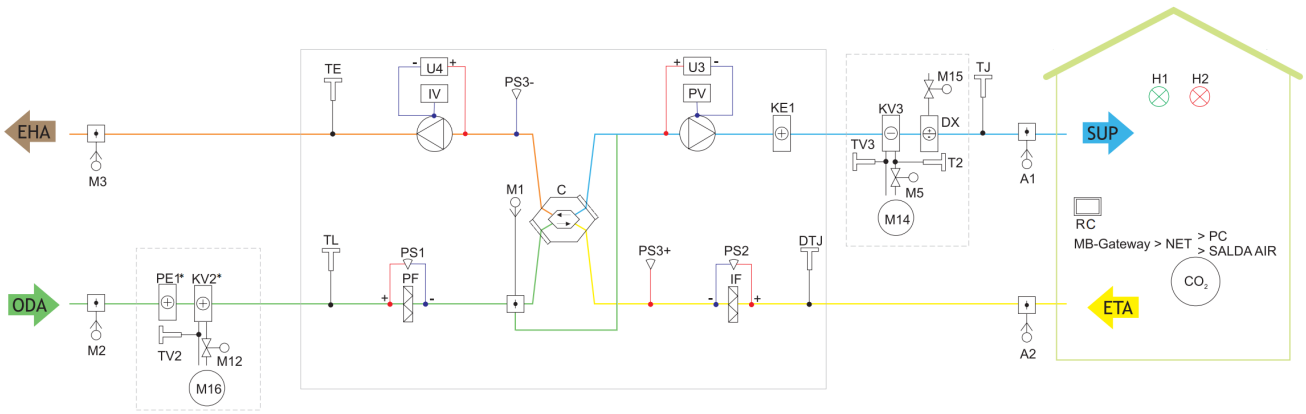

Figure 5.4.1. Electrical version

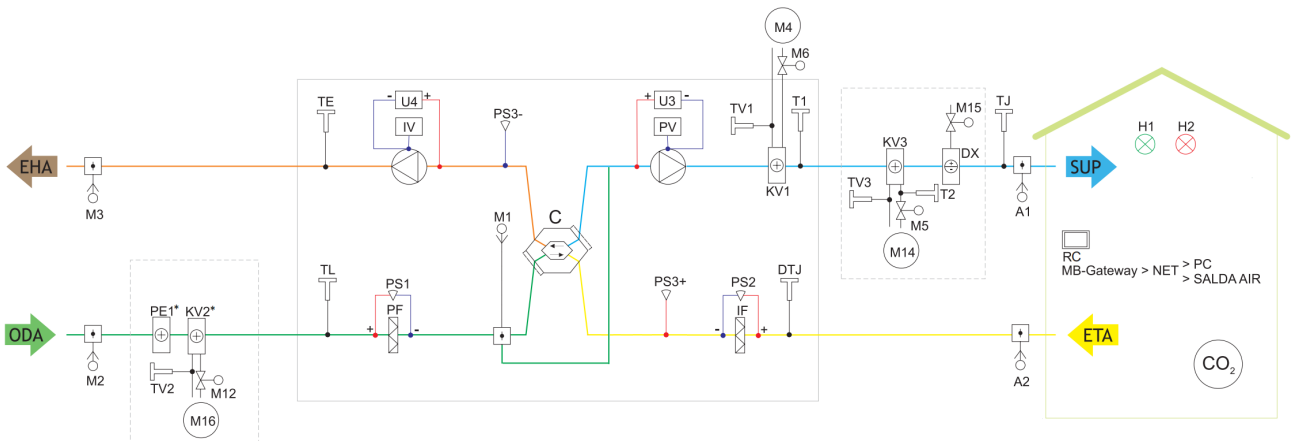

Figure 5.4.2. Water version

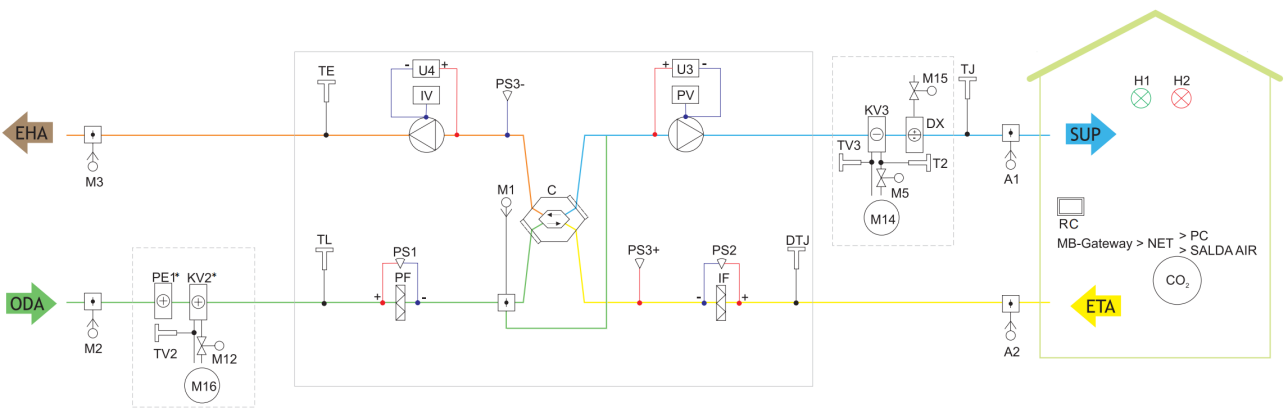



Figure 5.4.3. Without integrated coil version

* The electric and water pre-heaters may not be used at the same time.

LIST OF COMPONENTS

C	Plate heat exchanger	PV	Supply air fan
IF	Extract air filter	PF	Supply air filter
IV	Exhaust fan	TE	Exhaust air temperature sensor
TJ	Supply air temperature sensor	DTJ	Extract air temperature and humidity sensor
CO₂	CO ₂ sensor	PC	Computer
KE1	Electric heater	PE1	Electric pre-heater
M1	By-pass damper actuator	M2	Outdoor air damper actuator
M3	Exhaust air damper actuator	A1	Fire alarm damper actuator I
A2	Fire alarm damper actuator II	U3	Supply air fan pressure sensor
U4	Exhaust air fan pressure sensor	TL	Outdoor air temperature sensor
	Ventilated premises	MB-Gateway	Network module
NET	Network	RC	Stouch or ST-SA-Control remote control panel
DX	DX cooler	KV1	Water heater
KV2	Water pre-heater	KV3	Water cooler
T1	Water heater thermostat	T2	Cooler switching thermostat
M4	Water heater circulation pump	M16	Water pre-heater circulation pump
M14	Water cooler circulation pump	M5	Water cooler valve motor
M12	Water pre-heater valve motor	M15	DX cooler valve motor
M6	Water heater valve motor	TV1	Water heater temperature sensor
TV2	Water preheater temperature sensor	TV3	Water cooler temperature sensor
PS1	Supply air filter differential pressure sensor	PS2	Extract air filter differential pressure sensor
PS3	Heat exchanger differential pressure sensor		

POSSIBLE PCB INPUTS/OUTPUTS

FA	Fire alarm	FPP	Fireplace protection
H1	Working indication output	H2	Alarm indication output
	System mode switch (START/STOP)		Fans speed switch (BOOST)

5.5. MOUNTING

- Installation works should be carried out by qualified and trained staff only.
- When connecting air ducts, consider the labels on the casing of the unit.
- Before connecting to the air duct system, the connection openings of the ventilation unit should be closed.
- When connecting the ducts, the air-flow direction indicated on the device housing should be observed.
- Do not connect the bends close to the connection flanges of the unit. The minimum distance of the straight air duct between the unit and the first branch of the air duct in the supply and exhaust air ducts must be 3xD, where D is the diameter of the air duct.
- It is recommended to use the brackets (accessories). This will reduce the vibration transmitted by the unit to the air duct system and environment.
- Sufficient space must be provided for opening the device door and filter covers.
- If the ventilation unit is a wall-mounted device, it may transmit noise vibrations to the premises. Though the level of noise generated by the fans is admissible, we recommend mounting the unit at a distance of 400 mm from the nearest wall. Where this is not possible, we recommend mounting the unit on the wall of the room where the level of noise is not significant.
- Ducts are connected to the unit in such a way that they could be easily disassembled, and the coil could be removed from the unit when carrying out maintenance, service and/or repair works.

 **The protective film is used to protect the unit during transportation. It is recommended to remove the film; otherwise, oxidation signs may occur.**

 **The condensate tube must be filled with water as indicated during the first start-up before every heating season!**

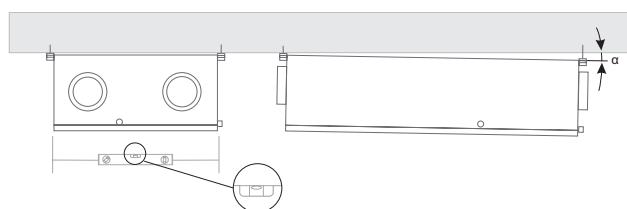

Figure 5.5.1. Ceiling-mounting positions ($\alpha > 1^\circ$)

The product can be installed under the ceiling or on the floor.

Installation under the ceiling

- When installing under the ceiling, the product is screwed up to the supporting legs with shock-absorbing gaskets.
- The method of raising the product is shown in the section **"TRANSPORTATION AND STORAGE"**.
- AmberAir Compact 1 CX P is installed straight using a level. AmberAir Compact 2-4 CX P should be turned by 0.5-1°.

Installation on the floor

- When installing on the floor, the second supporting legs attached by the manufacturer should be used.
- The installation of the base is shown on *page 16*.
- AmberAir Compact 1 CX P is installed after alignment using a level.
- AmberAir Compact 2-4 CX P is installed with its end raised by 0.5-1°.

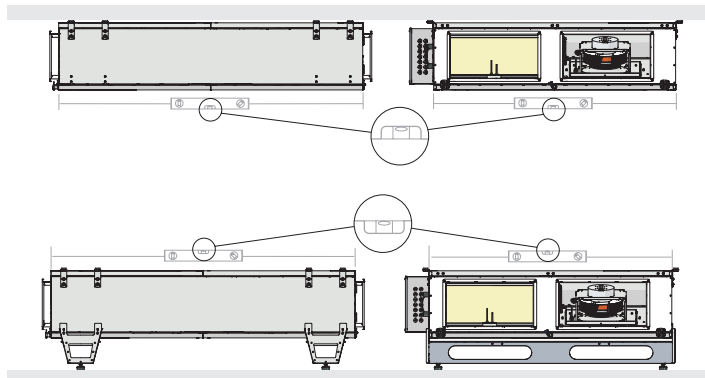

Figure 5.5.2. AmberAir Compact CX P mounting

5.6. UNIT PLACING AND MOUNTING POSITIONING REQUIREMENTS

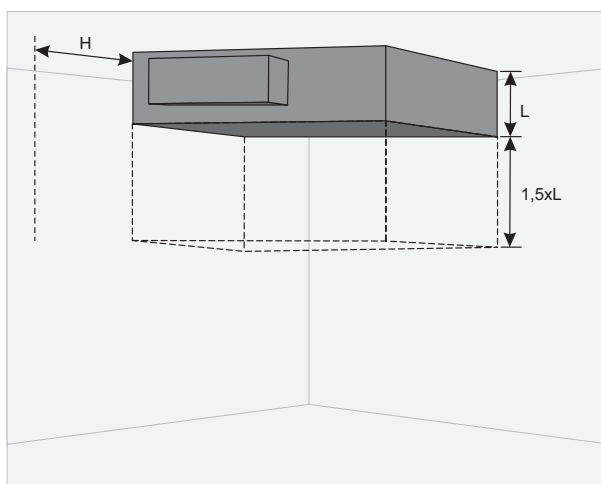
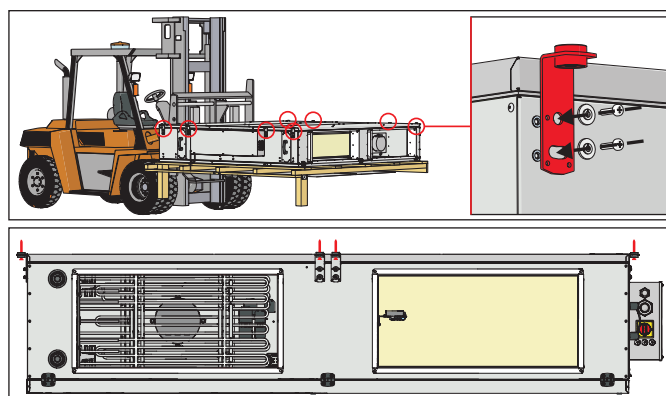

Figure 5.6.1. Min. distance to open the door - 1,5xL; Min. distance to open the control box door - $H > 400$ mm.

5.7. CEILING-MOUNTING OF THE UNIT

- Before starting installation work, first unpack the product as shown in the section **"UNPACKING"**.
- After screwing up the suspension brackets, the product with the whole remaining pallet is raised to the ceiling using a forklift.
- After mounting the product to the wall, the forklift with the remaining pallet is withdrawn.



- Rails are offered as an accessory to be screwed up to the suspended product after installing the cover holders to the appropriate position.
- If the thickness of the cover is 30 mm, insert the holder into the upper hole. If the thickness of the cover is 50 mm, insert the holder into the lower hole.
- To screw up the rails, washers and screws are used.
- When using the rails, the hinges should be unscrewed from the cover after screwing up its ends. The accessories bag contains screws for fastening the end of the cover that was previously held by the hinges.

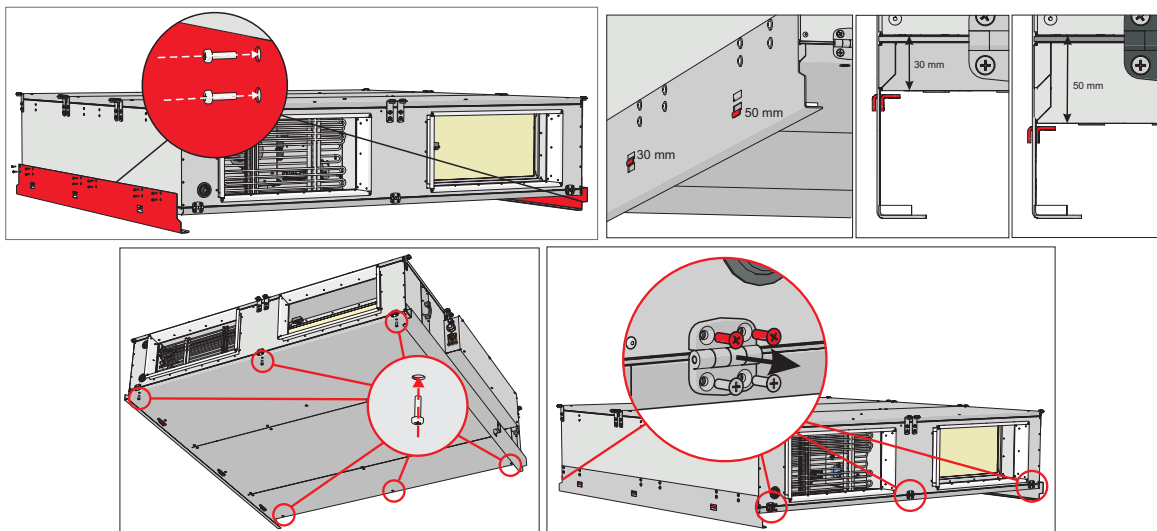

5.7.1. THE INSTALLATION OF THE SUPPORTING LEGS FOR THE FLOOR-MOUNTED VERSION

- Before starting installation work, first unpack the product as shown in the section **"UNPACKING"**.
- After screwing up 4 lifting brackets to the product, fasten the lifting slings to the brackets (use washers and screws for screwing up).
- Using a crane, lift the product by not more than 50 cm (as high as sufficient to put the supporting legs under the product).
- The legs are screwed up taking into account the cover thickness (30 mm or 50 mm).

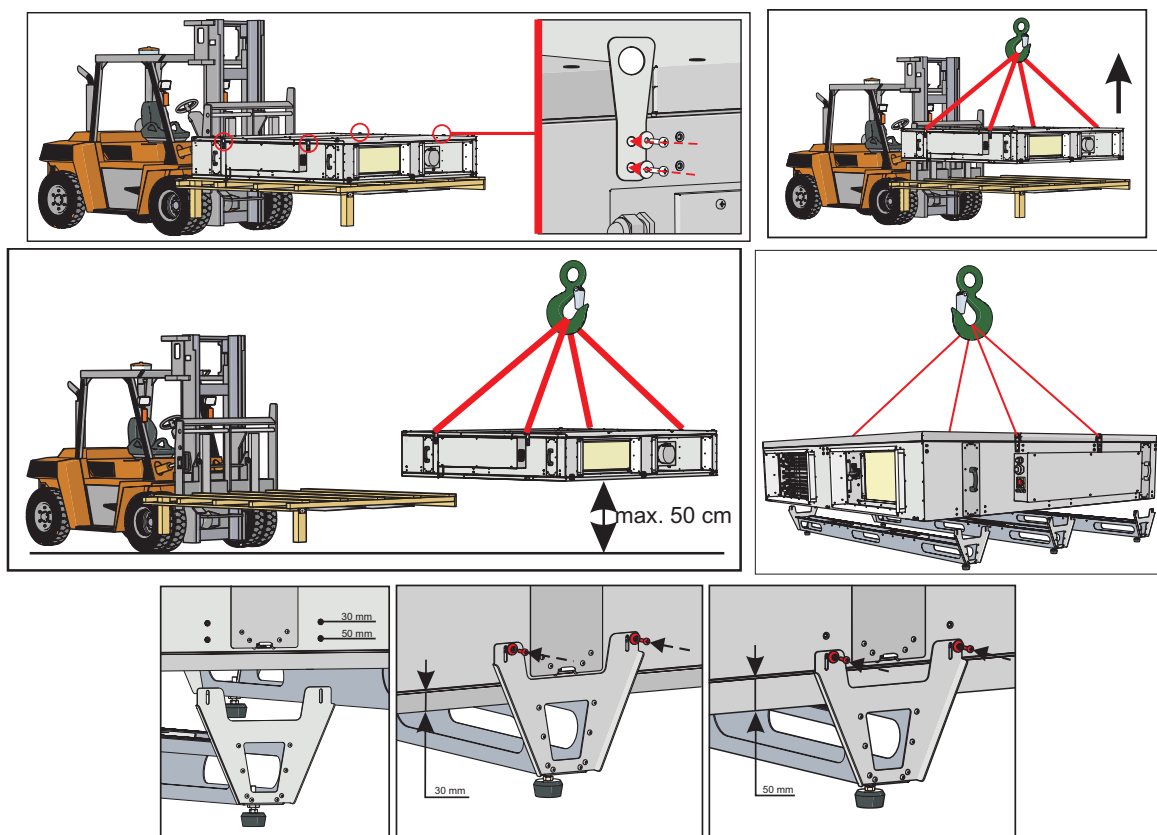

5.7.2. DRAINAGE

- After installing the air unit, the condensate drainage system should be connected: screw up the hose (3) with the attached fastener (2) to the condensate trap (1) of the heat recovery unit, insert the hose into the siphon (4) (shown at the bottom of the picture).
- The siphon (4) is connected with the sewage system via a pipe (5).
- It should have a gradient of at least 3° (a meter of the pipe should descend by min 55 mm)!

- Prior to starting the recovery unit, the drainage system should be filled with 0.5 litre or more water (the siphon (4) should always be filled up) and verify that water flows to the sewage system)!
- Otherwise, the room may be flooded when operating the recovery unit!
- The condensate drainage system should be operated on the premises with an ambient temperature above 0 °C to prevent freezing!
- Otherwise, the drainage system must be insulated and must be provided with a heating cable and thermostat!
- The siphon (4) should not necessarily be downstream the recovery unit but below it.

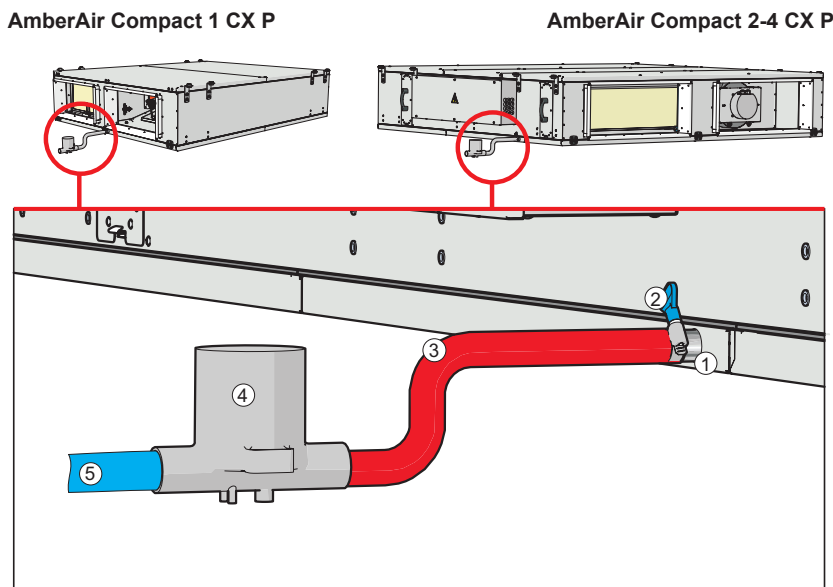

⚠ The condensate tube must be filled with water as indicated during the first start-up before every heating season!

5.8. CONNECTION OF THE AIR DUCT

- The connected air ducts must not be bent and must be fixed separately.
- Make sure that the fans may not be accessed through air duct heads. Otherwise, a protective grid should be installed. You may choose the grid from the range of products provided on our website <https://select.salda.it>.
- Do not reduce the diameter of the piping near the air inlet or exhaust ducts. If you want to reduce the airflow speed in the system, also to reduce pressure and noise level, you can increase the diameter.
- In order to reduce the level of noise in the air supply system, install silencers (see the chapter on air supply system installation).
- In order to reduce air loss in the system, the air ducts and profile components should be of class C or higher. The catalogue of the above-mentioned items can be found on our website <https://select.salda.it>.
- External air and exhaust system piping should be isolated in order to prevent heat loss and condensation.
- We recommend to maintain a distance of up to 8 meters between air intake and air exhaust ducts. The air intake point should be installed away from potential air pollution sources.
- When installing air ducts next to the ventilation equipment, brackets must be used. They suppress vibration and assure secure installation of the various system parts. The necessary brackets can be found in our catalogue or on our website <https://select.salda.it>.
- Air ducts are often mistakenly connected in an inappropriate location. The ventilation units bear the labels indicating the correct air duct connection layout. Before starting up the system, carefully check if all related works have been performed properly.

⚠ For flange diameters see chapter "DIMENSIONS AND WEIGHT".

5.9. CONNECTION OF THE UNIT TO THE ELECTRIC NETWORK

- Supply voltage to the unit must be connected by a qualified specialist following the manufacturer's instructions and applicable safety guidelines.
- The unit's power network voltage must correspond to the electro-technical specifications of the unit indicated in the technical decal.
- The unit's voltage, power and other technical specifications are provided in the unit's technical decal (on the unit casing). The unit must be connected to the grounded power network in accordance with the applicable requirements.
- The unit must be earthed according to electrical equipment installation regulations.
- Using extension wires (cables) and power network plug socket distribution devices is not allowed.
- Prior to carrying out any ventilation unit installation and connection works (before the unit is commissioned), the unit must be disconnected from the power network.
- After installation of the ventilation unit, the power network plug socket must be accessible at any time and disconnection from the power network must be performed through the circuit breaker (by disconnecting phase poles and neutral).
- Before it is connected to the power network, the unit must be carefully checked for any damage (operation, control, and measurement nodes) made during transportation.
- The power cable can be replaced only by a qualified technician, having evaluated the rated power and current.
- First connect power cable to the unit, then connect to the power source.

Connecting cable to the unit:

- Unscrew and remove the control box cover (see figure in **"CONTROL BOARD MAINTENANCE"** section).
- Route power cable from the outside of the unit to the inside of the control box through the plastic cable gland near the main switch.
- Connect securely power cable wires to the main switch Q1 inside of the control box. Connection depends on the electro-technical specifications of the exact unit.

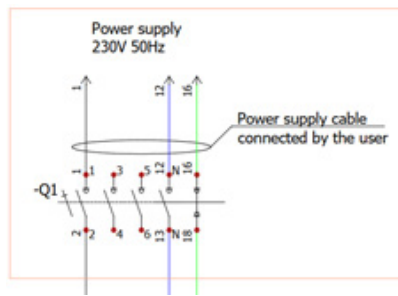

Figure 5.9.1. Units with 1N~ 230VAC power supply

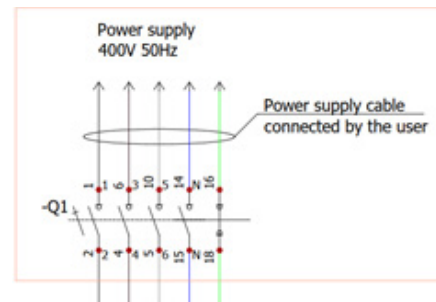

Figure 5.9.2. Units with 3N~ 400VAC power supply

- Install back control box cover.



The manufacturer does not assume any liability for personal injuries and property damage due to non-conformance with the provided instructions.

5.10. START-UP RECOMMENDATIONS

5.10.1. SYSTEM PROTECTION

The controller boards of the unit is equipped with integrated protection devices (fuses). Most of the fuses are default (max.) value. These values can be found on MCB technical manual. However, for some units MCB EX2 controller board fuses are lower than default (max.) value:

MCB EX2 Fuse	UNIT TYPE		
	All 4-CX-P units	3-CX-P with electric heater	2-CX-P with electric heater
F1	2A	0,5A	2A
F2	-	-	2A
F4	-	0,5A	-

It is recommended to use the unit with an external electrical protection device. Protection device must be selected and installed by qualified specialist. Nominal values of the device depends on exact unit. For protection device selection follow unit's technical information on technical label or "VentMaster" selection app.



To ensure safe maintenance of the unit, it is necessary to turn off the main switch and/or external protection device.

5.10.2. PRE START-UP RECOMMENDATIONS OF THE UNIT (IN THE PRESENCE OF THE END-USER)

Prior to start-up, the system must be carefully cleaned. Check for the following:

- Operation systems and unit elements as well as automation and automation devices were not damaged during installation,
- All electrical devices are connected to power supply and fit for service,
- All necessary automation elements are installed and connected to power supply and MCB, EX1, EX2 terminal blocks,
- Cable/wire connection to MCB, EX1, EX2 terminal blocks comply with the existing power connection diagrams,
- All electrical equipment protection components are properly connected (if they are additionally used),
- Cables and wires correspond to all applicable safety and functional requirements, diameters, etc.,
- Earthing and protection systems are properly installed,
- Condition of all seals and sealing surfaces is proper.

6. MAINTENANCE

6.1. SAFETY INSTRUCTION



Unplug the unit from the mains before opening the door (disconnect the power plug from the outlet or in case an automatic circuit breaker is installed, disconnect it as well. Make sure that it cannot be turned on by the third parties) and wait until the fans completely stop (for about 2 min.).

6.2. GENERAL RECOMMENDATIONS FOR THE MAINTENANCE OF VENTILATION SYSTEM

In order to ensure the proper functioning of the system, maintenance requirements and its periods should be observed. Otherwise, the warranty shall be void. Some recommendations are provided in the table below, but they are just advisory, as the need for system maintenance depends on the location of the unit installation, the pollution of the atmosphere, population, working hours, etc.

COMPONENT	DURING START-UP	AT LEAST EVERY 6 MONTHS
Filters	Check the cleanliness of the filters	Replace filters every 3 to 4 months or according to the control device indications. Make sure that the pressure relay/transmitter is clean and clean it if necessary. Check for any damaged filter fastening parts.
Fans	Check the connections and the direction of rotation	Check cleanliness. Clean, if necessary. Make sure that the impellers are not unbalanced. Make sure that the impellers do not cause noise when rotated by hand. Make sure that the fastening screws are not loose and free of mechanical damage. Check electrical connections and make sure that these are secured properly and are free of signs of corrosion.
Plate Heat exchanger	Check the cleanliness of the heat exchanger	Check cleanliness and clean, if necessary.
Control panel	Check the connections	Check the connections.
Electric heater	Check the connections	Clean off dust, and check the electrical components and connections of the heater.
Water heater	Check the tightness	Check cleanliness and clean, if necessary. Check the tightness and seal the connections, if necessary.
Condensate discharge trap		Clean.
Pressure sensor	Check electrical connections	Check the operation.
Temperature sensor	Check electrical connections	Check the operation
Air supply and extract system	Check the connections	Clean.
Air duct system	Check the tightness	Clean.
Dampers, diffusers, grid	Check the tightness of connections	Clean.
Switching unit (contactor)		Every 3 to 4 months, visually assess the functioning of the switching unit (contactor), i.e. make sure that its casing has no signs of melting or is not thermally damaged and does not produce any unusual sounds. All the contactors in the product or in its accessories must be checked.
Condensate discharge assembly	Check the condensate discharge assembly and make sure that water runs from the drip tray properly.	Clean.

6.3. COVER OPENING



It's necessary to stop the unit before opening it's doors. Disconnect the main switch and open doors after fans stop completely (approximately 2 min.). It is necessary to assure, that the main switch cannot be turned on by the third parties.

Three opening/removal methods are possible:

1. The ordinary opening of doors using hinges;
2. The removal of doors using a rails system;
3. The removal of the doors of the floor-mounted version.

To unscrew the covers, you can use the key attached as an accessory.



AmberAir Compact 1 CX P has only two covers, while Compact 2-4 CX P has three.

The opening of the doors of the ceiling-mounted version using hinges

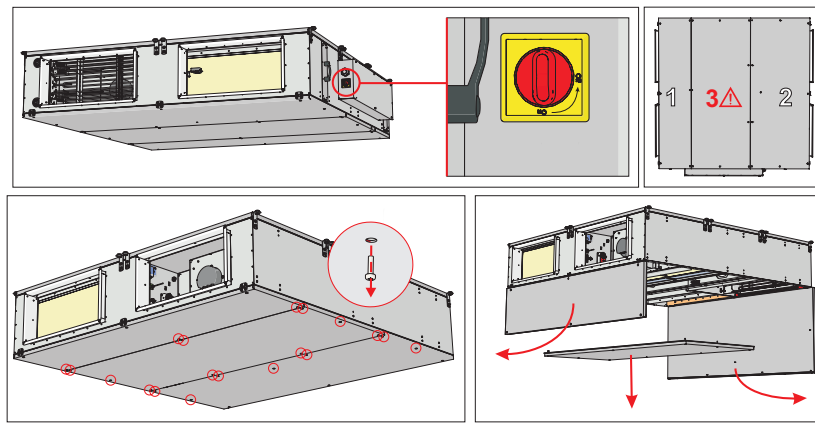

The removal of covers using rails

Unscrewing the covers

- First unscrew the screws holding the covers at the side of the holders. Thus gradually turn all the screws up to the other side of the cover.
- One edge of the cover should be placed on a holder. Screw all the covers in the same manner. The cover with the condensate bath may only be removed after disconnecting it from the drainage pipe.

The preparation of the cover for use

- After all the screws are unscrewed, the cover is free. It is moved aside and back and is so removed from the holder and placed onto the rails.

Method of use

- The covers can be directly removed from the rails themselves or pushed to the other side of the product.

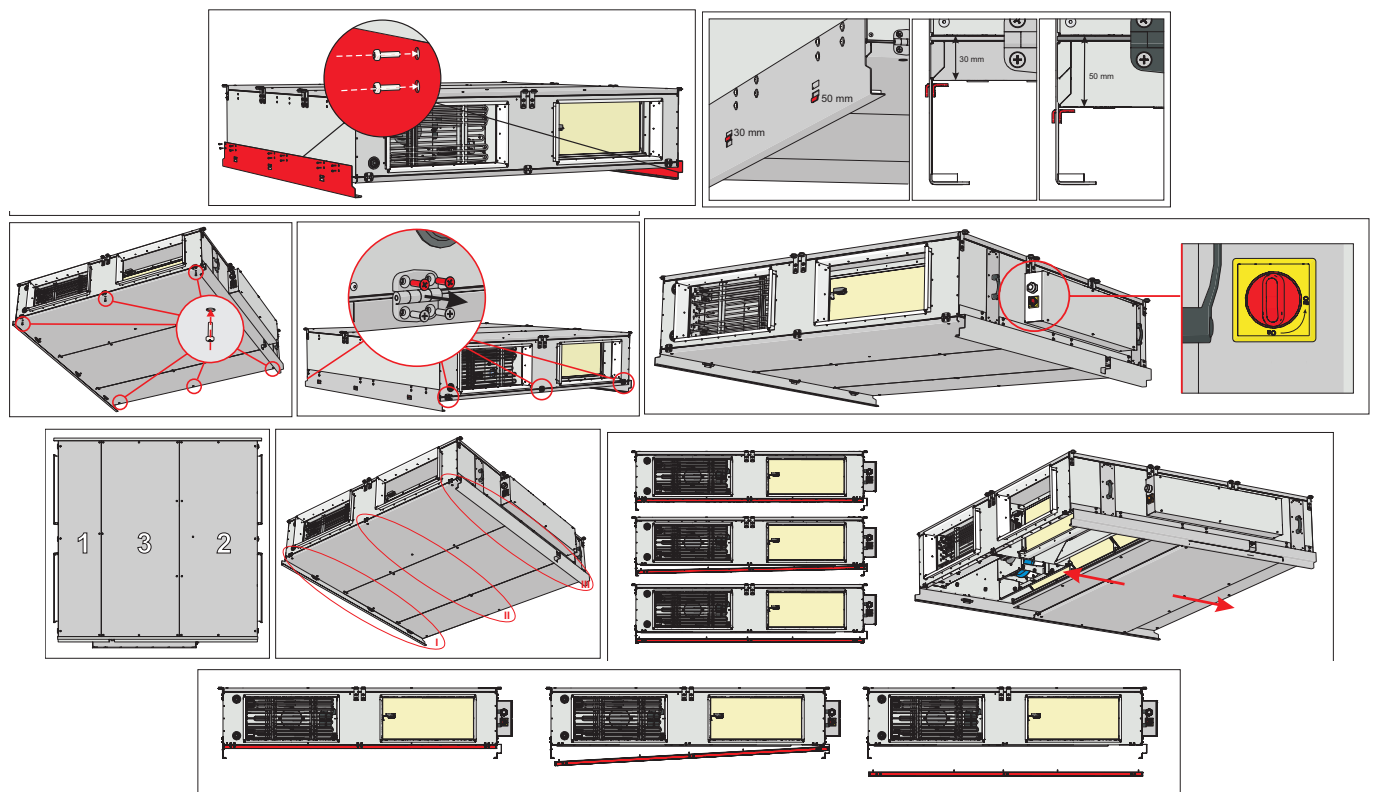

The removal of the cover of the floor-mounted version

- When using supporting bases, the ground-mounted product is maintained from above. Open the covers by unscrewing the screws using a hexagonal key.
- Unscrew the screws 1 and 2 of the side covers of AmberAir Compact 2-3 CXP. Carefully open the covers. Unscrew and carefully remove the middle cover No 3.



The door must be screwed on after maintenance. Recommended tightening is 2,7 N-m.

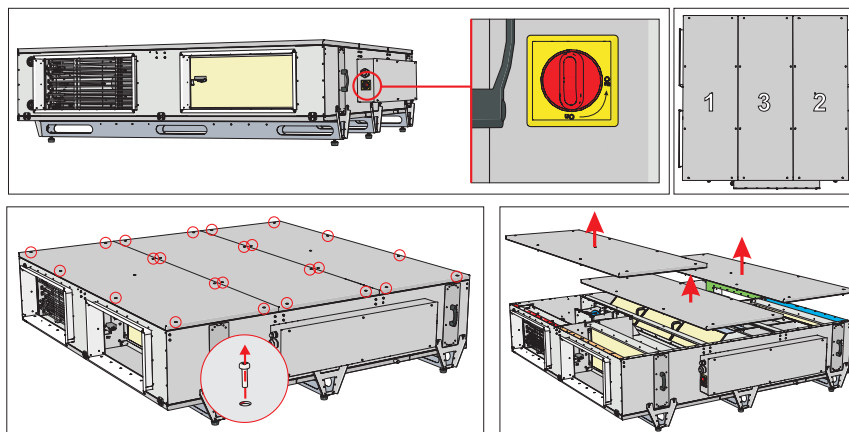

6.4. FILTERS MAINTENANCE

- The filters can be replaced by opening the side caps or covers.
- When replacing the filters from the side, fold out the filter cap holders one by one and remove the cap and the filter.
- If the space is not sufficient to remove the filters from the side, they may be replaced from the top by opening the doors.
- The opening of the doors described in the section **"COVER OPENING"**.
- After opening the doors, unscrew out the filter holder screws from one and the other side.
- Fold out the released holder aside, thus removing the filter.
- When inserting a filter, make sure that the arrow on the filter coincides with the flow direction.

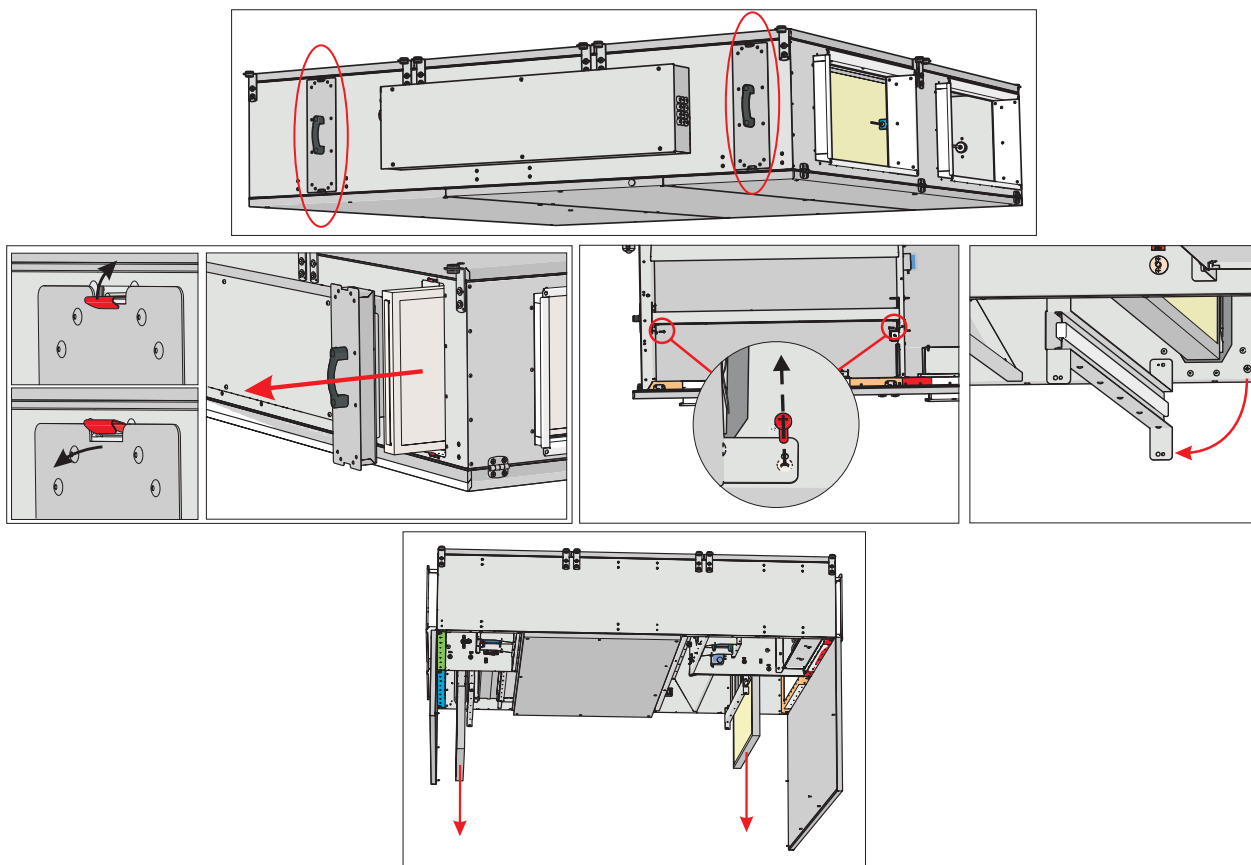

After changing the filters, please reload filter timer in the remote controller. It is strictly prohibited to operate the unit without filters!



It is recommended to change the filters every 3-4 months, or according to filter timer indication in remote control panel or BMS.

6.5. FANS MAINTENANCE



Before starting any maintenance or repair works, make sure that the unit is disconnected from the electrical network and/or that the main circuit breaker is turned off.

- Fan maintenance should be performed by experienced and trained staff only.
- The fan should be inspected and cleaned at least once per year.

- Prior to commencing any maintenance or repair works, make sure the unit is disconnected from the power source.
- Proceed to maintenance and repair after any fan rotation is stopped.
- Observe staff safety regulations during the maintenance and repair works.
- The fans features a heavy-duty ball bearing design. The motor is completely sealed and free of maintenance.
- Detach the fan from the unit.
- Disconnect fan air pressure hose.
- The impeller should be particularly checked for built-up material or debris that may cause an imbalance. An excessive imbalance may lead to accelerated wear on the motor bearings and cause vibration.
- Clean the impeller and inside the housing with a mild detergent and a damp soft cloth.
- Clean impeller and inside housing with soft, non-soluble and non-corrosive detergent and water, with ph (6-8).
- Do not use high-pressure cleaners, abrasive materials and sharp tools or caustic solvents that may scratch or damage the housing and impeller.
- Do not plunge the motor in any fluid while cleaning the impeller. Make sure the impeller's balance weights are in place.
- Make sure the impeller is free of any obstacles.
- Install the fan back into the unit. Connect fan power and control signals. Connect air pressure hose.
- In case the fan does not automatically start up or stop after maintenance, contact the manufacturer. The malfunction of the fan can be identified by the pressure in the system (when pressure switches are connected). In case of any fault in the fan motor, a notice will appear on the control panel.



After unpacking AmberAir Compact 4 CX P, open the side covers and unscrew the supporting legs, which are used for transportation, from the fans.

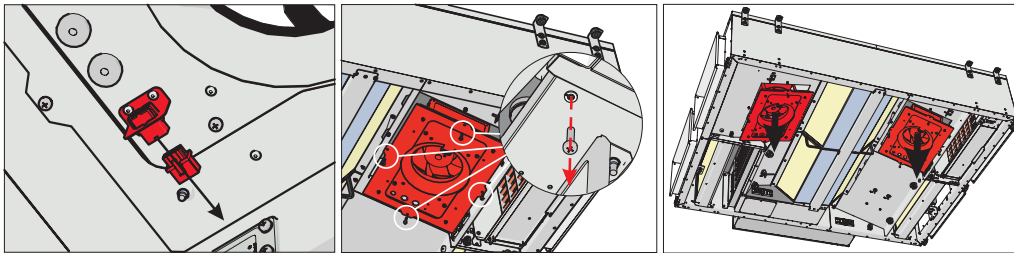

Figure 6.5.1. AmberAir Compact 1 CX P ceiling-mounted version

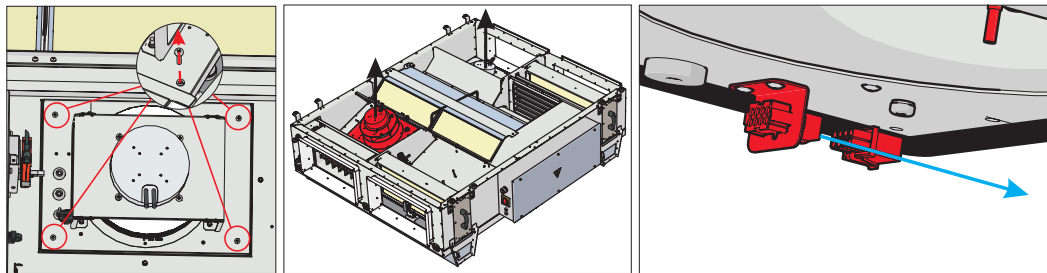

Figure 6.5.2. AmberAir Compact 1 CX P floor-mounted version

The fans of both the floor-mounted and ceiling-mounted versions are maintained in the same manner.

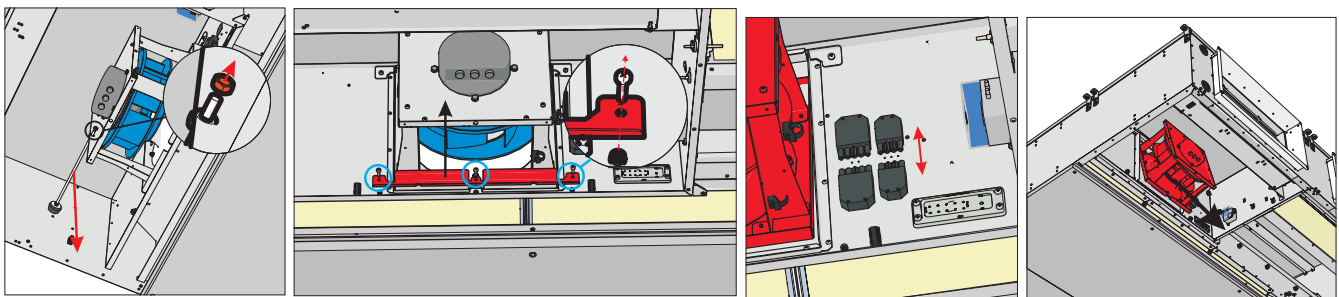

Figure 6.5.3. AmberAir Compact 2-4 CX P

6.6. HEAT EXCHANGER MAINTENANCE

- Be sure to disconnect the unit from power source before performing any maintenance or repair.
- Proceed to maintenance and repair after any rotation in the fan stopped.
- Clean the heat exchanger once a year.
- Carefully remove the heat exchanger cartridge and immerse it in a container with soapy water (do not use soda).
- Then wash the cartridge with a weak hot water flow (excessively strong water flow may bend its plates).
- The heat exchanger may be installed into the unit only when it is completely dry.
- The heat exchangers are removed either from the top or from the bottom.

From the top (the ceiling-mounted version):

- Unscrew the 4 screws of the longitudinal bracket.
- Remove the bracket.
- Unscrew the holder of the heat exchanger, 3 screws.
- The heat exchanger is held by the second holder at the other end of the heat exchanger.



After the holder is unscrewed, the heat exchanger becomes loose. If it is hanged, it will drop.

- Remove the spacers of the heat exchangers.

From the bottom (the floor-mounted version):

- Unscrew the 4 screws and remove the longitudinal bracket.
- Unscrew the 2 holders of the heat exchanger.
- Remove the spacers and the heat exchanger.

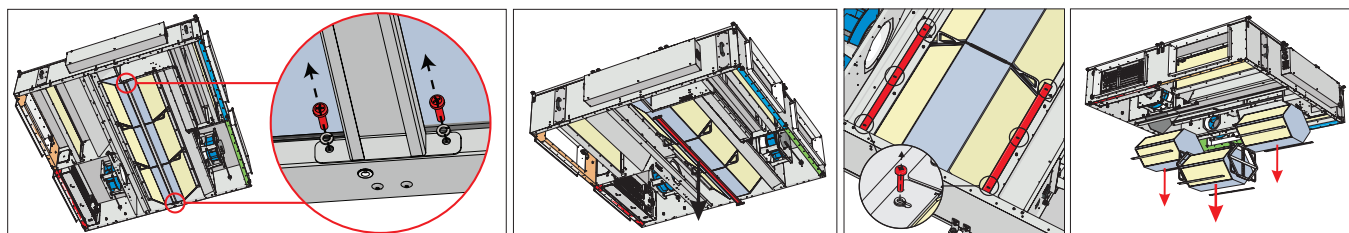

Figure 6.6.1. AmberAir Compact ceiling-mounted version

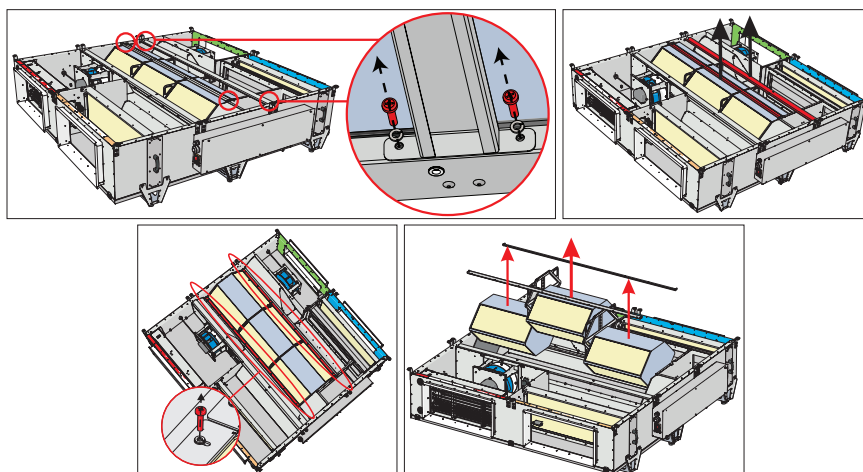

Figure 6.6.2. AmberAir Compact 1-2 CX P, 4 CX P floor-mounted version

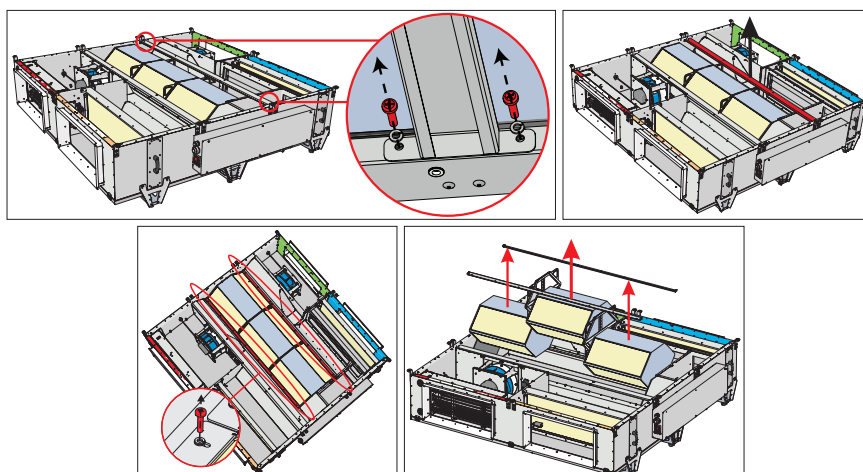

Figure 6.6.3. AmberAir Compact 3 CX P floor-mounted version

6.7. ELECTRIC, WATER HEATER MAINTENANCE

- In case manual protection is activated, check for a fault before pressing the RESET button. If the fault is identified after it has been rectified, press the RESET button using a screwdriver or a similar object.
- Heaters are equipped with 2 thermal protection devices: an automatic self-resetting protection device that is activated at +50 °C, and a manually restored protection device that is activated at +100 °C.

- After activation of the manually restored protection device, make sure that the unit is disconnected from the power supply. Wait until all heating elements cool down and the fans stop completely. After the failure is detected and rectified, press the RESET button before starting the unit. The failure can be identified by a qualified technician only.
- Electrical heater does not require additional servicing. If necessary, electric heater can be removed.
- Disconnect product unit from electric power source
- Open the doors of the product.
- Disconnect the electrical heater from the harness.
- Unscrew 4 screws and remove the heater. Do not take heater at the heating element, but hold it at casing.
- Before installing heater back, please pay attention at the airflow direction markings.

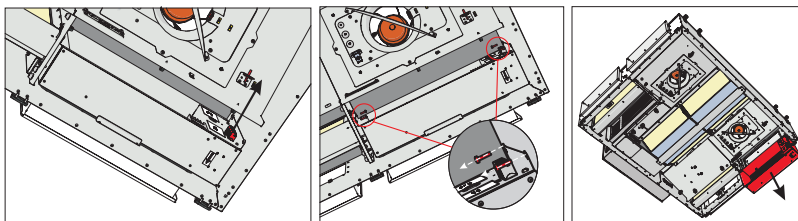

Figure 6.7.1. Electric heater maintenance

- Disconnect product unit from electric power source.
- Open the doors of the product.
- Drain the heating liquid from the system.
- Disconnect the heater from the system.
- Unscrew 4 screws and remove the cap.
- Remove the thermostat sensor from inside.
- Remove the side seals from the heater pipes.
- Unscrew 4 screws and remove the heater.

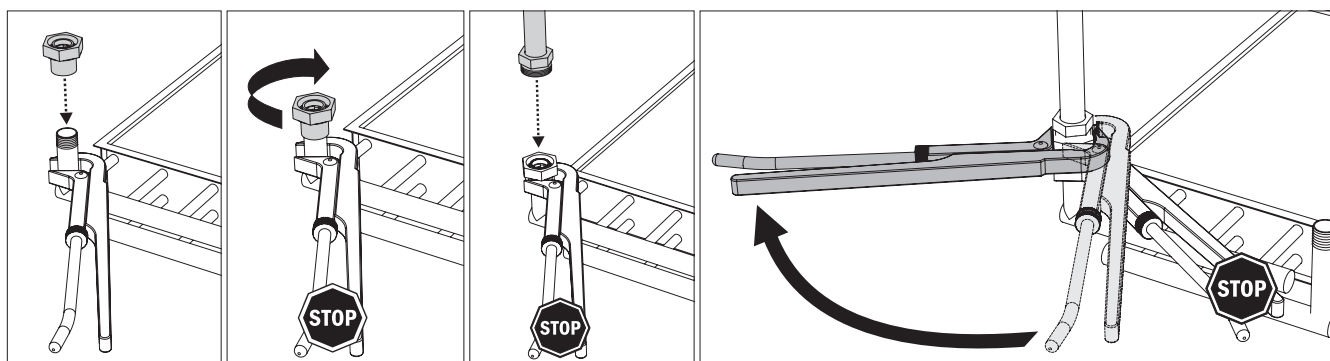
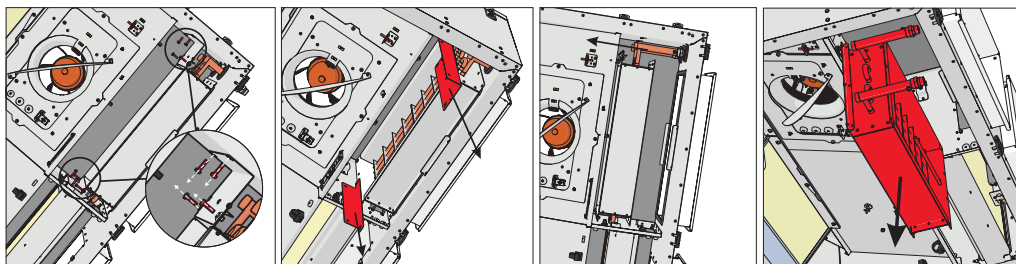
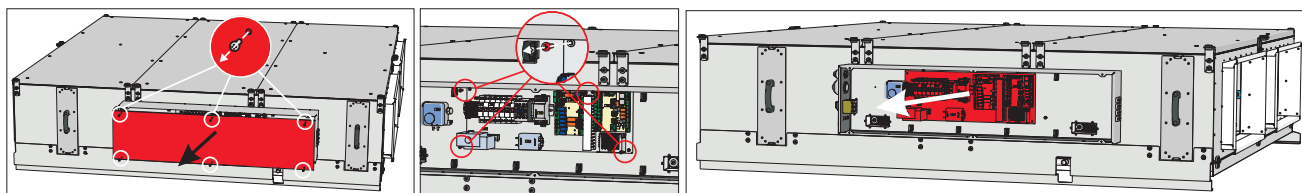

Figure 6.7.2. Water heater maintenance

6.8. CONTROL BOARD MAINTENANCE

- Disconnect product unit from electric power source.
- Unscrew and remove the control box cover.
- Disconnect all necessary cables, wires, hoses and connectors in order to remove the control board and unscrew the control board mounting bolts.
- Remove the control board.
- To reassemble, follow all maintenance steps in reverse order. When re-connecting cables, wires, hoses and connectors, make sure to match each wire, hose and connector to the corresponding connection terminal and connector.



7. CONTROL

7.1. DEVICE CONTROL

Ventilation unit equipped with MCB control board can be controlled with remote controller, WEB interface or mobile app via MB-GATEWAY and BMS (building management system). More information provided in the table below.

With MB-GATEWAY	Remote control panels	BMS direct connection	Wireless communication
Web interface SALDA AIR mobile application BMS over Modbus TCP/IP BMS over BACnet IP	Stouch ST-SA-Control	Modbus RTU (RS485)	MB-GATEWAY + WIFI router

7.2. DEVICE FUNCTIONS

All MCB control boards has the same software with all functions included. Full function list and description you can find on the MCB control board manual. However, operation and control of the device depends on the following factors:

1. Selected control interface (remote control panel, MB-GATEWAY, etc.). The selected interface affects access to the information and settings, however, it does not affect the logic of control. Full access to the information and settings is available on ST-SA-Control, MB-GATEWAY WEB application and SALDA AIR mobile application.
2. Unit configuration (internal/external components, sensors and control board settings)



For unit control instructions, refer to the operation manual of the existing control device.

8. CONNECTION OF ACCESSORIES

8.1. FIRE AND FIREPLACE PROTECTION

Fire and Fireplace protection signal inputs must be normally closed, until the fire and fireplace protection systems are not connected jumpers are installed in the factory.

Product AmberAir Compact CXP can be equipped with fire dampers for extract and supply air. Dampers are controlled by Spring-return actuators (A1/A2). Upon activation of DO1 and DO2 signals the dampers shall open. When DO1/DO2 is deactivated, the dampers shall close. Dampers can also be equipped with damper position switches. K5/K7 switches for opened damper signal. K6/K8 switches for closed damper signal. Fire and Fireplace protection systems wiring diagrams can be found on section 8.9.



More information can be found in the MCB Technical Manual.

8.2. EXTERNAL CO₂/RH SENSORS

AmberAir Compact CXP units have one connection for external CO₂/RH (input 0-10 VDC) sensor. Sensor wiring diagram can be found on section 8.9.

These sensors are intended for the following 2 functions: supply air RH and extract CO₂ detection. Supply air RH is measured inside the supply air duct. The CO₂ transmitter is installed in the extract air duct or room.

8.3. ROOM CO₂ TRANSMITTER INSTALLATION RECOMMENDATION

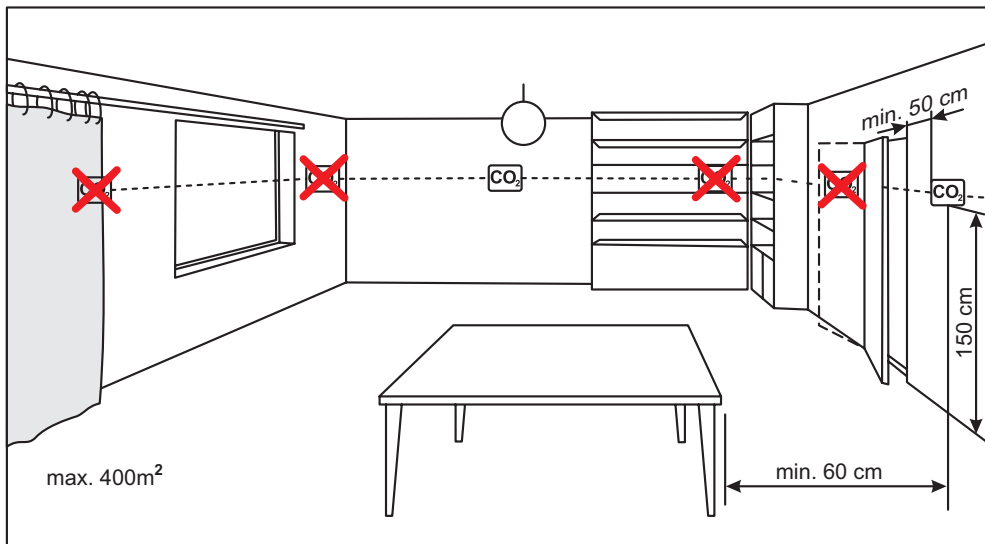

If the duct CO₂ transmitter is used, it must be installed in the extract air duct. To install duct transmitters, hole drilling tools are required.

8.4. CO₂ CONCENTRATION ACCORDING TO PETTENKOFER LIMIT

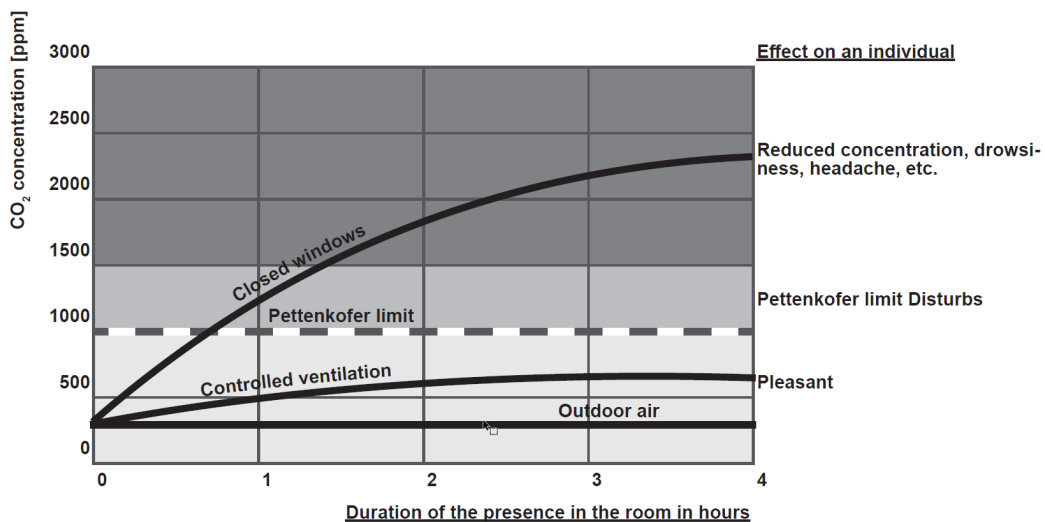

8.5. CONNECTION OF SUPPLY AND EXHAUST AIR DAMPERS

AmberAir Compact CXP units can be equipped with supply air and exhaust air dampers. Dampers are controlled by Open/Close or Spring-return actuators.

M2, M3 - Open/Close or Spring-return damper actuators. Upon activation of DO5 the dampers shall open. Upon activation of DO6 the dampers with Open/Close actuators shall close. Dampers with Spring-return actuators close when DO5 is deactivated.

Damper wiring diagrams can be found on section 8.9.

8.6. CONNECTION OF REMOTE CONTROL PANEL OR MODBUS

X18 connector is for Remote controller.

X19 connector is for BMS.

S1 DIP switch is for X19.

Switch	Position	Purpose
S1	1	120 Ohm termination load (On/Off)
	2	1 kOhm RS line pull-up (On/Off)
	3	1 kOhm RS line pull down (On/Off)

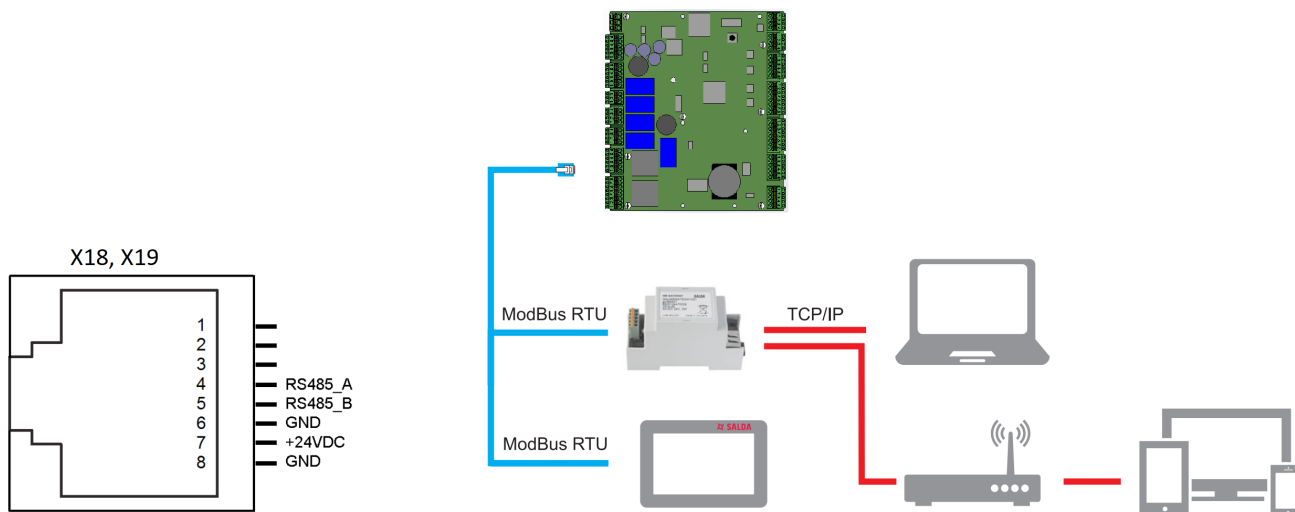

8.7. WATER HEATER CIRCULATION PUMP AND VALVE ACTUATOR

Water heater circulation pump and valve actuator can only be connected to the units that are designed to operate with water heater.

Wiring diagram

Valve actuator is controlled by 0-10 VDC signal. Circulation pump is controlled by On/Off signal.

Control board MCB controller X12: 2;3; X14: 6; and MCB EX2 controller X39: 1;2;3;

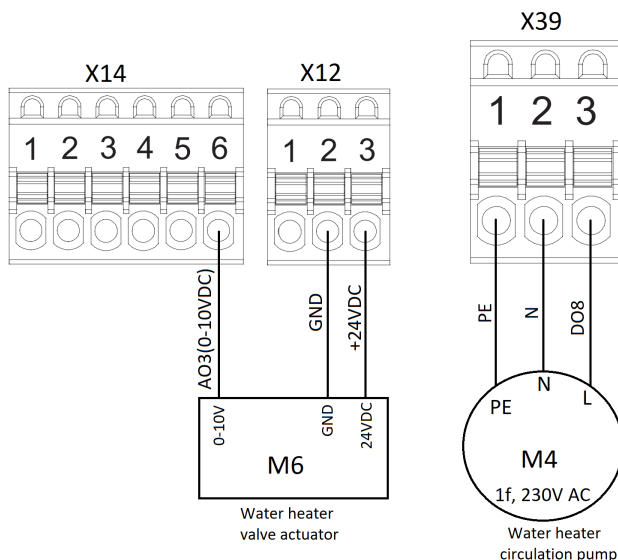

8.8. PREHEATER AND COOLER

AmberAir Compact CXP units can be equipped with external electrical or water preheater. Automatic and manual protection devices must be connected to MCB EX1 controller's X21 connector when electric preheater is equipped with these connection terminals. Otherwise, jumpers are installed in the X21 connector protection inputs. Water preheater consists of circulation pump, valve actuator and temperature sensor. Only one preheater can be connected at the time.

CXP units can also be equipped with external water cooler or DX cooler. Water coolers consists of circulation pump, valve actuator and temperature sensor. Control board has DX cooler inputs/outputs: valve actuator control, failure input, reverse output and power line. Only one cooler can be connected at the time.

Preheater and cooler wiring diagrams can be found on section 8.9.

8.9. ELECTRICAL DIAGRAMS AND ABBREVIATION IN ELECTRICAL CIRCUIT DIAGRAMS

ABBREVIATION	EXPLANATION	ABBREVIATION	EXPLANATION
CB	Control board	System mode switch	System mode switch (START/STOP)
UC	Components to be connected by the user	Fan speed switch	Fan speed switch (BOOST)
N1	MCB control board	M4	Water heater circulation pump
N2	EX1 control board	M6	Water heating indicator output 0-10VDC
N3	EX2 control board	T1	Water heater protection thermostat
Q5	Electrical pre-heater power supply circuit breaker	T2	Cooling switching thermostat
K3	Electrical pre-heater contact	TV	Water heater temperature sensor
PE1	Electric pre-heater	M12	Water heater control output 0-10VDC
A1	Fire alarm damper actuator I (supply air)	TV2	Water heater temperature sensor
A2	Fire alarm damper actuator I (exhaust air)	M16	Water heater circulation pump
K5	Fire alarm damper I open	TV3	Water cooler temperature sensor
K6	Fire alarm damper I closed	M13	Water cooler control output 0-10VDC
K7	Fire alarm damper II open	M14	Water cooler circulation pump
K8	Fire alarm damper II closed	M15	DX cooler control output 0-10VDC
M2	Supply air damper	K4	DX cooler error
M3	Exhaust air damper	X40 [1:2]	DX cooler reserve mode (NO – cooling / NC – heating)
FA	Fire alarm	X41 [1:2]	DX cooler power supply
FPP	Fireplace protection	Transmitter2	Exhaust air CO ₂ sensor
START	Operation indicator		
START	Warning indicator		

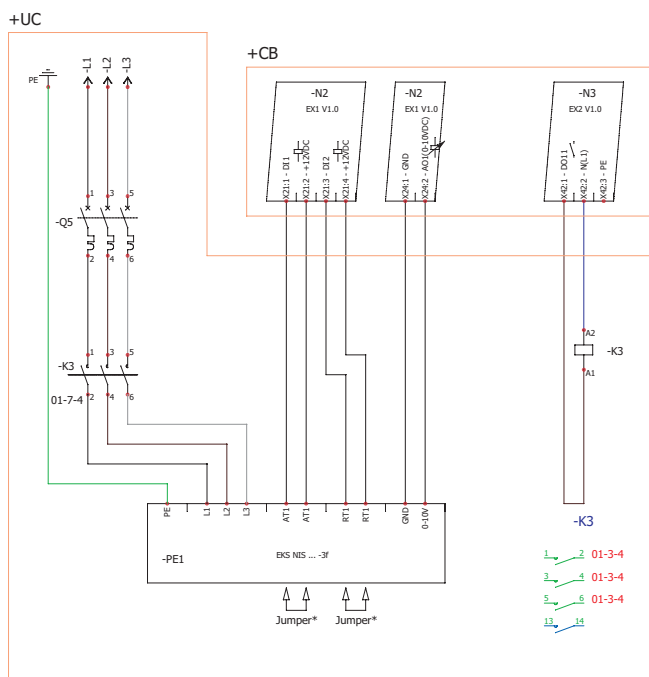

Figure 8.9.1. Electrical external pre-heater

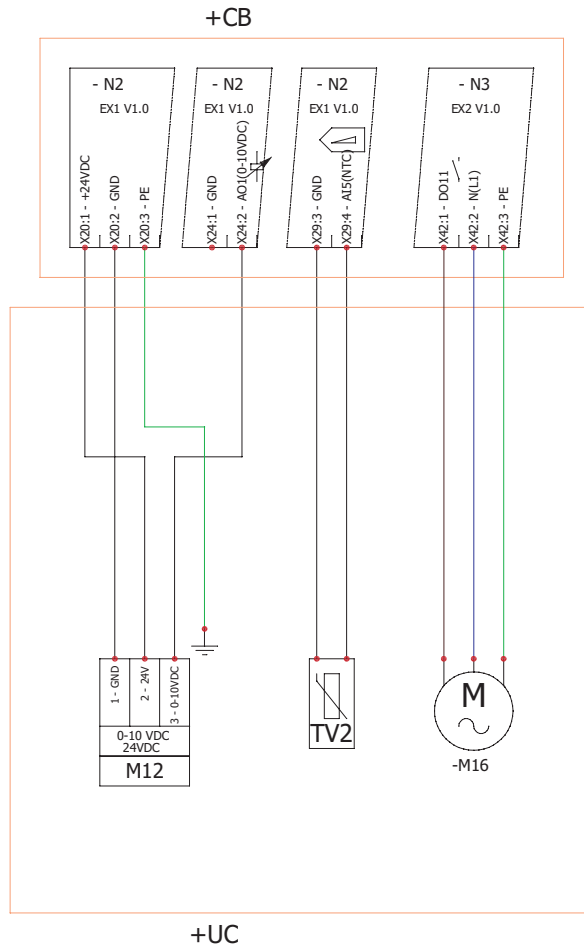

Figure 8.9.2. External water pre-heater

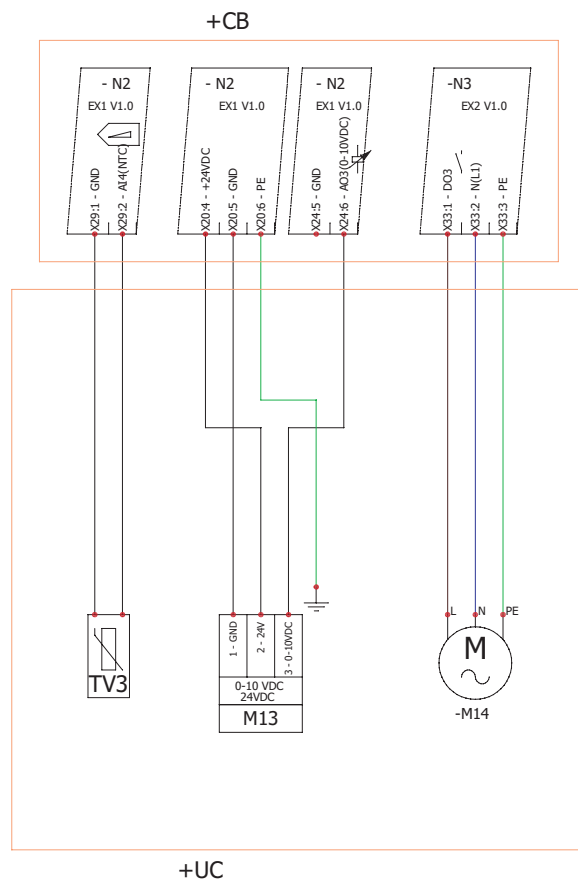

Figure 8.9.3. External water cooler

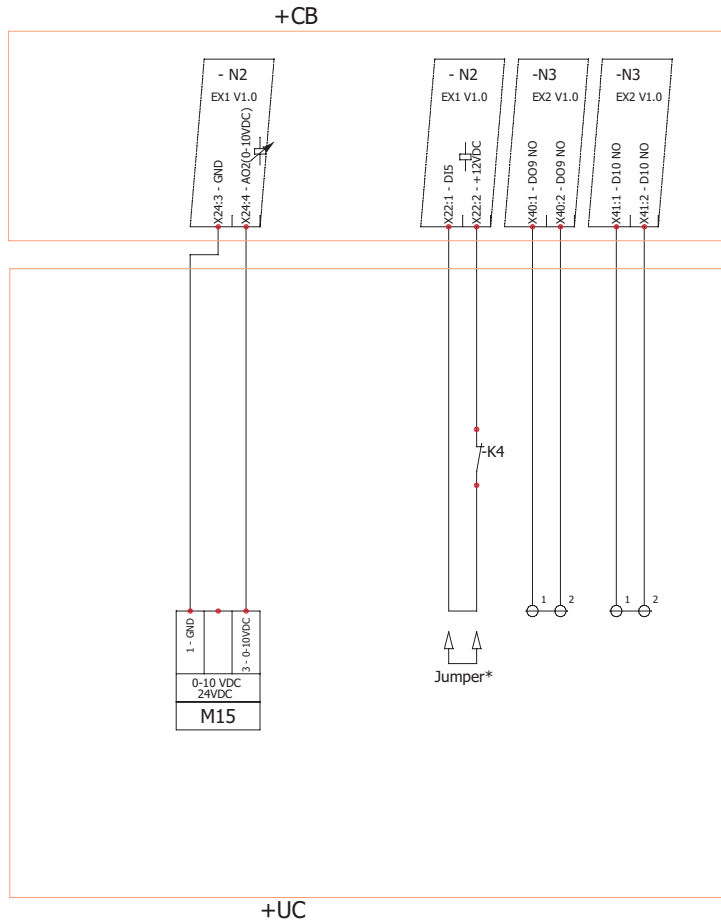

Figure 8.9.4. External DX cooler

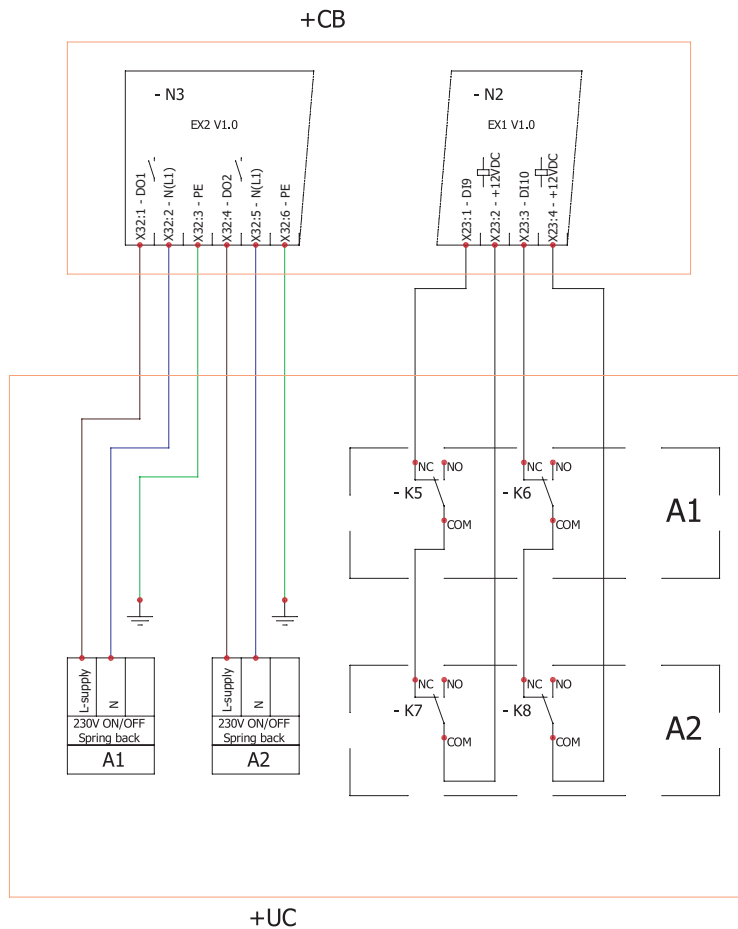

Figure 8.9.5. Fire protection connection

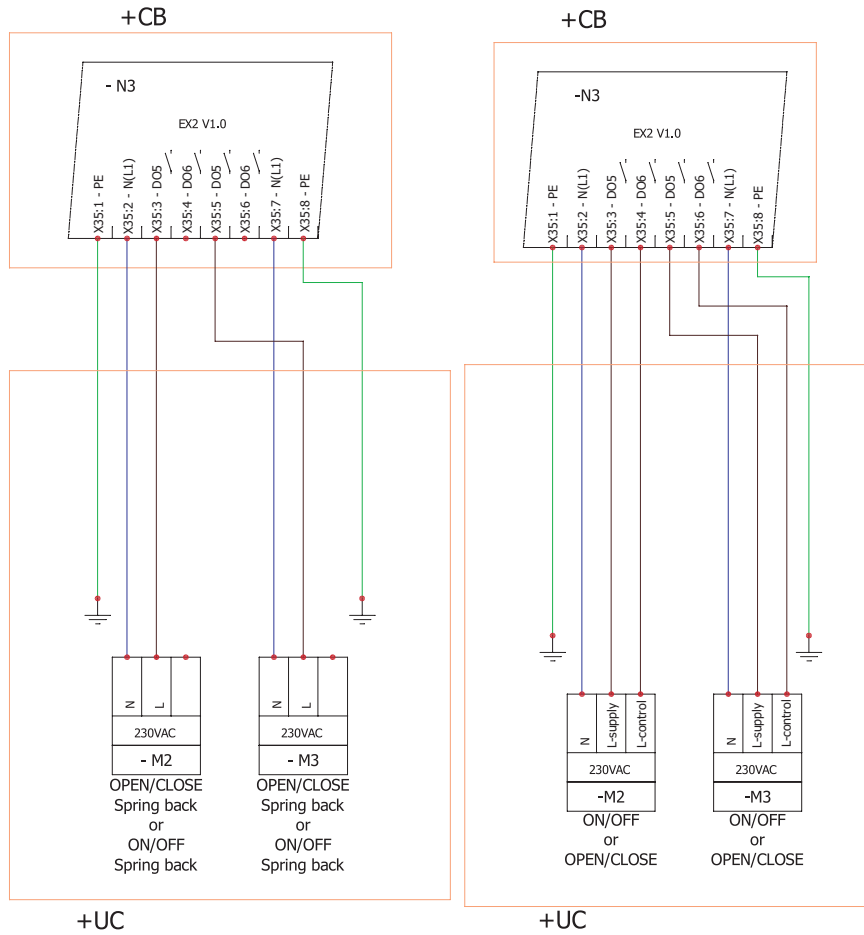

Figure 8.9.6. Motorised air dampers

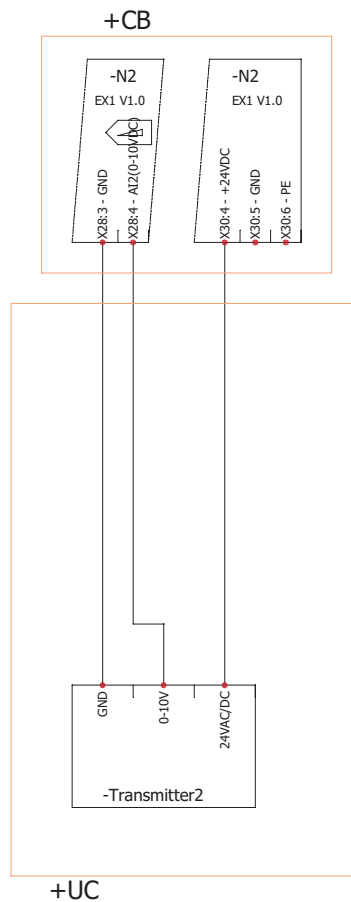

Figure 8.9.7. CO₂ or RH sensors

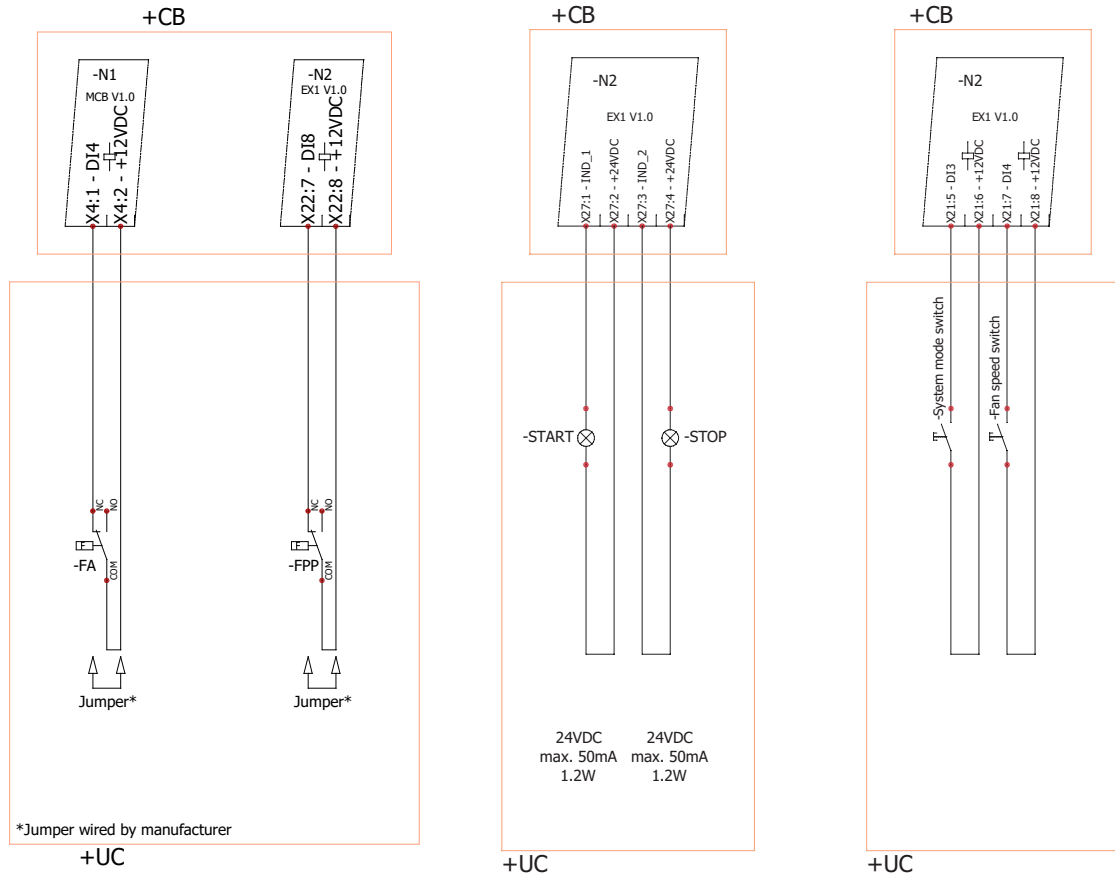

Figure 8.9.8. Unit status indication / mode change / fire alarm inlet / fireplace function input

All the external electrical connections must be implemented in accordance with effective legal acts and safety requirements.

9. POSSIBLE FAULTS AND TROUBLESHOOTING

FAILURE	CAUSE	EXPLANATION / CORRECTIVE ACTIONS
The unit is not operating	No supply voltage	Check whether the device is connected to the power network.
	The protection device is off or a current leakage relay is active (if installed by the installer)	Switch on only if the unit condition has been evaluated by a qualified electrician. If the system failed, the failure MUST BE rectified prior to switching the system on.
The air supply heater or pre-heater is not operating or malfunctioning (if installed)	Too low airflow in air ducts activates automatic protection	Check if the air filters are not clogged. Check if the fans are rotating.
	Manual safety device is activated	Possible heater or unit failure. MUST contact the servicing staff for failure detection and its elimination.
Too low airflow at rated fan speed	Clogged supply and/or extract air filter(s)	Filter replacement needed.
The filters are clogged and no message is shown on the remote control	Wrong time on filter timers or their switch is broken, or its pressure is set improperly	Shorten filter timer time till the message of clogged filters appears or replace the pressure switch of the filters, or set their proper pressure.

10. ECODESIGN DATA TABLE



More details of the unit and each unit's component can be found on the "VentMaster" selection app.

11. DECLARATION OF CONFORMITY

Manufacturer

SALDA, UAB
Ragainės g. 100
LT-78109 Šiauliai, Lithuania
Tel.: +370 41 540415
www.salda.lt

Hereby confirms that the following products - Air Handling units:

AmberAir Compact*

(where by „**“ indicates possible unit installation type and modification)

provided it was delivered and installed in the facility in accordance with the included installation instructions, comply with all applicable requirements in the following directives:

Machinery Directive 2006/42/EC
EMC Directive 2014/30/EU
Low Voltage Directive 2014/35/EU
Ecodesign Directive 2009/125/EC
RoHS 2 Directive 2011/65/EU
Pressure Equipment Directive 2014/68/EU

The following regulations are applied in applicable parts:

Ecodesign requirements for ventilation units Nr. 1253/2014

The following harmonized standards are applied in applicable parts:

EN 1886:2009 - Ventilation for buildings - Air handling units - Mechanical performance.
EN 13053:2019 - Ventilation for buildings. Air handling units. Rating and performance for units, components and sections.
EN ISO 12100:2012 - Safety of machinery - General principles for design - Risk assessment and risk reduction.
EN 60204-1:2018 - Safety of machinery - Electrical equipment of machines - Part 1: General requirements.
EN 60335-1:2020 - Household and similar electrical appliances. Safety. Part 1: General requirements.
EN 60529:1999/A2:2014/AC:2019 - Degrees of protection provided by enclosures (IP code).
EN 61000-6-2:2019 - Electromagnetic compatibility (EMC) -- Part 6-2: Generic standards - Immunity for industrial environments.
EN 61000-6-3:2021 - Electromagnetic compatibility (EMC) -- Part 6-3: Generic standards - Emission standard for residential, commercial and light-industrial environments.

Should any alterations be made in the products, this declaration will no longer apply.

Notified body: VšĮ Technikos priežiūros tarnyba, Naugarduko g. 41, LT – 03227 Vilnius, Lithuania, identification number 1399.

Quality: SALDA UAB activities are in line with the international quality management system standard **ISO 9001:2015**.

Date 2022-01-03



Giedrius Taujenis
Product manager

12. WARRANTY

1. All equipment manufactured in our factory is checked in operating conditions and tested before delivery. The test protocol is supplied together with the unit. The equipment is shipped in good working condition to the end client. The unit is warranted for the period of two years from the date of the invoice.
2. If equipment is found to have been damaged during transportation, a claim should be made against the carrier, as we assume no responsibility for such damage.
3. This warranty does not apply:
 - 3.1. when transportation, storage, installation and maintenance instructions of the unit are violated;
 - 3.2. when the equipment is improperly maintained, mounted - inadequate maintenance;
 - 3.3. when the equipment without our knowledge and permission has been upgraded or unskilled repairs were made;
 - 3.4. when the unit was used not for its original purpose.
 - 3.5. Company SALDA UAB is not responsible for potential loss of property or personal injury in cases where the Air Handling unit is manufactured without the control system and the control system is installed by the client or the third parties. The manufacturer's warranty does not cover devices that will be damaged by installing the control system.
4. This warranty does not apply to these malfunction cases:
 - 4.1. mechanical damage;
 - 4.2. damage caused by entering outside objects, materials and liquids;
 - 4.3. damage caused by natural disasters, accidents (voltage change in the electricity network, lightning, etc.).
5. The company assumes no liability for the damage to its products neither directly nor indirectly, if the damage is caused by failure to comply with the installation and mounting regulations, deliberate or careless users or third-party behaviour.

These conditions are readily discernible when the equipment is returned to our factory for inspection. If the direct client determines that equipment is found to be faulty, or a breakdown occurred, he should inform the manufacturer within five working days and deliver the equipment to the manufacturer. Delivery costs should be covered by the customer.



The manufacturer reserves the right to change this technical passport at any time without prior notice if some typographic errors or inaccurate information is found, as well as after improving the apps and/or the devices. Such changes will be included in the new issues of the technical passport. All illustrations are just for information and thus may differ from the original device. The newest manual version is available at <https://select.salda.lt>

12.1. LIMITED WARRANTY COUPON

Warranty term
24 months*

I received the complete package and technical manual of the product ready for usage. I have read the warranty terms and conditions and agree with them:

.....
 Customer's signature

*Refer to WARRANTY CONDITIONS

Dear User, we appreciate your choice and do hereby guarantee that all ventilation equipment manufactured by our Company is inspected and thoroughly tested. An operational and high-quality product is sold to the direct buyer and shipped from the territory of the factory. It is provided with a 24-month warranty from the issue date of the invoice. Your opinion is important to us, thus we always look forward to hearing your comments, feedback, or suggestions regarding technical and operational characteristics of the Products. In order to avoid any misunderstandings, please read the instructions for installation and operation of the product as well as other technical documents of the product carefully. The number of the Limited Warranty Coupon and the serial number of the product specified on the silver identification sticker attached to the housing must match. The Limited Warranty Coupon shall be valid provided that the seller's stamps and records are clear. It is not allowed to change, delete, or rewrite the data specified on it in any manner – such a coupon shall be invalid. With this Limited Warranty Coupon the manufacturer confirms his obligations to implement the imperative requirements established by effective laws on protection of consumer rights in the event of identification of any defects of the products. The manufacturer reserves the right to refuse provision of free warranty servicing in cases when the warranty conditions listed below are disregarded.

PRODUCT MAINTENANCE TABLE

Product name*

SERIAL number*

Installation	Interval	Date
Fan cleaning	Once per year**	
Heat-exchanger cleaning	Once per year**	
Filter replacement	Every 3-4 months**	

* - Look at the product label.

** - At least.



NOTE. The customer shall be required to complete the Product Maintenance Table.

MANUALS IN OTHER LANGUAGES

DE



<https://select.salda.lt/file/aacompactcxpde>

LT



<https://select.salda.lt/file/aacompactcxplt>



MAN000348



Ragainės g. 100
Šiauliai LT-78109, LITHUANIA

+370 41 540 415
office@salda.lt