

Modification	Date	Name	Date	Ed.	Original	Replacement of	Replaced by
	2023-11-21		2023-11-21	justasabys		Control board for AHU	
<b>SALDA</b>							
Power supply							
Project Nr.	= 23101914			Offer nr.			
Page	1			Page	1 / 12		

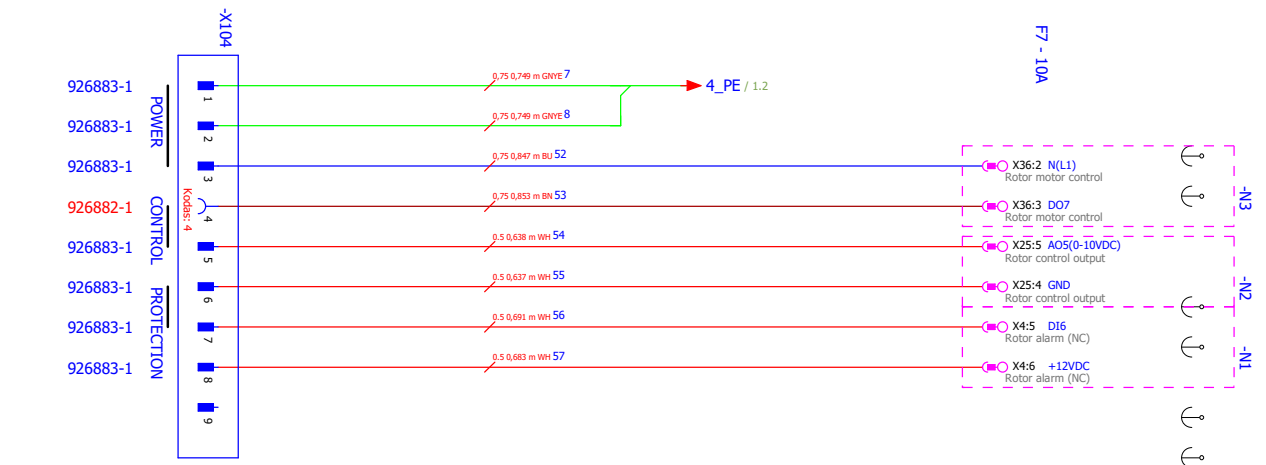
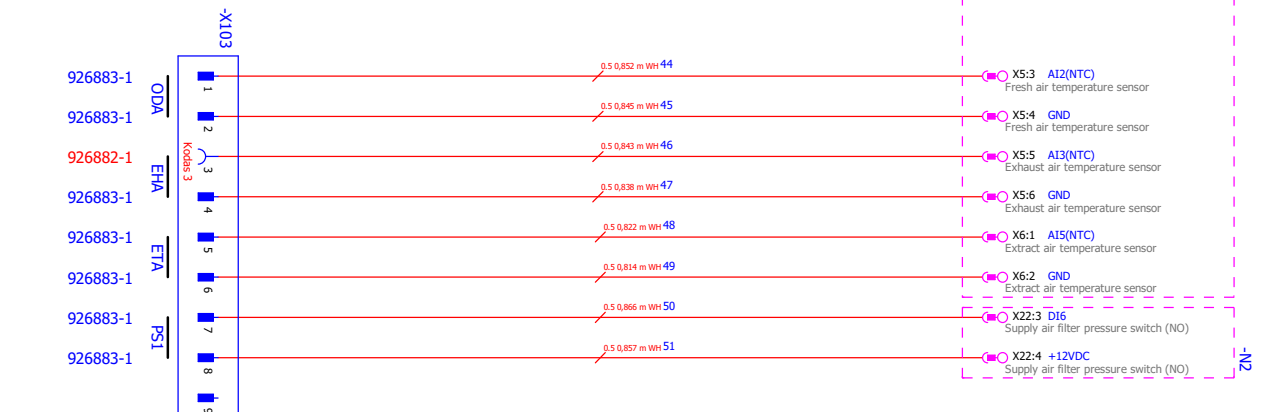
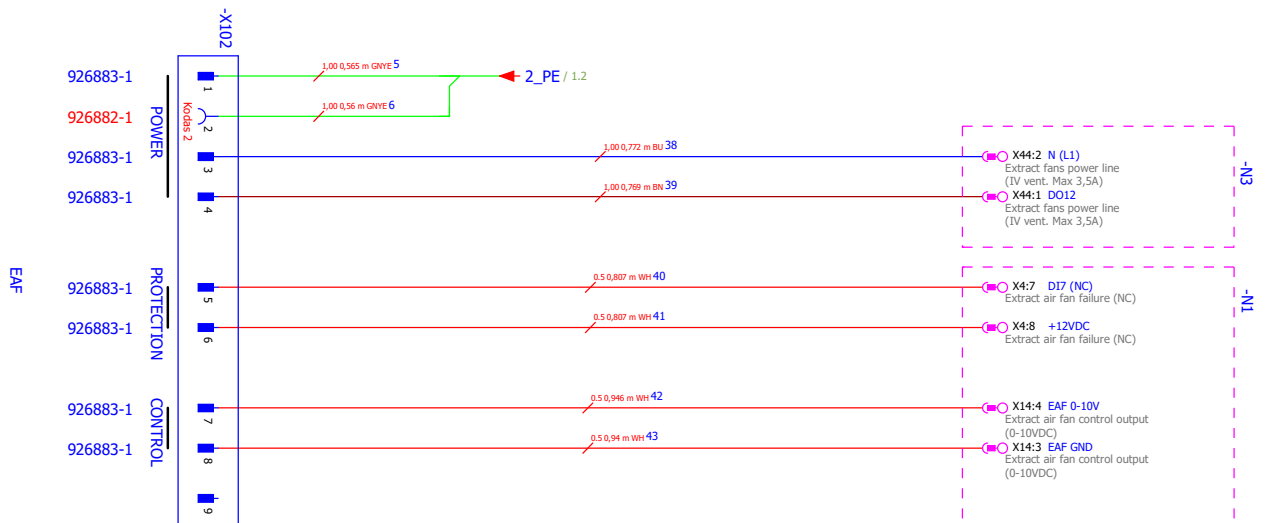
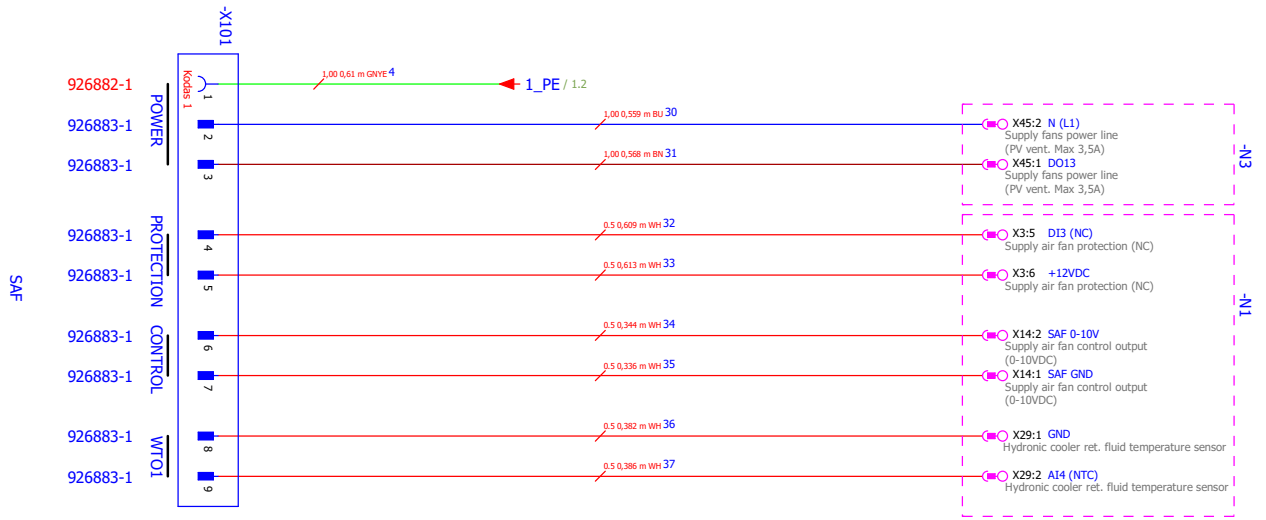

Modification	Date	Name	Date	Ed.	Apr.	justasabys	2023-11-21	Control board for AHU	Replacement of	Replaced by
<b>SALDA</b>										
								Fans, Sensors, PS		
Project Nr.								Offer nr.	= 210.1914	
Page								Page	2	
Page								Page	2 / 12	

Modification	Date	Name	Date
--------------	------	------	------

			2023-12-07
		Ed:	Vidas Petruis
		Appr:	
		Original	

Control board for AHU

PSZ wires, Thermostat, Communication

Project Nr.	+ 2101314
Offer nr.	

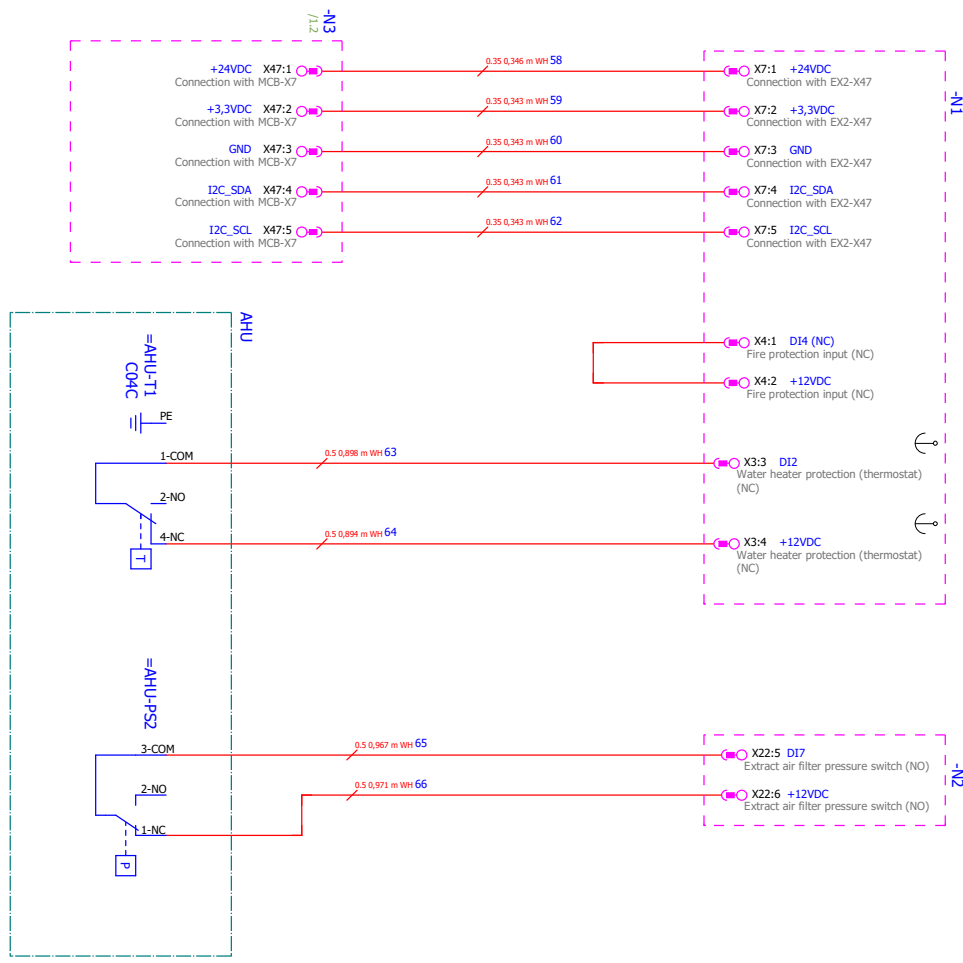

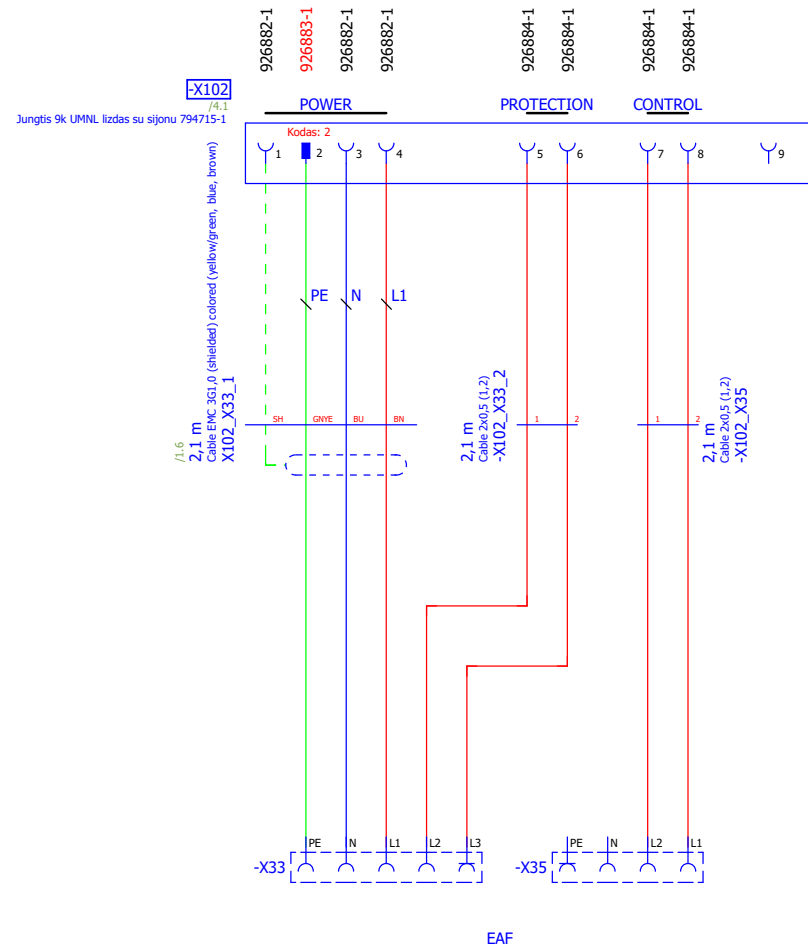
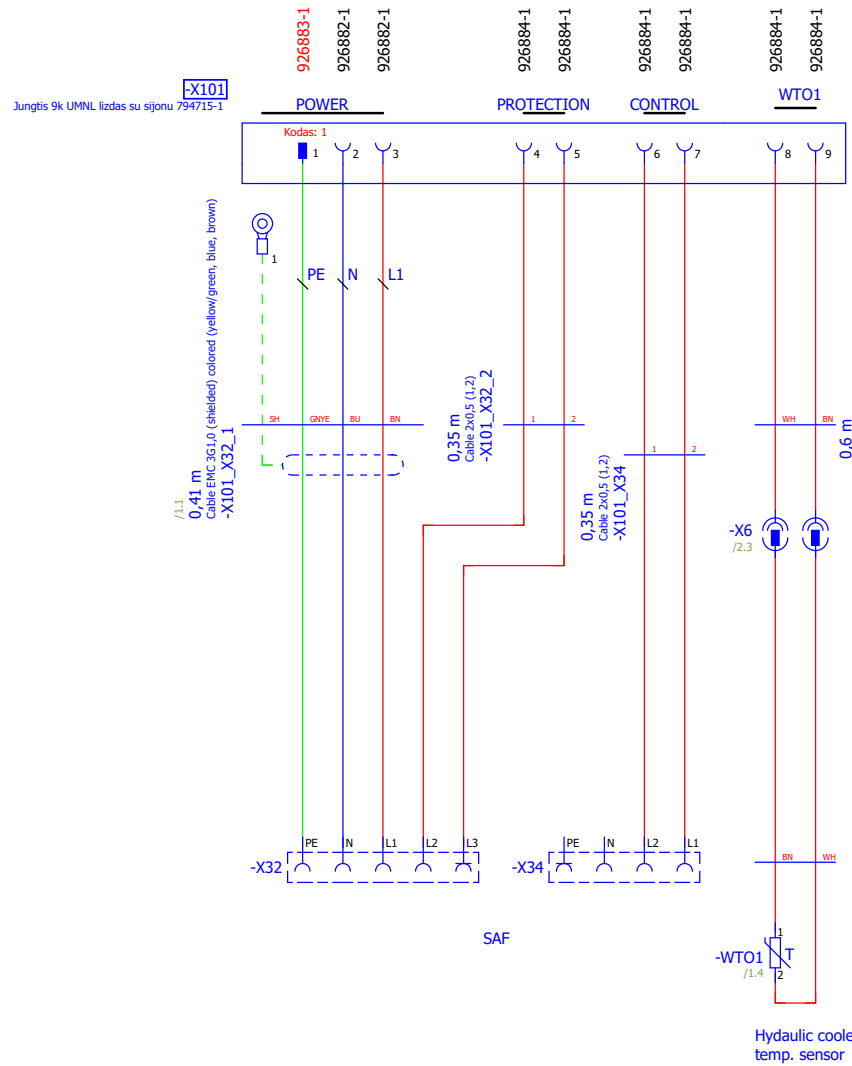

Date	2023-11-21
Ed.	justasbalsys
Appr.	
Modification	Date
	Name
	Original

Harness for AHU	
Replacement of	Replaced by



221.2554.1-PS

= 221.2554	
+	
Project Nr.	Offer nr.
Page	1
Page	1 / 10

Jungtis 9k (UMNL) Izdas su signu /24/7/15-1  
**X103**

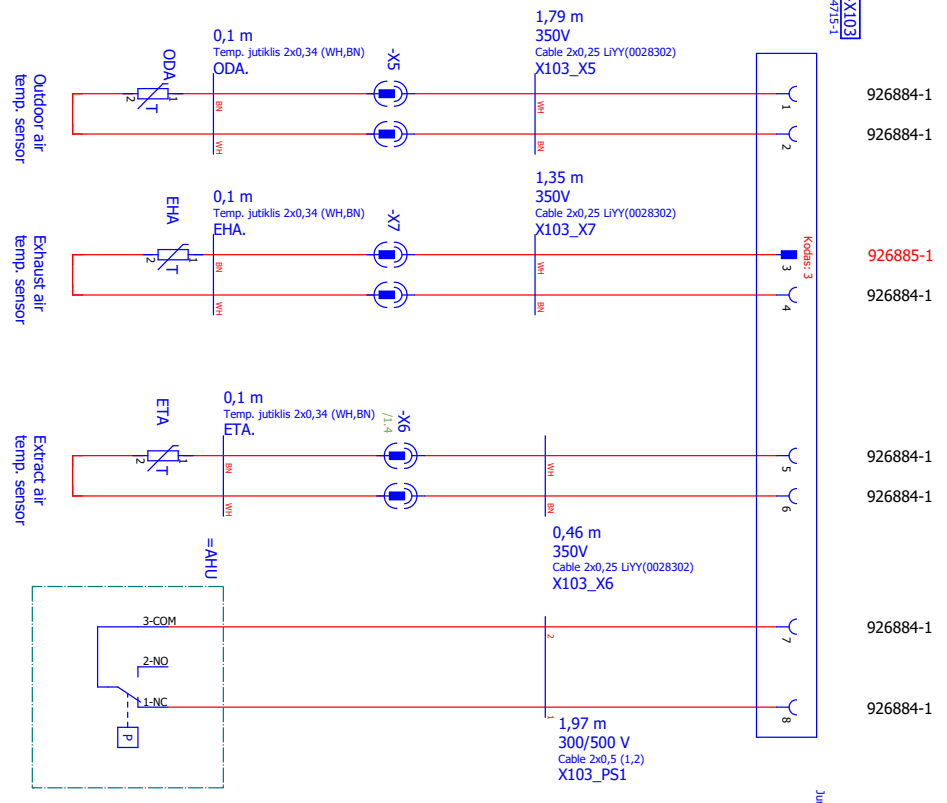

Jungtis 9k (UMNL) Izdas su signu /24/7/15-1  
**X104**

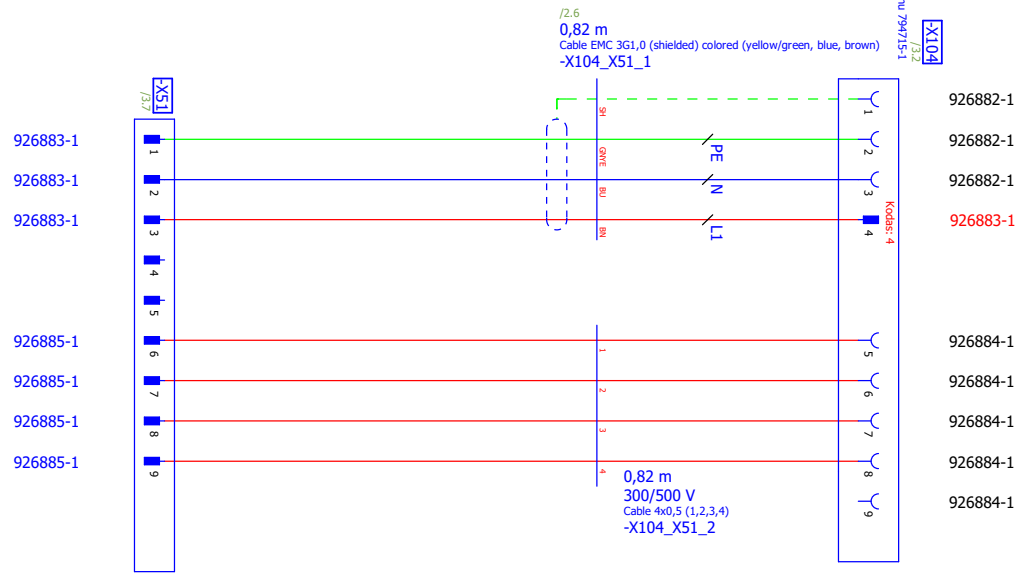

Modification	Date	Name	Date	Ed.	Original	Replacement of	Replaced by
			2023-12-06	Vidas Petrusis		Harness for AHU	



Z21.2554.2-PS

Project Nr.	Offer nr.	Page
		2

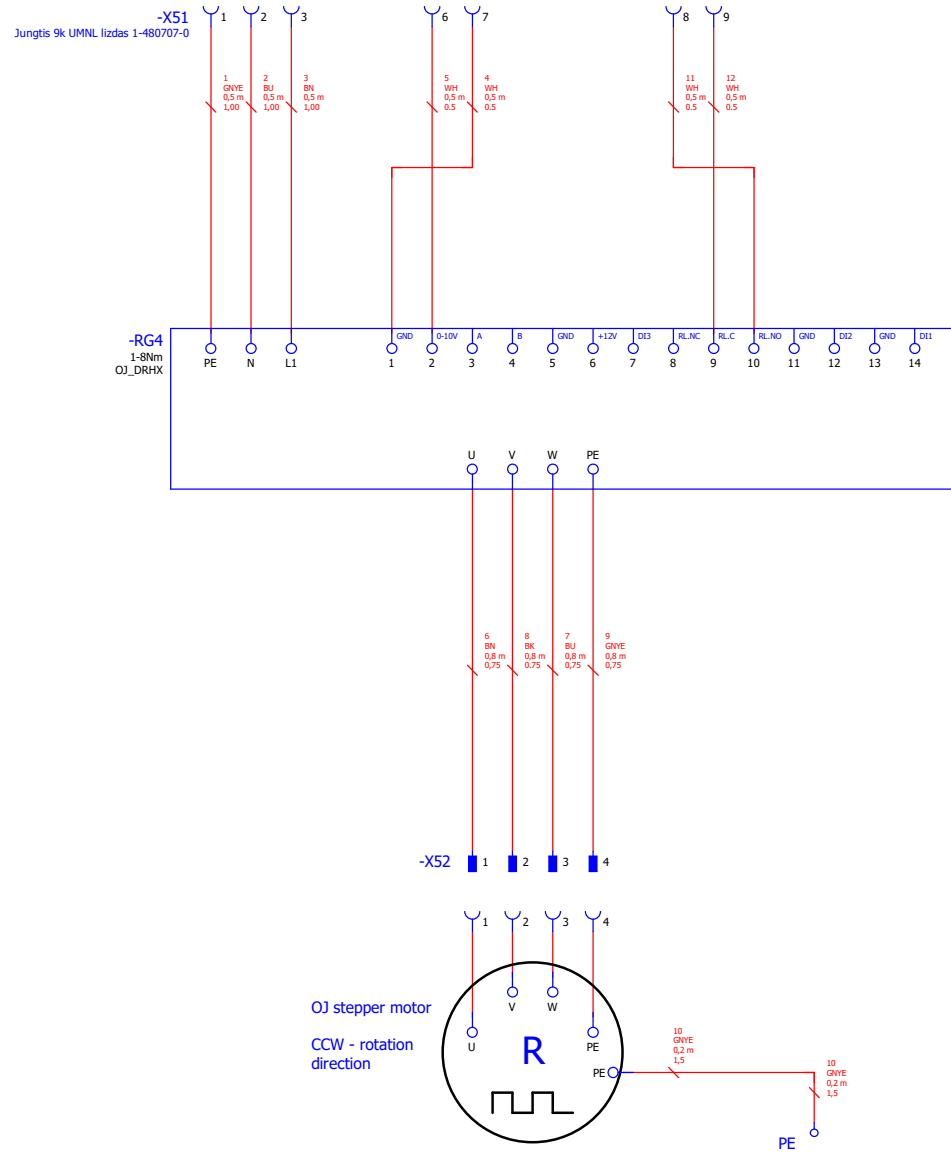

			Date	2023-10-24		221.2189.1-PS	= 221.2189		
			Ed.	justasbalsys			+		
			Appr.				Project Nr.	Offer nr.	Page
Modification	Date	Name	Original		Replacement of	Replaced by		Page	1 / 3

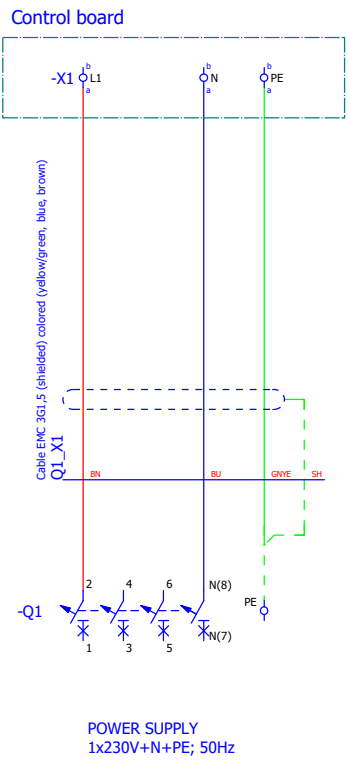

			Date	2023-12-06	SP152		AAC S-R 1000/1500 V main switch connection (1f)	=	+
			Ed.	justasbalsys					
			Appr.						
Modification	Date	Name	Original		Replacement of	Replaced by	Project Nr.	Offer nr.	Page SP152 Page 1 / 1

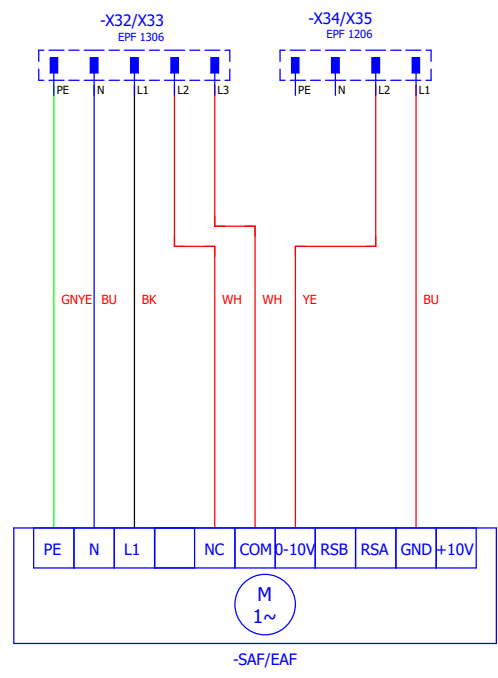



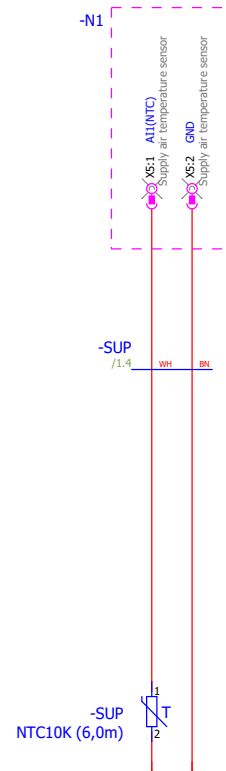

			Date	2023-01-20		
			Ed.	justasbalys		
			Appr.			
Modification	Date	Name	Original	Replacement of	Replaced by	



SUP to MCB

		= SP150 (SUP connection to MCB)	
		+	
Project Nr.	Offer nr.	Page	1
		Page	1 / 1

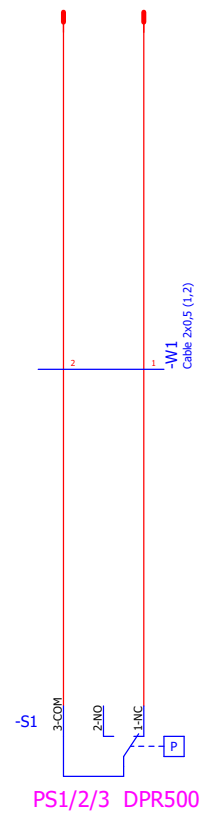
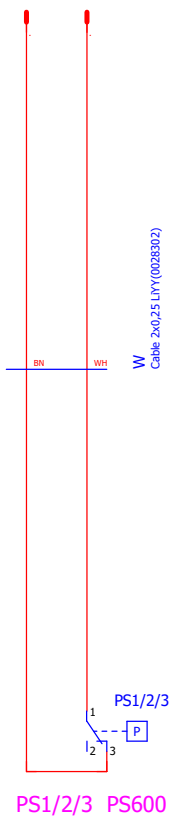

			Date	2023-12-05	SP158
			Ed.	Vidas.Petruitis	
			Appr.		
Modification	Date	Name	Original	Replacement of	Replaced by



PS1/2/3 connection to harness (MCB)

		=
		+
Project Nr.	Offer nr.	Page SP158
		Page 1 / 1