



MCB

EN TECHNICAL MANUAL

 **SALDA**

www.salda.it

1. CONTENT

1. CONTENT	2
2. GENERAL	4
3. SAFETY INSTRUCTIONS AND ALARMS	4
3.1. DANGER	4
3.2. ALARMS	4
4. TRANSPORTATION AND STORAGE RULES	4
5. FUNCTIONAL DESCRIPTION	4
5.1. SYSTEM MODES	4
5.2. SYSTEM CONTROL	5
5.3. SYSTEM STATES	5
5.4. INDICATIONS OF FUNCTIONS, ALARMS AND WARNINGS	6
5.5. SETTING DATE AND TIME	6
5.6. WEEKLY SCHEDULE	6
5.7. HOLIDAY SCHEDULE	6
5.8. WINTER/SUMMER MODE	7
5.9. BOOST FUNCTION	7
5.10. HUMIDITY CONTROL	7
5.10.1. AIR FLOWS CONTROL ACCORDING TO EXTRACT AIR HUMIDITY	7
5.10.2. DRYNESS PROTECTION	7
5.11. NIGHT COOLING FUNCTION	7
5.12. AIR FILTER TIMER	7
5.13. DISPLAY AND CANCELLATION OF ALARMS AND WARNINGS	8
5.14. EVENT LOG (HISTORY)	8
5.15. SYSTEM VERSIONS AND RUNNING TIME	8
5.16. AIR FLOW ADJUSTMENT	9
5.17. PID CONTROLLER ADJUSTMENT	9
5.18. MANUAL CONTROL OF COMPONENTS	9
5.19. SYSTEM MONITORING	9
5.20. MODULE IDENTIFICATION	9
5.21. STAND-BY MODE BLOCKING	9
5.22. AUTOMATIC CANCELLATION OF FAILURE WARNINGS	9
5.23. SUPPLY AIR TEMPERATURE CONTROL AND COMPENSATION	10
5.24. SUPPLY AIR TEMPERATURE LIMITS	10
5.25. CHANGING OF TEMPERATURE SETTINGS ACCORDING TO HEATING SEASON	10
5.26. THE SYSTEM MODE COMMUNICATION WITH EXTERNAL CONTACTOR	10
5.27. FAN SPEED DEPENDENCE ON EXTERNAL CONTACTOR	10
5.27.1. FIREPLACE FUNCTION	11
5.28. FILTER PROTECTION	11
5.28.1. FILTER TIMER SETTINGS	11
5.28.2. AIR FILTER PROTECTION BASED ON PRESSURE SWITCHES	11
5.29. FIRE PROTECTION FROM AN EXTERNAL CONTACTOR	11
5.30. CO ₂ REDUCTION FUNCTION	11
5.31. CHANGING PASSWORDS	11
5.32. RESTORING FACTORY DEFAULTS	11
5.33. FAN CONTROL	12
5.33.1. FAN PROTECTION BY ROTATING SPEED	12
5.33.2. AIR FLOW PROTECTION BASED ON PRESSURE	12
5.33.3. PROTECTION OF PREMISES WITH FIREPLACES	12
5.33.4. SLOWING DOWN AIR-FLOWS BASED ON TEMPERATURE	12
5.33.5. CONTINUOUS TEMPERATURE MAINTAINING BY SLOWING DOWN THE FANS	12
5.33.6. THE MINIMAL OUTDOOR AIR TEMPERATURE OF THE FREON COOLER/HEATER	12
5.33.7. EXHAUST AIR FAN CONTROL ACCORDING TO THE SUPPLY AIR FAN	12
5.34. CONTROL OF DAMPERS	13
5.34.1. RECIRCULATION BASED ON SUPPLY AIR TEMPERATURE	13
5.34.2. FULL RECIRCULATION FUNCTION	13
5.34.3. OUTDOOR AND SUPPLY AIR RECIRCULATION DAMPERS	13
5.34.4. TESTING OF FIRE DAMPERS	14
5.35. HEAT EXCHANGER CONTROL	14
5.35.1. COLD-HEAT RECOVERY	14
5.35.2. HEAT EXCHANGER FROST PROTECTION	14
5.35.3. PROTECTION FROM TOO HIGH CONDENSATE LEVEL	15
5.35.4. INDICATION OF BYPASS DAMPER FAULT	15
5.36. HEATERS	16

5.36.1. SUPPLY AIR HEATER	16
5.36.2. ELECTRIC HEATER OVERHEAT PROTECTION	16
5.36.3. COOLING OF ELECTRIC HEATERS	16
5.36.4. WATER HEATER FROST PROTECTION	16
5.36.5. PROTECTION OF WATER HEATER CIRCULATION PUMPS	16
5.36.6. OUTDOOR AIR PRE-HEATER	16
5.36.7. OUTDOOR AIR WATER PRE-HEATER FROST PROTECTION	17
5.37. COOLERS	17
5.37.1. WATER COOLER	17
5.37.2. FREON COOLER	17
5.37.3. THE MINIMAL OUTDOOR AIR TEMPERATURE OF THE FREON COOLER/HEATER	17
5.37.4. THE FREON COOLER/HEATER AIR FLOW PROTECTION	17
5.37.5. AUTOMATIC ADJUSTMENT OF DEFROST INTERVALS OF THE FREON COOLER/HEATER	17
5.38. DIGITAL INPUT CONFIGURATION	17
5.39. SENSOR CONFIGURATION	18
5.39.1. SENSORS ADJUSTING	18
5.39.2. MODBUS SENSORS	18
5.39.3. PRESSURE LIMITS TO EACH MODE	18
5.40. COMMUNICATIONS LINE CONFIGURATION	18
5.41. CONFIGURATION OF MODULES	19
5.42. COOKING HOOD FAILURE INDICATION	19
5.43. CONTROLLER BOX TEMPERATURE MAINTAINING	19
5.44. LOG-IN SESSIONS ARE LIMITED BY A TIME INTERVAL	19
6. CONNECTION OF BOARD DIAGRAM AND PERIPHERALS	20
6.1. MCB, EX1 AND EX2 CONTROLLER'S I/O LIST	20
6.2. CONNECTION OF MCB MAIN BOARD	24
6.2.1. CONNECTION OF FDI_TACHO INPUTS (MCB)	25
6.2.2. CONNECTION OF HOLO_IN (MCB)	25
6.2.3. CONNECTION OF DIGITAL INPUTS (DI) (MCB)	25
6.2.4. CONNECTION OF TEMPERATURE-ANALOGUE INPUTS (AI NTC) (MCB)	25
6.2.5. CONNECTION OF ANALOGUE 0-10V (AI 0-10 V) INPUT (MCB)	25
6.2.6. CONNECTION AND CONFIGURATION OF RS422/485 COMMUNICATIONS (MCB)	25
6.2.7. CONNECTION OF RS485 COMMUNICATIONS (MCB)	26
6.2.8. CONNECTION OF RECIRCULATION DAMPER (RECIRCULATION ACTUATOR) (MCB)	26
6.2.9. CONNECTION OF BYPASS DAMPER (BYPASS ACTUATOR) (MCB)	26
6.2.10. CONNECTION OF WATER HEATER VALVE (WATER HEATER ACTUATOR) (MCB)	26
6.2.11. CONNECTION OF BYPASS STEPPER DAMPER (BYPASS STEPPER MOTOR) (MCB)	26
6.2.12. CONNECTION OF ANALOGUE OUTPUTS (AO 0-10 V) (MCB)	26
6.2.13. CONNECTION OF POWER SUPPLY SOURCE (MCB)	27
6.3. CONNECTION OF MCB EX1 BOARD	28
6.3.1. POWER SUPPLY TO WATER PRE-HEATER AND COOLER DAMPER (EX1)	28
6.3.2. DIGITAL INPUTS (DI) (EX1)	28
6.3.3. ANALOGUE 0-10V OUTPUTS (AO (0-10 V)) (EX1)	29
6.3.4. CONNECTION OF STEPPER RECIRCULATION ACTUATOR (EX1)	29
6.3.5. CONNECTION OF INDICATION OUTPUTS (WORKING INDICATION, ALARM INDICATION) (EX1)	29
6.3.6. POWER SUPPLY CONNECTION TO AIR QUALITY SENSOR (5VDC) (EX1)	29
6.3.7. CONNECTION OF ANALOGUE 0-10V INPUTS (AI (0-10 V)) (EX1)	29
6.3.8. CONNECTION OF ANALOGUE NTC INPUTS (AI (NTC)) (EX1)	29
6.3.9. POWER SUPPLY CONNECTION TO AIR QUALITY SENSORS (24VCD) (EX1)	30
6.4. CONNECTION OF MCB EX2 BOARD	30
6.4.1. CONNECTION OF FIRE DAMPERS (EX2)	31
6.4.2. CONNECTION OF WATER COOLER CIRCULATION PUMP (EX2)	31
6.4.3. CONNECTION OF CONTROL PANEL HEATER/FAN (EX2)	31
6.4.4. CONNECTION OF AIR DAMPERS (EX2)	31
6.4.5. CONNECTION OF ROTOR MOTOR (EX2)	32
6.4.6. POWER SUPPLY CONNECTION TO TERMINALS X32-X36 AND X39 (EX2)	32
6.4.7. POWER SUPPLY/CONTROL CONNECTION TO ELECTRIC/WATER HEATER OR CONNECTION OF CIRCULATION PUMP (EX2)	32
6.4.8. POWER SUPPLY CONNECTION TO FREON COOLER (EX2)	32
6.4.9. CONNECTION OF REVERSE CONTROL TO FREON COOLER (EX2)	33
6.4.10. POWER SUPPLY CONNECTION TO PRE-HEATER/CONNECTION OF CIRCULATION PUMP (EX2)	33
6.4.11. POWER SUPPLY CONNECTION TO TERMINAL X42 (EX2)	33
6.4.12. POWER SUPPLY CONNECTION TO SUPPLIED/EXHAUSTED AIR FANS (EX2)	33
6.4.13. POWER SUPPLY CONNECTION TO TERMINALS X44 AND X45 (EX2)	33
6.5. CONDUCTORS MAXIMUM CROSS-SECTIONS	34

2. GENERAL

This manual, dedicated to qualified ventilation or electronics specialists, describes functions, configuration and installation of MCB boards to be mounted into air handling units (AHU).

MCB control board consists of the following

- › controller MCB (MCB) + controller MCB (EX1) + controller MCB (EX2).

The MCB control board to be mounted to SMARTY 2RV/2RV plus consists of the following

- › controller MCB (REV_C).

3. SAFETY INSTRUCTIONS AND ALARMS

Prior to installation and use of the unit, please read this Manual carefully. Installation, connection and maintenance shall be executed by a qualified specialist considering the local rules, normative acts and practice.

Prior to connecting peripherals to the board, please read the Manual.

The company shall take no responsibility for the injuries or damaged property if the safety requirements are not followed or the device is modified without the permission of the manufacturer.

3.1. DANGER

Prior to execution of any electrical or maintenance works make sure the product is disconnected from power supply network.

- › If any liquids on electric parts or connections that bear voltage are noticed, stop the operation of the device.
- › Do not plug the device into the mains that differ from the one indicated on the label or on the housing.
- › Voltage of the mains should comply with the electrotechnical parameters indicated on the label.

Based on the Rules for Installation of Electrical Facilities the product shall be grounded. It is forbidden to plug in and operate it non-grounded.

3.2. ALARMS

Connection of electricity and maintenance of the device should be performed by qualified personnel only and in accordance with the manufacturer's instructions and safety requirements.

- › In order to reduce the risk during installation and maintenance, suitable protective clothing must be worn.
- › Electrical power to power mains must be connected via appropriate rating circuit-breaker.

4. TRANSPORTATION AND STORAGE RULES

Automation boards MCB produced by *Salda UAB* shall be transported and stored by following the following rules:

- › Components on the boards are easily vulnerable, therefore it is necessary to protect them against mechanical impact – shocks, crushing, compression, etc.;
- › The boards shall be transported only in rigid cardboard package, wrapped into anti-static bubble film, protecting against mechanical impact;
- › Storage temperature shall be 5-40 °C;
- › Storage relative humidity – <70 %; non-condensing;
- › It is necessary to avoid entrance of dust and other foreign matter on the boards;
- › Only packed boards shall be stored;
- › Package shall be protected against direct sunlight;
- › After the automation boards are unpacked, they shall be checked for damage during transportation. It is forbidden to install damaged units!!!
- › Upon unloading and warehousing the automation boards use the appropriate hoisting equipment to avoid damage and injuries. The units must not be lifted by holding them by the power cords, connection boxes and automation components.

5. FUNCTIONAL DESCRIPTION

The software installed in the control board includes all the functions indicated in this section, however the unit operation and control depends on the following:

- › Selected remote control panel - all functionality and possibility of configuration is ensured only by MB-Gateway web interface;
- › Connected accessories: heaters, dampers, transmitters, etc. (refer to description of purchased ventilation system);
- › Internal unit components: heat exchanger type (plate or rotary one), integrated dampers, transmitters, etc. (refer to section about the selected product components);
- › Type of control board - different boards enable connection of other type components (refer to product board diagram).

5.1. SYSTEM MODES

- › Stand-by;
- › Building protection;
- › Economy;
- › Comfort.



In *Stand-by mode* the system is shut down for a permissible period (based on the Stand-by mode blocking function settings).



The Building protection mode is designed to protect premises against moisture accumulation. The system operates at speed 1. Based on manufacturer's parameters (by default) this mode controls the temperature (the desirable one is indicated), but, if necessary, it can be switched off, i.e. to activate the energy saving mode. Also, if necessary, full recirculation function is activated. (ADJUSTER › USER SETTINGS › BUILDING PROTECTION MODE TEMPERATURE or USER › MENU › SETTINGS › BUILDING PROTECTION).

After activating the energy saving mode, temperature is maintained only by the heat exchanger. It will seek to maintain the current temperature in the room; however, if the supply air temperature falls below the minimal supply air temperature level, heaters will be activated and they will maintain a temperature one degree above the minimum. Also, if the supply air temperature rises above the maximal supply air temperature level, coolers will be activated and they will maintain a temperature one degree below the maximum.



Economy mode is designed to save energy when people are absent from the premises. The system operates at speed 2. Based on manufacturer's parameters this mode controls the temperature maintaining (the desirable one is indicated), but, if necessary, it can be switched off, i.e. to activate the energy saving mode. Also full recirculation function is activated. (ADJUSTER › USER SETTINGS › ECONOMY MODE TEMPERATURE or USER › MENU › SETTINGS › ECONOMY MODE).



Comfort mode is running when people are present in the premises. The system operates at speed 3. In this mode the temperature is always maintained – it is set in the main window (ADJUSTER › VENTILATION CONTROL or USER › SET POINT).

In each of these modes, a fixed position for the recirculation dampers can be set (ADJUSTER › USER SETTINGS › FIXED RECIRCULATION POSITION).

5.2. SYSTEM CONTROL

System modes are changed by the following functions (indicated in a sequential order):

- › Weekly Schedule;
- › Switching on is activated from an external contactor;
- › Manual mode selection;
- › Holiday Schedule;
- › Stand-by mode blocking.

Based on the Weekly Schedule the system decides in what mode it will be operating; however, the user may change it manually. The system informs when the next mode change is scheduled. After power loss the mode is selected based on the Weekly Schedule; however, if it is not set, the mode that was set before the power loss will be activated.

The user may change modes even when the switching on is activated from an external contactor. The only case when it is not possible – active period of Holiday Schedule of which the system informs and which must be changed to avoid blocking.

Stand-by mode can be blocked by selected parameters. If at least one of the above functions changes its mode into Stand-by mode, it must be checked whether this mode is not currently blocked. If it is blocked, the previous mode shall be activated.

The function order is provided below.

START >

- › READING OF INPUT DATA;
- › WEEKLY SCHEDULE;
- › MODE EXTERNAL SWITCH;
- › USER ENTERED DATA;
- › HOLIDAY SCHEDULE;
- › STAND-BY MODE SCHEDULE;
- › STAND-BY MODE BLOCKING;
- › PROTECTION AGAINST DRYNESS;
- › BOOST VENTILATION;
- › AIR HANDLING UNIT OPERATING ALGORITHM;
- › PROTECTION;
- › BLOCKING OF AIR HANDLING UNIT OPERATING ALGORITHM;
- › MANUAL CONTROL OF COMPONENTS;
- › DATA ENTERING INTO OUTPUTS AND USER ENVIRONMENT.

END <

5.3. SYSTEM STATES













This field informs a user about the existing system state. It is displayed in the main window ADJUSTER › VENTILATION CONTROL or the main window of the user environment. The table below shows possible system states.

SYSTEM STATE	DESCRIPTION
Stand-by mode	System operates in Stand-by mode.
Building protection mode	System operates in Building protection mode
Economy mode	System operates in Economy mode
Comfort mode	System operates in comfort mode
Emergency run	System operates in emergency mode (for details refer to alarms section)
Preparing	System is preparing for operation (pre-heating of water heaters, etc.)
Opening dampers	Dampers are opened
BOOST function activated	BOOST function is active
Cooling heaters	Electric heaters are cooled down prior to shutdown of fans

SYSTEM STATE	DESCRIPTION
Closing dampers	Dampers are closed
Night cooling	Active night cooling
Critical alarm	Critical failure, system is shut down (for details refer to alarms section)
Fire alarm	Fire protection from an external contactor is activated
Heat exchanger frost protection activated	Heat exchanger frost protection is activated
Change filters	Warning about clogged filters (pressure switches are activated or filter timer is activated)
Room RH 3 days average is lower than 30%. Limiting speed.	Reduced airflow because of too low exhaust air moisture
DX cooler defrosting	Dissolving the DX cooler / heater
Fire damper testing	Checking fire dampers

5.4. INDICATIONS OF FUNCTIONS, ALARMS AND WARNINGS

User about active functions, warnings or alarms is notified in the window **ADJUSTER › ALARMS** or **USER › ALERT**. Functions are displayed in the main window **ADJUSTER › VENTILATION CONTROL** or in the user environment window. The table below provides indications and their descriptions.

FUNCTIONS	DESCRIPTION
 Working indication output	Working indication output is activated
 Alarm indication output	Failure indication output is activated
 System mode switch	Switching on from an external contactor is activated
 Custom fans speed switch	Selected fans speed from an external contactor is activated
 Winter	Winter mode is active
 Stand-by mode blocking activated	Stand-by mode blocking is activated
 Slowing down fans	Fans are slowed down
 Slowing down fans by temperature	Fans are slowed down depending on supply air temperature
 Night cooling function activated	Night cooling function is activated
 Hydronic pump exercise activated	Preventive maintenance of circulation pumps is activated
 Service stop function	Blocking of air handling unit operating algorithm; Service activities are carried out
 Holidays	Holiday Schedule interval is active. System mode can be changed only upon changing the Holiday Schedule interval
 Reducing CO ₂ level	CO ₂ reduction function is activated
 Full recirculation	Full recirculation function is activated

5.5. SETTING DATE AND TIME

For smooth execution of schedules, event log and winter/summer function, it is necessary to set proper date and time in section **ADJUSTER › USER SETTINGS › DATE AND TIME SET** and click a button **DATE AND TIME SET**. It can also be indicated in user environment **USER › MENU › SETTINGS › DATE AND TIME**. Fast synchronization with the computer time is possible in user and adjuster environment.

5.6. WEEKLY SCHEDULE

A weekly schedule consists of 10 weekly events. They can be added, deleted, activated and deactivated. One event indicates time, mode/BOOST function, days of the week. Also it is possible to indicate the change of settable mode temperature. The system changes modes according to the Weekly Schedule only when the indicated time comes, therefore a user can always change the existing mode manually. This schedule notifies of the upcoming mode change by indicating the time remaining till the next event. The schedule is edited in user environment **USER › MENU › SCHEDULE**.

5.7. HOLIDAY SCHEDULE

This schedule is used when the unit has to operate in uniform mode during holidays. The user interface shows when the schedule period is active as nobody can change the mode activated by this function (except for protection). In order to control the system in a normal manner, the Holiday Schedule period must be deactivated, i. e. zero values must be indicated or dates must be changed. Up to five holiday periods can be set. The schedule is edited in the user environment **USER › MENU › HOLIDAY**.

5.8. WINTER/SUMMER MODE

The winter/summer function is set during the cold periods, because some parts of the system have to be protected against cold outdoor air. During winter it is recommended to leave the unit switched on, therefore it is possible to set blocking of switch-off. Water heaters must be always switched on during the entire winter.

The winter mode may be indicated

- › Manually;
- › By date;
- › Based on 3-day mean outdoor temperature, to be calculated only when the fresh air (outdoor) pre-heater is off.

5.9. BOOST FUNCTION

Boost ventilation function is used for fast ventilation of premises. It activates the maximum air-flow (speed 4). Boost ventilation has to be temporary, i.e. it must be a final condition (e.g. CO₂ limit, time). The reason for this limitation – protection against dryness. High air flow reduces humidity, and dry air is harmful for health.

The function is activated by pressing **ON** and deactivated by pressing **OFF** button in the **BOOST** section, or by means of an external contactor (**FANS SPEED SWITCH**), which is configured in the service environment (**SERVICE › MAIN › FANS SPEED SWITCH**) section.

The function is inactive when Stand-by mode is on. Time limit is indicated (**ADJUSTER › USER SETTINGS › BOOST TIMER** or **USER › MENU › SETTINGS › BOOST TIMER**). Once the function is activated, the time is set by the timer and the time is counted till its deactivation. It may be adjusted in real-time, i.e. when the function is on, in **ADJUSTER › VENTILATION CONTROL** or in the user environment main window.

5.10. HUMIDITY CONTROL

5.10.1. AIR FLOWS CONTROL ACCORDING TO EXTRACT AIR HUMIDITY

When this function is turned on, the winter and summer humidity limits are indicated. If the 3-day average value of extract air humidity exceeds the set limit, the air flow is increased by one speed and the moment humidity rise is set on the basis of the 3-day average value. Otherwise, the moment humidity rise is established according to the set limit.

If the moment extract air humidity exceeds the set limit by more than 10 % for more than 5 minutes, then the moisture excess removal (intensive ventilation) is activated for the specified time period (30 minutes).

5.10.2. DRYNESS PROTECTION

This function is designed to protect premises against dryness. If the function is active, it calculates the 3-day mean humidity of extract air from the premises. If the mean drops below set limit (30 %), fans start operating in speed 2 in comfort mode. A user is notified of the activated protection and limited air flow.

If the humidity mean exceeds set limit (30 %) or the function is switched off manually, fans start operating in speed 3 in comfort mode.

The function is switched on/off in the section **ADJUSTER › USER SETTINGS › DRYNESS PROTECTION** or in the window **USER › MENU › SETTINGS › OTHER**.

5.11. NIGHT COOLING FUNCTION

This function is designed to save energy in the morning, when a fresh night air is used to cool down the building. The function is active only in summer. If it is switched on but not active yet, activation conditions are checked:

- › System time from function start to the end (hours/minutes);
- › Time is exactly every hour since the start;
- › If **STAND-BY MODE** is set, the unit operates in **BUILDING PROTECTION MODE** for 5 minutes so that the actual temperature data is available. The temperature is checked after purging. If it is not suitable, the unit returns to **STAND-BY MODE**;
- › Outdoor temperature is higher than the set outdoor temperature;
- › Exhaust air temperature is higher than the set temperature;
- › Exhaust air temperature is higher than the outdoor temperature by at least 2 °C;
- › Summer.

If all conditions are met the unit starts operating in **COMFORT MODE** (without temperature maintaining). The main window shows that the Night cooling function is active. When it is active continuously, the deactivation conditions are checked:

- › Time does not correspond to the start/end interval;
- › Exhaust air temperature drops below the set temperature;
- › Outdoor temperature drops below the set temperature;
- › Mode other than **COMFORT** was switched or the unit has been shut down.

If at least one condition is met, the unit switches off the Night cooling function and it switches to the mode that was on prior to activating the function. The function is configured in the section **ADJUSTER › USER SETTINGS › NIGHT COOLING FUNCTION** or in the window **USER › MENU › SETTINGS › NIGHT COOLINGS**.

5.12. AIR FILTER TIMER

The air filter timer indicates to the user when the filters are clogged. After their replacement, the timer must be reset. The user can always see how many days are left till the filter replacement. The timer limit can be set in the service environment. Maximum permissible time – 1 year. It is calculated only when the fans are rotating.

The filter timer can be reviewed and reset in the section **ADJUSTER › USER SETTINGS › FILTERS TIMER** or in the window **USER › MENU › SETTINGS › FILTERS TIMER**.

The time limit is indicated in the service environment **SERVICE › MAIN › AIR FILTERS PROTECTIONS**.

5.13. DISPLAY AND CANCELLATION OF ALARMS AND WARNINGS

The system notifies the user about the system failures by warnings that are canceled automatically and by alarms that have to be canceled manually. The latter are recommended to be canceled by a specialist prior to finding out the causes of the alarm. Information on alarms and warnings is also displayed in the main window **ADJUSTER** › **VENTILATION CONTROL**. If at least one alarm is active, the system is shut down and external failure indication is activated. Alarms and warnings can be reviewed and canceled in the window **ADJUSTER** › **ALARMS** or **USER** › **ALERT**. All possible alarms and warnings are provided in the table below.

INDICATION	ALARMS LIST	INDICATION	ALARMS LIST
W.01	Warning! Rotor broken belt alarm.	A.31	Alarm! Controller cabinet temperature sensor failure. System stopped.
A.02	Alarm! Fireplace protection activated.	W.32	Fire damper test OK.
W.03	Warning! Dryness protection activated.	W.33	Warning! Fire damper test failed.
W.04	Warning! Plate heat exchanger frost protection activated.	A.34	Alarm! Heater manual protection. System stopped!
A.05	Alarm! Plate heat exchanger frost protection system stopped.	W.35	Warning! Heater automatic protection.
W.06	Warning! Plate heat exchanger frost protection (pressure relay).	A.36	Alarm! Pre-heater manual protection. System stopped!
A.07	Alarm! Hydronic heater frost protection. System stopped.	W.37	Warning! Pre-heater automatic protection.
W.08	Warning! Too low supply temperature.	A.38	Alarm! Supply fan failure.
W.09	Warning! Too high supply temperature.	A.39	Alarm! Extract fan failure.
A.10	Alarm! Too low supply temperature. System stopped.	W.40	Warning! DX cooler failure.
A.11	Alarm! Too high supply temperature. System stopped.	A.41	Alarm! Fire.
W.12	Warning! Change supply air filter (pressure relay).	A.42	Alarm! Supply fan pressure protection. System stopped.
W.13	Warning! Change extract air filter (pressure relay).	A.43	Alarm! Extract fan pressure protection. System stopped.
W.14	Warning! Change supply and extract filters (time-out).	A.44	Alarm! Internal system error.
A.15	Alarm! Power supply failure. Please, check F1 fuse.	A.45	Alarm! Heater manual protection. Boosting.
W.16	Warning! Supply air temperature sensor failure. Emergency run.	A.46	Alarm! Pre-heater manual protection. Boosting.
W.17	Warning! Extract air temperature sensor failure. Emergency run.	A.47	Alarm! Internal communication error.
W.18	Warning! Exhaust air temperature sensor failure. Emergency run.	W.48	Warning! DX cooler defrosting.
W.19	Warning! Outdoor air temperature sensor failure. Emergency run.	W.49	Warning! Too high 3 days extract humidity. Increasing air flow.
W.20	Warning! Hydronic heater water temperature sensor failure. Emergency run.	W.50	Warning! Too high extract humidity. Boosting.
W.21	Warning! Hydronic pre-heater water temperature sensor failure. Emergency run.	A.51	Alarm! Rotor broken belt alarm. System stopped.
W.22	Warning! Hydronic cooler water temperature sensor failure. Emergency run.	W.52	Warning! Gas heater failure.
W.23	Warning! Controller cabinet temperature sensor failure. Emergency run.	W.53	Warning! Gas pre-heater failure.
A.24	Alarm! Supply air temperature sensor failure. System stopped.	W.54	Warning! Too high condensation level.
A.25	Alarm! Extract air temperature sensor failure. System stopped.	W.55	Warning! Supply fan failure. Emergency run.
A.26	Alarm! Exhaust air temperature sensor failure. System stopped.	W.56	Warning! Extract fan failure. Emergency run.
A.27	Alarm! Outdoor air temperature sensor failure. System stopped.	W.57	Warning! Too low supply air flow for DX cooler.
A.28	Alarm! Hydronic heater water temperature sensor failure. System stopped.	A.58	Alarm! Bypass damper failure. System stopped.
A.29	Alarm! Hydronic pre-heater water temperature sensor failure. System stopped.	A.59	Alarm! Hydronic heater/pre-heater circ. pump failure. System stopped.
A.30	Alarm! Hydronic cooler water temperature sensor failure. System stopped.	W.60	Warning! Hydronic heater/pre-heater circ. pump failure.

5.14. EVENT LOG (HISTORY)

The system records 50 recent events (failures, alarms, fire damper testing results, etc.). The log stores the description of events and time. The event log may be reviewed in the window **ADJUSTER** › **HISTORY** or **USER** › **MENU** › **HISTORY**.

5.15. SYSTEM VERSIONS AND RUNNING TIME

In the section **ADJUSTER** › **USER SETTINGS** › **ABOUT** you may see software and configuration versions that are saved in the production line namely to every unit. Next to them the running time since the unit has been manufactured is also displayed. It is calculated when the fans are rotating.

5.16. AIR FLOW ADJUSTMENT

Air-flows are adjusted in the adjuster environment window **ADJUSTER › AIR FLOWS ADJUSTING**. There are 4 of them in the system and they are dedicated to specific mode:

- › Building protection;
- › Economy;
- › Comfort;
- › Maximum power (**BOOST FUNCTION**).

Air-flows are arranged in an ascending order, i.e. upon setting lower air-flow in **COMFORT MODE** than in **ECONOMY MODE**, the air-flow of the latter is reduced automatically. With respect to the system configuration, air-flows are indicated in percentage, pressure or amounts of air. 100 % value of air-flow is indicated in service environment window **SERVICE › FANS › FAN SPEED CONTROL**.

5.17. PID CONTROLLER ADJUSTMENT

In the adjuster environment window **ADJUSTER › PID CONTROLLERS ADJUSTING** the coefficients of the existing PID controllers are adjusted. The amount depends on the system configuration. If the system operation for any reasons is unstable (fluctuating), PID coefficients may be adjusted. It is recommended that a specialist did this.

5.18. MANUAL CONTROL OF COMPONENTS

This function manually activates/deactivates the components controlled by digital and analogue outputs. The latter ones are controlled in percentage, and digital ones – by **ON/OFF**. Based on manufacturer's parameters (by default) the status of all components is **AUTO**, which means that control is based on air handling unit operating algorithm. Components are displayed by the system configuration. Settings must be saved so they remain active after power loss.

The lowest power consumption is when the Stand-by mode is on, and position of components – **AUTO**.

Prior to using the manual control function, it is recommended to activate the force shutdown function, which blocks the air handling unit operating algorithm.

This can be useful, if you need to check whether everything is properly connected. Moreover, in the event of failure, certain components can be activated so that the unit operates irrespective of sensors and protections. Of course, this method should be applied in exceptional cases until the failure is rectified.

If the service environment window **SERVICE › SENSORS** displays an external (**REMOTE**) type of a temperature sensor, its temperature may be indicated manually. The values may be indicated via the Modbus interface.

5.19. SYSTEM MONITORING

The service and adjuster environment have the window **MONITORING** where you can monitor operation of the entire system, i.e. see controller input and output, CO₂ values, versions of connected modules, date and time, speed of fans, temperatures, pressure, etc. The amount of information depends on the system configuration. This tool is designed for preventive maintenance of the system.

5.20. MODULE IDENTIFICATION

Three expansion modules can be connected to the main MCB board:

- › EX1 module (module to control a heat recovery unit);
- › EX2 module (power module with relays);
- › Communications module.

Every module has its version, thus if it is connected instead of **DISCONNECTED**, a specific version number appears. Module states can be monitored in the service or adjuster environment window **MONITORING**.

5.21. STAND-BY MODE BLOCKING

This function is designed to protect the system against the impermissible unit shutdown and it is recommended to limit the unit shutdown up to 1 hour within 12 hours during the winter season. Possible function modes:

- › Always allow shutdown;
- › Block shutdown;
- › Block shutdown in winter;
- › Block shutdown in summer.

It must be indicated for how long the shutdown is permissible within 12 hours. If it is blocked and the system is shut down, the system counts and informs the user on the remaining time. This function is configured in the service environment (**SERVICE › MAIN › SYSTEM BLOCKING**).

If the time has expired and Stand-by mode is blocked, the user is informed by the function indication.

5.22. AUTOMATIC CANCELLATION OF FAILURE WARNINGS

This function is intended for the automatic elimination of freezing-related breakdowns after a certain period of time. E.g., if the unit was shut down due to critical frost protection conditions, then after some time the system can try operation again. The period is indicated in hours. If 0 is set, the system waits until the user cancels the failures manually.

5.23. SUPPLY AIR TEMPERATURE CONTROL AND COMPENSATION

Temperature for supply air or premises temperature may be indicated. In the service environment section **SERVICE › MAIN › SUPPLY AIR TEMPERATURE CONTROL** you can control it based on supply or exhaust air temperature. If control by premises temperature is selected, then it is calculated what kind of air is to be supplied so that the proper room temperature is maintained. It is limited by allowable limits of supply air temperature.

The air handling unit is not designed to heat premises, therefore it is not necessary to use full capacity for low temperature differences – the compensation in percentage is provided for this purpose. This parameter indicates a percentage of the temperature difference (between the set temperature and premises temperature) to be compensated by this function. E.g. set point is 20 °C, temperature in the premises is 16 °C, compensation is 50 %, difference between the indicated and existing temperatures is 20-16=4 °C. Since 50 % is compensated, then 4*50 %=2 °C. When the received value is added to the set temperature we get the required supply air temperature – 2+20=22 °C. This temperature is not limited as it is within the supply air temperature protection limits. In this case the system maintains the supply air temperature at 22 °C. The closer the premises temperature is to the set temperature (20 °C), the faster the supply air temperature reaches 20 °C.

It may be too hot in the premises, therefore this function both heats and cools. Preferred (compensated) temperature is displayed in the window **MONITORING (REQUIRED SUPPLY)**. If the displayed temperature is 0 °C, it means that temperature maintaining of supply air is switched off.

It is also possible to specify an integration factor that will gradually change the required supply air temperature without reaching the required extract air temperature. The higher the factor, the faster the required supply air temperature changes.

The temperature of supply air is maintained by the following components (indicated in a sequential order):

- › Fans (operate slower, if it is too hot);
- › Recirculation valve (if the ambient air temperature is favourable);
- › Water cooler;
- › DX cooler;
- › Recirculation damper and CO₂ (in case of favourable outdoor temperature);
- › Bypass damper or rotor (in case of favourable outdoor temperature);
- › Recirculation damper and CO₂ (in case of favourable outdoor temperature);
- › DX heater;
- › Water heater;
- › Water cooler/heater;
- › Electrical heater;
- › Fans (operate slower, if it is too cold).

First of all the system tries to maintain the supply air temperature by means of a heat exchanger. In case of a plate heat exchanger, the bypass damper is controlled, and in case of a rotary heat exchanger, the rotor rotating speed or interval is changed. The heat exchanger can both heat and cool – it depends on outdoor and room air temperatures. It is controlled by a PID controller whose coefficients are indicated in the adjuster environment section **ADJUSTER › PID CONTROLLERS ADJUSTING › HEAT EXCHANGER CONTROL BY SUPPLY AIR TEMPERATURE**.

When the heat exchanger operates at full capacity and preferred temperature is not reached, the recirculation damper, then the heater or cooler etc. is activated (if necessary). Only the components configured for temperature maintaining are activated. It takes 10 s for the system to switch between the elements.

5.24. SUPPLY AIR TEMPERATURE LIMITS

In the service environment section **SERVICE › MAIN › SUPPLY AIR TEMPERATURE LIMITS** the minimum and maximum supply air temperatures are indicated as well as permissible time and protection actions (no indication, indication of warning only, or unit shut-down). This function limits the supply air temperature set by the user and other functions. If it is controlled by premises temperature, this function does not allow supplying warmer or cooler air than that indicated in the protection.

If the system fails to maintain the right temperature, i.e. the supply air temperature is outside the protection limits for an indicated time period, the unit is shut down (if indicated) and alarm is displayed. Based on manufacturer set parameters (by default), the minimum permissible supply air temperature is 16,5 °C, and maximum – 40,0 °C.

5.25. CHANGING OF TEMPERATURE SETTINGS ACCORDING TO HEATING SEASON

This function is used to automatically change the temperature settings according to the season. As the heating season changes, the change from heating to cooling is added to the temperature settings for all modes (building protection, economy, comfort) and subtracted when changing from cooling to heating season.

The change can range from -15°C to +15°C. Addition or subtraction is limited by the permissible minimum and maximum supply air temperatures. The default is 0°C, so the temperature settings do not change with the heating season. Function settings in debugger environment in **ADJUSTER › USER SETTINGS › WINTER/SUMMER › TEMPERATURE SETPOINT CORRECTION ON SEASON CHANGE**.

5.26. THE SYSTEM MODE COMMUNICATION WITH EXTERNAL CONTACTOR

This function activates the preferred system switching on by means of external contactor; it indicates what signal will be sent to input. Possible types of signals:

- › Not used;
- › Upon pressing a button the selected system mode is activated. After receipt of the first impulse the function is activated, and after second impulse – deactivated;
- › ON/OFF; selected system mode is activated. The mode is active until the contactor is on;
- › PIR sensor. When the sensor is activated, the selected system mode is activated. If the signal is not received for 30 minutes, the mode is deactivated.

Function is set in the service environment section **SERVICE › MAIN › SYSTEM MODE SWITCH**.

5.27. FAN SPEED DEPENDENCE ON EXTERNAL CONTACTOR

This function is designed to activate/deactivate the boost ventilation or preferred combination of fan speeds by means of an external contactor. It is necessary to indicate a type of a signal to be sent to the input and what this function will control. Possible combinations of signal types and functions:

- › Not used;
- › ON/OFF; selected fan speed combination is activated; the function is active until the contactor is on;
- › Upon pressing a button the selected fan speed combination is activated; upon receipt of one impulse the function is activated, and after second impulse – deactivated;
- › ON/OFF. Boost ventilation function is controlled. It is active until the contactor is on. If this function is not shutdown, after expiry of time limit a boost ventilation is terminated by force.
- › Press a button. Boost ventilation function is controlled. After receipt of one impulse it is activated, and after second impulse – deactivated. If this function is not terminated, after expiry of time limit a boost ventilation is terminated by force.

It is also indicated whether boost ventilation will be activated or a combination of fan speeds is preferred, i.e. it is possible to indicate individually a preferred speed of the supply and exhausted air fans.

Function is set in the service environment section **SERVICE › MAIN › FANS SPEED SWITCH**.

5.27.1. FIREPLACE FUNCTION

The function of fan speed dependence on external contactor may help to light up the fireplace. The external contactor may be connected to its door switch. It must be indicated that **ON/OFF** signal, the minimum exhausted air fan speed and the maximum supplied air fan speed is used. This combination creates the pressure in premises, which improves the flue gas exhaust through a chimney and flame intensity. Upon opening the fireplace door the function is activated and upon closing – deactivated.

Function is set in the service environment section **SERVICE › MAIN › FANS SPEED SWITCH**.

5.28. FILTER PROTECTION

5.28.1. FILTER TIMER SETTINGS

The filter timer limit is set in the service environment window **SERVICE › MAIN › AIR FILTERS PROTECTIONS**. The maximum setting is 1 year.

5.28.2. AIR FILTER PROTECTION BASED ON PRESSURE SWITCHES

Installed pressure switches can protect air filters against clogging. In the service environment window **SERVICE › MAIN** you can indicate their combinations:

- › None;
- › Supply air;
- › Exhaust air;
- › Supply and exhaust air.

When pressure switches are activated, the alarm is displayed.

5.29. FIRE PROTECTION FROM AN EXTERNAL CONTACTOR

Two fire alarms – the main and the auxiliary – can be connected to this controller. According to default factory settings, the input of the master signal is normally closed (NC). Its configuration can be changed in the service environment in section **SERVICE › DIGITAL INPUTS › EXTERNAL CONTROL INPUTS**. The response and the start time are indicated at the signal inputs, i.e. when the input will respond after opening voltage to the automation. If the signal is interrupted, the protection is activated, a message is displayed and the system is operated in the specified mode. If both protections are triggered, the function specified in the main input is performed. Protection is terminated upon cancelling the warning. In the service environment section **SERVICE › MAIN › FIRE PROTECTION** a period of time when the system does not react and the mode of activated protection is indicated:

- › Shut down the system;
- › Run the supplied air fan at full speed and shut down the exhausted air fan;
- › Run the exhausted air fan at full speed and shut down the supplied air fan;
- › Run the supplied and exhausted air fan at full speed.

5.30. CO₂ REDUCTION FUNCTION

This function is designed to maintain a proper quality of room air. To activate it the exhaust air CO₂ sensor must be connected and properly configured in the service environment window **SERVICE › SENSORS**. When completed, the exhaust air CO₂ value is displayed in the section **MONITORING**. In the service environment window **SERVICE › MAIN › CO₂ REDUCTION FUNCTION** you can switch on/off the function, indicate preferred CO₂ level and allowable limit; when it is exceeded (CO₂ set + allowable excess) CO₂ is reduced, information is displayed and air-flow is increased. When CO₂ reaches the set point, reduction is switched OFF.

CO₂ protection is inactive in the stand-by and building protection modes.

5.31. CHANGING PASSWORDS

In the service environment section **SERVICE › MAIN › PASSWORD › PASSWORD CHANGING MODE › ON** you can change login passwords. For this it is necessary to activate the change and after entering a preferred password (4 digits), click a button **SET**. To review and change the parameters without a password, just set **0**.

5.32. RESTORING FACTORY DEFAULTS

If set parameters result in incorrect operation of the system, you can always restore the factory defaults in the service environment window **SERVICE › MAIN › FACTORY SETTINGS**.

5.33. FAN CONTROL

The preferred air-flow can be indicated in percentage or in 4 fixed speeds where each of them is dedicated to a relevant system mode:

- › Building protection;
- › Economy;
- › Comfort;
- › Maximum power.

Fan speed can be controlled by:

- › Percentage - speed in percentage is indicated in the adjuster environment window **ADJUSTER › AIR FLOWS ADJUSTING**: 0 % corresponds to 0, and 100 % – 10 V control signal voltage;
- › Pressure - the maximum system pressure is indicated, which based on speed settings in the adjuster environment **ADJUSTER › AIR FLOWS ADJUSTING** means 100 % air-flow;
- › Air-flow (m³/h) - K factors of supply and exhaust air and the maximum system air-flow (m³/h) are displayed, which based on speed settings in the adjuster environment **ADJUSTER › AIR FLOWS ADJUSTING** means 100 %.

Fans based on air-flow and pressure are controlled by PID controller and its coefficients are indicated in the adjuster environment section **ADJUSTER › PID CONTROLLERS ADJUSTING › FANS SPEED CONTROL BY AIR FLOW OR PRESSURE**. Every fan is controlled individually.

In the service environment window **SERVICE › FANS › FANS SPEED CONTROL** you can limit the minimum and maximum fan control signal voltage. Based on manufacturer set parameters, the minimum 2V voltage is indicated, which means that 0V voltage signal is sent when fans are off, and 2V voltage signal is immediately switched on when rotation is required.

It is possible to specify the nominal flows of supply and exhaust air. Then, the maximal air flow is calculated automatically.

5.33.1. FAN PROTECTION BY ROTATING SPEED

If fans have *TACHO* outputs, the fan failure can be identified by their rotating speed. If the system sends the signal to fans to rotate and they fail to rotate, then the protection is activated, the system is shut down and alarm is displayed.

Function is switched on/off in the service environment section **SERVICE › FANS › FANS PROTECTION BY RPM**.

If this protection is disabled, the same inputs are used for the warning signal, i.e. if the main fan failed and reserve fan is still working, then the signal is transmitted to this input and warning is displayed about fan fault (system is not stopped).

5.33.2. AIR FLOW PROTECTION BASED ON PRESSURE

When this protection is activated the system must reach the required pressure or air-flow. If it does not happen within the indicated period of time, the protection is activated, the unit is shut down and alarm is displayed. This may happen due to air flow/pressure gauge failures, pressure hose defect, clogged flow, impeller defect, incorrect factor K, etc.

Function is switched on/off and time is set in the service environment section **SERVICE › FANS › AIR FLOW PROTECTIONS**.

5.33.3. PROTECTION OF PREMISES WITH FIREPLACES

This protection is used for buildings with fireplaces. It protects against improper differential air pressure, which can result in appearance of flue gas (carbon black). A pressure switch must be connected to a dedicated digital input, which measures differential pressure in premises and inside a chimney. Upon activation of this protection, the unit is shut down by the activated pressure switch and warning is displayed.

Function is switched on/off in the service environment section **SERVICE › FANS › AIR FLOW PROTECTIONS**.

5.33.4. SLOWING DOWN AIR-FLOWS BASED ON TEMPERATURE

If supply air temperature is more important than the air-flow, the slowing down function may be switched on. If full heating/cooling capacity is used, but the preferred temperature is not reached, air-flow starts slowing down to reach the goal.

Function is switched on/off in the service environment section **SERVICE › FANS › AIR FLOW PROTECTIONS**.

5.33.5. CONTINUOUS TEMPERATURE MAINTAINING BY SLOWING DOWN THE FANS

This function helps to save energy, when air-flow is changed. It is active, when the fans are controlled by percentage, since *PID* controllers do it automatically when it is controlled based on air-flow or pressure. Fast change of air-flow imbalances the temperature maintaining function, thus energy is wasted. If a user sets a higher air-flow, this function starts gradually increasing the air-flow and gradually slows down the speed of change when it approaches the set value. This way the temperature maintaining function suffers less stress and consumes less energy. If the user reduces the air-flow, the system switches off the coolers and heaters to prevent from building up of heat/cold wave and gradually changes the air-flow. Afterwards the heaters and coolers continue operating as required.

5.33.6. THE MINIMAL OUTDOOR AIR TEMPERATURE OF THE FREON COOLER/HEATER

The minimal fresh air temperature, at which the DX cooler/heater can operate, is indicated. If the fresh air temperature drops below the specified limit, then the DX cooler/heater is shut down.

5.33.7. EXHAUST AIR FAN CONTROL ACCORDING TO THE SUPPLY AIR FAN

This function can be activate in the column **SERVICE › FANS**. When this function is active, only the percentage/pressure/quantity of the supply air flow are indicated. The exhaust air flow is controlled automatically by maintaining the nominal relation of the air flows. This function requires pressure

transducers, which measure the supply air and exhaust air flows. If MCB inputs are not sufficient, it is possible to use the pressure converters through Modbus communication line. The supply air fan can be controlled by percentage, according to the pressure or flow, while the exhaust air fan is always controlled according to the flow.

5.34. CONTROL OF DAMPERS

The following can be connected to the system:

- › supply air damper (ON/OFF, 3P, OPEN/CLOSE or Spring-return type). It is open to before starting the supply air fan and closed when it is stopped;
- › exhaust air damper (ON/OFF, 3P, OPEN/CLOSE or Spring-return type). It is opened before start-up of the exhaust air fan and closed when it is stopped;
- › recirculation dampers which are used to protect the heat exchanger from freezing, to maintain temperature and for complete recirculation function;
- › Fire dampers with one or two limit switches. They are controlled in the same way as supply/exhaust dampers, except for cases when testing function is active or fire protection is activated.

If ON/OFF, 3P or OPEN/CLOSE type damper is indicated, proper opening time must be indicated. ON/OFF type damper control:

- › When it is necessary to open, *OPEN* signal is activated;
- › It is necessary to wait until it opens and fans are started;
- › *OPEN* signal is activated during the entire operation time;
- › When shutting down the system, it is necessary to wait for 10 s, until the fans stop rotating and switch off the *OPEN* signal.

3P type damper control:

- › When it is necessary to open, *OPEN* signal is activated;
- › Waiting until it opens, *OPEN* signal is switched off and fans are started;
- › *OPEN* and *CLOSE* signals are switched off during the entire operation time;
- › When shutting down the system, it is necessary to wait for 10 s, until the fans stop rotating and activate the *CLOSE* signal for an indicated time period.

OPEN/CLOSE type damper control:

- › When it is necessary to open, *OPEN* and *CLOSE* signals are activated;
- › It is necessary to wait until it opens and fans are started;
- › *OPEN* and *CLOSE* signals are activated during the entire operation time;
- › When shutting down the system, it is necessary to wait for 10 s, until the fans stop rotating and switch off the *OPEN* signal (*CLOSE* remains active) for an indicated time period.

Spring-return type control (with a spring)

- › When opening is required, the *OPEN* signal is activated;
- › wait until it opens, and the fans are activated;
- › *OPEN* signal is on full-time during operation;
- › when the system is being stopped, wait for 10 seconds until the fans stop, and the *OPEN* signal is deactivated, the dampers close immediately.

5.34.1. RECIRCULATION BASED ON SUPPLY AIR TEMPERATURE

This function is designed to maintain the supply air temperature by reducing the volume of unfavorable fresh (outdoor) air. Additionally it is recommended to use CO₂ sensor for the premises air, whereas upon increase of CO₂ the closing level of recirculation damper would be limited. Temperature maintaining is controlled only when the heat exchanger operates at full capacity.

Function is switched on/off in the **SERVICE** › **DAMPERS** window **RECIRCULATION BY SUPPLY**. It is necessary to indicate *PID* coefficients in the window **ADJUSTER** › **PID CONTROLLERS ADJUSTING**.

5.34.2. FULL RECIRCULATION FUNCTION

This function is designed to save consumption of heating energy, by recirculating only the premises air. It is used only when fresh air is not necessary. During operation of recirculation damper control and **ECONOMY** and **BUILDING PROTECTION** modes, there is a possibility to switch on a full recirculation function.

During this time the recirculation damper is opened and outdoor air damper is closed, exhausted air fan is shut down and the heater maintains the indicated supply air temperature.

5.34.3. OUTDOOR AND SUPPLY AIR RECIRCULATION DAMPERS

If only recirculation damper of supplied air is activated, then it alone shall perform all recirculation functions. If both (outdoor and supply air) recirculation dampers are activated, then their functionality shall be distributed as follows:

The supply air recirculation dampers shall perform the following:

- › Full recirculation function;
- › Supply air temperature control;
- › Shut down of exhausted air fan, when recirculation takes more than 80 %;
- › CO₂ reduction is performed by both dampers.

The outdoor air recirculation dampers shall perform the following:

- › Heat-exchanger de-icing function;
- › In stand-by mode full recirculation (blocking of outdoor air).

The supply and outdoor air recirculation dampers shall perform the CO₂ reduction function.

If the outdoor air recirculation damper is activated, then it is necessary to assign 0-10VDC output for its control.

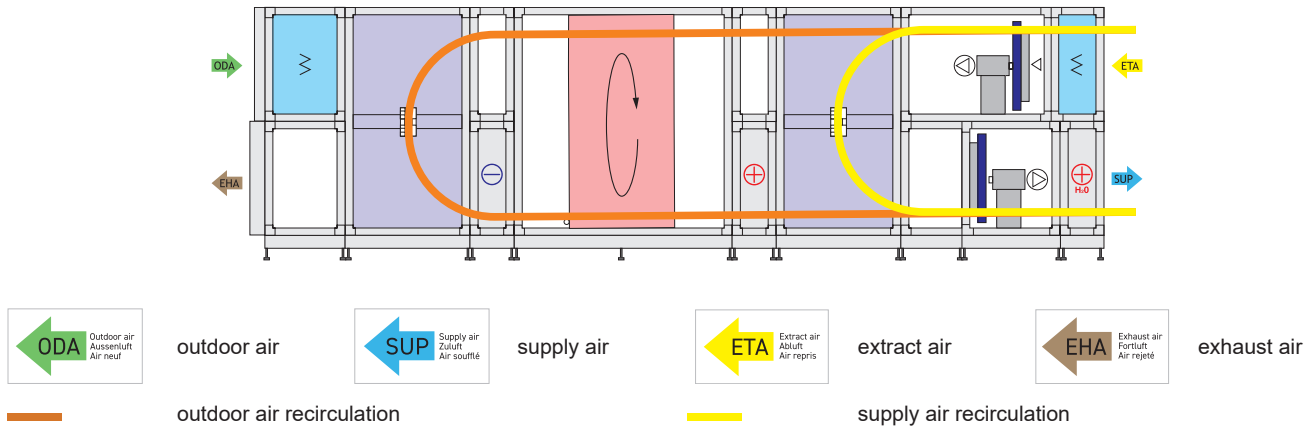

5.34.4. TESTING OF FIRE DAMPERS

Fire dampers may be tested manually or automatically at indicated day intervals. Testing results are stored in event history. If testing fails, a warning is displayed. The user can indicate the damper testing hour (in user settings) as air-flow is then stopped. The necessary position in case of fire is also indicated in the service environment.

The dampers are always monitored by the limit switches for the correct position. If not, the system is stopped and the damper fault is registered. Response times are specified in the service environment as valves may sometimes be tested externally. Closing the dampers stops the flow of air. Dampers are configured in the service environment window **SERVICE › DAMPERS**.

5.35. HEAT EXCHANGER CONTROL

5.35.1. COLD-HEAT RECOVERY

Cold-heat recovery function is designed to control a heat exchanger. Its power is controlled by:

- › Using plate heat exchanger - bypass damper. When it is closed, the heat exchanger is operating at full capacity. Its power is reduced by opening the damper.
- › Rotary heat exchanger power is controlled by changing its rotating speed or interval. When the rotor rotates at full speed, the heat exchanger is used at full capacity. The power is reduced by slowing down the rotating speed or increasing the interval. The heat exchanger can both heat and cool – it depends on air temperature. If it is colder outside than in the premises, the heat exchanger pre-heats the outdoor air by using the room heat. If it is colder in the premises than outside, the heat exchanger cools down the outdoor air temperature by room air. Its power is reduced to the minimum when the target supply air temperature is the same as outdoor one. The higher the difference between the preferred and supply air temperatures, the higher heat exchanger power is used. When it is operating at maximum capacity, it is allowed to activate other heating/cooling components.

For this function suitable heat exchanger type is indicated in the window **SERVICE › HEAT EXCHANGER** and *PID* controller coefficients – in the window **ADJUSTER › PID CONTROLLERS ADJUSTING**.

PID controller output limits are set for rotor or bypass damper, at which their operation starts.

- › If rotor is controlled by 0..10 V signal, at low voltages it does not rotate, the motor heats up, thus the minimum control signal output is limited. If On/Off rotary heat exchanger is used, *PID* percentage for activating the rotor is indicated in the window **SERVICE › HEAT EXCHANGER**.
- › If the bypass damper opens only a few percent, noise can occur, thus the minimum its opening limit is limited, which also applies when coming to the full opening. If the plate heat exchanger with a 3-way bypass damper is used, the opening time of the bypass damper is indicated in the window **SERVICE › HEAT EXCHANGER**.
- › If a plate heat exchanger with segment valves is controlled by an external controller is used, then the type of the bypass damper **REMOTE CONTROLLER** is shown in the window **SERVICE › HEAT EXCHANGER**.
- › If a plate heat exchanger with segment valves connected to a controller is used, then the type of the bypass damper is shown in the window **SERVICE › HEAT EXCHANGER** as either **2 SEGMENTS** or **3 SEGMENTS**. In the case of heat recovery control, segments are closed in sequence, i.e. if heat recovery is not required, then all the segments are closed and the bypass damper is opened.

When the fans are switched on during the heating season, the heat exchanger runs for 10 minutes at full power, until the system stabilizes.

5.35.2. HEAT EXCHANGER FROST PROTECTION

This protection is designed to protect the heat exchanger from the formation of ice inside because ice formations can damage the structure of the heat exchanger. The protection is configured in the service environment, in the window **SERVICE › HEAT EXCHANGER**.

The protection can be activated/deactivated according to the following:

- › Specified outdoor air temperature;
- › Specified exhaust air temperature;
- › Specified exhaust air temperature difference compared to the calculated freezing temperature (this temperature is calculated according to the outdoor air temperature, room air temperature and humidity);
- › According to the pressure switch.

Possible protection measures (to be carried out one by one as specified):

- › Recirculation of outdoor and exhaust air;
- › Opening of the bypass damper or control of the segment valve, or slowing-down of the rotor;
- › Heating of outdoor air using a preheater;
- › Suspension of the supply air flow or reduction of the flow based on the set exhaust air temperature;
- › Shutting-down of the unit according to the low supply air temperature (by default, the limit is 5 °C);
- › Shutting-down of the unit if there are no protection measures activated (shut-down after 5 minutes);
- › Shutting-down of the unit due to failure to reach the safe zone corresponding time interval (two cycles, by default, 60 minutes);
- › Shutting-down of the unit according to the critical outdoor air temperature (to be shut down after 60 seconds).

The protection activation conditions and protection measures can be activate selectively. The protections are active only when the outdoor air temperature drops below the set limit, i.e. the protections will respond to the pressure switch only when the outdoor air temperature drops below the permissible limit. For the anti-frost protection, the time interval after which the system switches from one protection measure to another is also specified (by default, it is 30 minutes). If at least one of the activation conditions is satisfied, the protection becomes active and a message is shown. The initial protection is recirculation, which is followed by the bypass damper or segment valve, then preheater and then, if the power is not sufficient, the supply air flow is suspended. If the protection does not help within the specified time interval (by default, 30 minutes), the system switches to the following one. The protections are switched from one to another in accordance with the sequence.

The recirculation of outdoor and exhaust air is an effective and cost-saving protection but it supplies exhaust air back to the supply air flow. When using the bypass damper or segment valves, the supply air heater must be connected. By slightly opening the damper, the cold air flow through the heat exchanger is reduced but supply air is cooled and must be heated using the supply air heater. This protection slowly opens the bypass damper as long as the activation conditions are satisfied. When suitable conditions are reached, the damper is stopped for 5 minutes and then it is slowly closed. If the outdoor air temperature drops below the permissible level (the heating power is not sufficient), then the damper is forcedly closed according to the supply air temperature.

The bypass valve can also be with segment valves. In this case, the supply air temperature drops less than when using only the bypass damper. At the time of de-icing, segments are closed one by one in sequence, i.e. only one segment can be closed at a time and the bypass damper is opened. If at least one segment is closed, then the bypass damper is opened; if all the segments are opened, then the bypass damper is closed. For the protection with the preheater, the position of the outdoor air sensor in respect of the preheater is specified (upstream/downstream). If the sensor is upstream the preheater, then the unit is not shut down if the required outdoor air temperature is not reached. At the beginning, the outdoor air preheater is activated to the full capacity for a certain period of time, and that it begins maintaining the specified deactivation temperature (outdoor or exhaust air temperature).

If the preheater capacity is not sufficient and the supply air flow reduction is permitted, then the supply air fan is periodically shut down and the heat exchanger is de-iced by heating it with exhaust air. When the fan stops, the supply air damper is closed.

Recirculation, the bypass damper and supply air flow suspension operate in periodic cycles. The minimum de-icing time is 5 minutes, and the minimum time interval between de-icing cycles changes depending on the outdoor air temperature (see the diagram), i.e. the lower the outdoor air temperature is, the shorter the time interval between de-icing cycles. The exhaust air temperature and the pressure switch of the heat exchanger can extend time intervals between de-icing cycles and to extend the de-icing time, i.e. if the minimum time interval after a de-icing cycle has elapsed and the pressure valve has not yet been activated, then its activation is awaited; otherwise, if the required conditions are not achieved within 5 minutes during de-icing (the pressure valve does not reset or the exhaust air temperature does not increase), then de-icing is extended. If the protections according to the pressure switch and/or according to the exhaust air temperature are not activated, then de-icing cycles take place at minimum intervals.

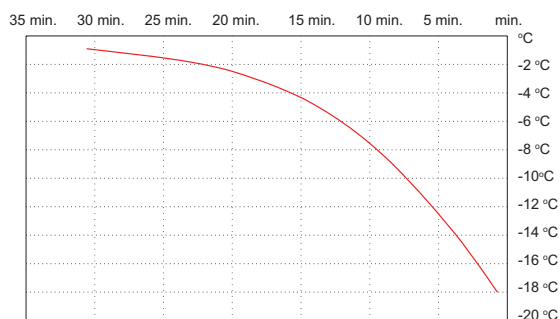

The dependence of the minimum time interval between de-icing cycles (minutes) on the outdoor air temperature.

5.35.3. PROTECTION FROM TOO HIGH CONDENSATE LEVEL

If there's too much condensate, the condensate pump transmit signal to MCB board. The user receives warning immediately. If the signal is active for more than 60 min, airflow will be reduced till minimum. The protection will be disabled automatically after the signal discontinues.

5.35.4. INDICATION OF BYPASS DAMPER FAULT

This function is intended to monitor the operation of the bypass damper (operated by a stepper motor) and only starts functioning after successful calibration.

The closed damper must necessarily push the end position switch, which must disconnect when it opens by more than 25 %. When the damper is not operating correctly, a fault message is displayed.

5.36. HEATERS

5.36.1. SUPPLY AIR HEATER

The heater additionally pre-heats the supply air when the heat exchanger power is insufficient. It is controlled by means of a *PID* controller based on the temperature indicated in the system and based on data of the supply air temperature sensor. One supplied air heater can be connected to this system. It may be either electric or water heater. *PID* controller coefficients are set in the adjuster environment window **ADJUSTER › PID CONTROLLERS ADJUSTING**.

Possible options of supplied air heaters in this system:

- › Supplied air heater is not used;
- › Electric heater is controlled by 0..10VDC signal;
- › Electric heater is controlled by On/Off signal. PWM control interval in seconds is set to control it;
- › Water heater.

Types of heaters are indicated in the service environment window **SERVICE › HEATERS**. Also it is possible to swap connection of the pre-heater and heater protections and control signals.

5.36.2. ELECTRIC HEATER OVERHEAT PROTECTION

The electrical heater can have two protections: automatic and manual. The automatic protection automatically deactivates when the heater has cooled down, and the manual protection should be deactivated by pressing the switch on the heater.

The automatic protection is checked at all times, while the manual protection is checked only when the heater is activated.

When the automatic protection is activated, the heater and its power circuit are disconnected, a message is shown and cooling is ensured by an increased air flow. The automatic protection is eliminated automatically. The fan speed is controlled according to the supply air temperature, i.e. if the supply air temperature drops below the minimum, the fan speed is reduced. When the manual protection is activated, the heater and its power circuit are disconnected, a warning is shown and the indicated action is performed. According to the factory settings, blowing is carried out a the full capacity in order to ensure the maximum cooling of the heater because there is a probability that the manual protection may be blocked and leave it operating. Certainly, if it is activated properly, when blowing at the full capacity in winter, the supply air temperature falls rapidly to the critical level and the system is shut down in any case.

The protection is configured in the window **SERVICE › HEATERS** of the service environment.

5.36.3. COOLING OF ELECTRIC HEATERS

If the used electric heater and the system wants to shut down the fan, the heaters are switched off and they are cooled down by blowing for an indicated time period. A user is notified of heater cooling. Time is indicated in the service environment section **SERVICE › HEATERS › ELECTRICAL HEATERS COOLING**. The fan speed is controlled according to the supply air temperature.

5.36.4. WATER HEATER FROST PROTECTION

The protection is always active, because the heater uncontrolled by this automation can be switched on in the supply air duct. The minimum allowable supply air and return water temperature is indicated. If any of them drops below the indicated temperature or the thermostat is activated, the unit is shut down and warning is displayed. The heating drive opens 100%.

This function also protects the heater against cold air when starting up the system in winter. Prior to switching on the fans the heater is allowed to operate for the indicated time period at 100 %.

Always in winter (even in Stand-by mode) the minimum 20 °C return water temperature is maintained, moreover the circulation pump is always rotating and the damper is not fully closed (stays ajar at least 5 %).

Protection is configured in the service environment section **SERVICE › HEATERS › HYDRONIC HEATERS PROTECTION**.

5.36.5. PROTECTION OF WATER HEATER CIRCULATION PUMPS

Circulation pumps of the water heater and pre-heater must be always on during the entire winter. In summer they are switched on for 30 minutes for preventive check at indicated time intervals.

Circulation pump signals are also monitored. If a failure is reported, the circulation pump is switched off. The fault is canceled manually. You can specify whether to stop ventilation or only to display the message.

Protection is configured in the service environment section **SERVICE › HEATERS › HYDRONIC HEATERS PROTECTION**.

5.36.6. OUTDOOR AIR PRE-HEATER

Outdoor pre-heaters are controlled based on frost protection. The water pre-heater, as the same type heater, is pre-heated before system start-up. In winter the circulation pumps are always rotating, and in summer they are switched on for 5 minutes for preventive check at indicated time intervals.

Possible options of outdoor heaters:

- › Supply air pre-heater is not used;
- › Electric pre-heater is controlled by 0..10 VDC signal;
- › Electric pre-heater is controlled by ON/OFF signal. PWM control interval in seconds is set to control it;
- › Water pre-heater.

Types of pre-heaters are indicated in the service environment window **SERVICE › HEATERS**.

5.36.7. OUTDOOR AIR WATER PRE-HEATER FROST PROTECTION

The minimum allowable return liquid temperature is indicated. If it drops below the indicated temperature, the unit is shut down and warning is displayed. The most common liquid is glycol, therefore the protection must be set according to its parameters. This protection also protects the pre-heater against cold air when starting up the system. If this unit is switched off in winter, it is automatically pre-heated prior to starting up the fans, i.e. it is allowed to operate for the indicated time period at 100 %. Protection is configured in the service environment window **SERVICE › HEATERS**.

5.37. COOLERS

In this system, when the heat exchanger cooling power is not sufficient, a water or freon cooler may be used. They help to reduce the supply air temperature.

Indicates the water cooler water freezing point. Also freon cooler control type (ON/OFF or 0..10 V), the minimum time between ON/OFF, possibility to switch to heating mode is set. In this case the deicing time is set.

Coolers are configured in the window **SERVICE › COOLERS**.

5.37.1. WATER COOLER

The water cooler can be used both as a cooler and a heater; therefore, it is necessary to specify whether the cooler is used only for cooling or for cooling and heating.

The heating mode can be activated as follows:

- › According to the heating season (according to the 3-day outdoor air temperature or the date)
- › According to the return water temperature (limit: 20°C)
- › According to the digital signal (external contact)

In the heating mode, the cooler operates according to the algorithms of the water heater.

5.37.2. FREON COOLER

For the freon cooler, the following is indicated: the control type (**ON/OFF** or **0..10 V**), minimum interval between activation and deactivation, minimum outdoor air temperature, and the possibility to switch into the heating mode. If the possibility to switch to the heating mode is activated, then the de-icing time is indicated.

If the freon cooling control is indicated as **0..10 V** and the heating mode is active, then the automatics respond to the de-icing status of the external controller (transmitted through the Modbus communications line). If de-icing is in progress, then the exhaust air fan is slowed down, the air heater is activated at full capacity. After de-icing, the exhaust air flow is increased and water drops are blown away.

The configuration of coolers in the window **SERVICE › COOLERS**.

5.37.3. THE MINIMAL OUTDOOR AIR TEMPERATURE OF THE FREON COOLER/HEATER

The minimal fresh air temperature, at which the DX cooler/heater can operate, is indicated. If the fresh air temperature drops below the specified limit, then the DX cooler/heater is shut down.

5.37.4. THE FREON COOLER/HEATER AIR FLOW PROTECTION

The minimal supply air flow, at which the DX cooler/heater can operate, is indicated. If the supply air flow drops below the specified limit for more than 60 s, then the DX cooler/heater is shut down and a warning message is shown.

Also, the maximal speed change of the supply air fan (in percentage points per second) is indicated when the DX cooler/heater operates. If the DX cooler/heater operates, then the rapid switching of the supply air fan from one speed to another is restricted.

5.37.5. AUTOMATIC ADJUSTMENT OF DEFROST INTERVALS OF THE FREON COOLER/HEATER

This function is designed to automatically adjust the defrost intervals (using external controller) by monitoring the time of this process. Modbus communicates the dynamic time interval settings from the MCB to the heat pump controller.

This function specifies the required initial interval between defrosting and the defrosting time (e.g. 3 min.). After defrosting, the automatics compares how long this process lasted. If it lasts longer than specified, the time between defrosting is reduced by 5 minutes, and if shorter, then extended by 5 minutes.

Maximum time between defrosting – 360 min.

5.38. DIGITAL INPUT CONFIGURATION

In this system you can set a normal state of every digital input, i.e. indicate whether the contactor is normally open or closed (**NORMALLY OPEN (NO)**, **NORMALLY CLOSED (NC)**). The fire protection contactor must be NC as in case of fire the contactor may break due to burnt cable.

Digital inputs are configured in the service environment window **SERVICE › DIGITAL INPUTS**.

5.39. SENSOR CONFIGURATION

In this system, three 0-10V DC sensors and eight temperature sensors can be used. The following can be connected to two 0-10 VDC inputs:

- › supply air RH sensor;
- › exhaust air CO₂ sensor;
- › exhaust air RH sensor;
- › supply air pressure switch;
- › exhaust air pressure switch;
- › an additional supply air pressure sensor is designed to measure air flow when the exhaust air fan is controlled by the supply air fan flow;
- › an additional exhaust air pressure sensor is designed to measure air flow when the exhaust air fan is controlled by the supply air fan flow.

If pressure switches for more than 3000 Pa are being used, it's necessary to change pressure scale at **SERVICE › SENSORS › AIR PRESSURE FACTOR** to 1.

The pressure sensor of the heat exchanger can be connected to the third 0-10 VDC input.

For each input, the sensor voltage interval (0-10 V, 1-10 V, 0-5 V, 0.6-2.7 V, 0-3.3 V) and the minimum and maximum values are indicated for each input.

Types of temperature sensors:

- › **NONE** – sensor is not connected;
- › **REMOTE** – remote; sensor temperature can be indicated via Modbus;
- › **NTC 10K 3977** – NTC sensor is connected.
- › **NTC SENSOR** with a non-standard beta (2750 – 5000). After changing the beta coefficient, it is necessary to save and restart.

In this system every type of sensors and possible actions in case of failure are indicated.

- › Do nothing – only warning is displayed;
- › Shut down the system – system is stopped, alarm is displayed;
- › Emergency mode – operation is continued, but sensor-dependent functions are switched off, warning is displayed.

Sensors are configured in the service environment window **SERVICE › SENSORS**.

5.39.1. SENSORS ADJUSTING

In this system, the linear adjustment of the sensors is possible, i.e. the indications of each sensor can be adjusted through +/- 100.0 °C, %, Pa, and ppm.

The adjustment of the sensors is performed in the adjuster environment, in the window **ADJUSTER › SENSORS ADJUSTING**.

5.39.2. MODBUS SENSORS

The list of Modbus sensors that can be connected to MCB board via MB-Gateway:

- | | |
|---|---|
| <ul style="list-style-type: none"> › Supply air temperature; › Extract air temperature; › Exhaust air temperature; › Outdoor air temperature; › Water temperature for water heater; › Water temperature for water preheater; › Water temperature for water cooler; › Control board temperature; › Extract air RH; › Supply air RH; › Extract air CO₂; › Supply air CO₂; | <ul style="list-style-type: none"> › Extract air pressure; › Supply air pressure; › Extract air filter air pressure; › Supply air filter air pressure; › Heat exchanger air pressure; › DX cooler/heater coil pressure. › Supply air flow pressure sensor 2; › Exhaust air flow pressure sensor 2. › An additional supply air pressure sensor is designed to measure air flow when the exhaust air fan is controlled by the supply air fan flow. › An additional exhaust air pressure sensor is designed to measure air flow when the exhaust air fan is controlled by the supply air fan flow. |
|---|---|

If pressure switches for more than 3000 Pa are being used, it's necessary to change pressure scale at **SERVICE › SENSORS › AIR PRESSURE FACTOR** to 1.

5.39.3. PRESSURE LIMITS TO EACH MODE

Various activation limits can be set for each airflow (1, 2, 3, 4) by using Modbus pressure switches for filters, heat exchanger or DX cooler/heater coil. The limits can be set manually or automatically, i.e. by activating calibration function.

The overrun limits are also specified for each sensor.

5.40. COMMUNICATIONS LINE CONFIGURATION

MCB controller has two independent communications lines. One of the lines is dedicated to remote control panels, another one – to *BMS* network. Communication protocol – Modbus *RTU*.

Based on manufacturer set parameters

- › Modbus address – 1;
- › Communications Line speed – 19200;
- › Data package structure – E,8,1 (communications line parity: even).

Communications lines are configured in the service environment window **SERVICE › COMMUNICATION**.

5.41. CONFIGURATION OF MODULES

In the section **SERVICE › COMMUNICATION › INTERNAL COMMUNICATION** you can indicate what modules must be connected to the main board. If this is not done, but anyway they are connected, the setting is not shown automatically. If the module is indicated, but not connected, the system is shut down and error warning is displayed.

5.42. COOKING HOOD FAILURE INDICATION

When cooking hood is used which controls the unit by Modbus communication, the failure indication displaying can be switched on/off therein. When the warning is switched off, it is recommended to connect a remote control panel to the system, where failure indications are displayed. Function is switched on/off in the section **SERVICE › MAIN › COOKING HOOD**.

5.43. CONTROLLER BOX TEMPERATURE MAINTAINING

This function helps to control the temperature of controller box by heater or fan. Temperature is maintained by means of integrated (in *EX1* module) sensor. Preferred temperature and control principle is indicated – by heater or fan. Function is set in the section **SERVICE › MAIN › CONTROLLER CABINET**.

5.44. LOG-IN SESSIONS ARE LIMITED BY A TIME INTERVAL

This function terminates a service and adjuster session every 60 minutes. If a service worker or adjuster forget to log out from the service or adjuster environment, then the controller will automatically lock the environments with passwords after 60 minutes.

6. CONNECTION OF BOARD DIAGRAM AND PERIPHERALS

6.1. MCB, EX1 AND EX2 CONTROLLER'S I/O LIST

MCB						
CONNECTION NO.	CONTACT NO.	FUSE NO.	MAX. CURRENT, A	LED NO.	CONTACT NAME	FUNCTIONAL UNIT TITLE
X1	1				MCB FDI TACHO K_1(GND)	Supply fan speed (RPM)
	2				MCB FDI TACHO A_1(+10V)	
	3				MCB FDI TACHO K_2(GND)	Extract fan speed (RPM)
	4				MCB FDI TACHO A_2(+10V)	
X2	1				PE	Rotor speed (RPM)
	2				GND	Too high condensation (NO)
	3				+24VDC	
	4				MCB HOLO	
X3	1				MCB DI1	Supply air electrical heater automatic protection (NC)/ Supply air Hydronic cooler heating/cooling changeover thermostat (NC/NO)/Water heater circulation pump fail
	2				+12VDC	
	3				MCB DI2	Supply air electrical heater manual protection/
	4				+12VDC	Water heater protection (thermostat) (NC)
	5				MCB DI3	Supply air fan protection (NC)
	6				+12VDC	
X4	1				MCB DI4	Fire protection input (NC)
	2				+12VDC	
	3				MCB DI5	By-pass closed input (NC)
	4				+12VDC	
	5				MCB DI6	Rotor alarm (NC)
	6				+12VDC	Heat exchanger pressure relay (NC)
	7				MCB DI7	Extract air fan failure (NC)
	8				+12VDC	
X5	1				MCB AI1 (NTC)	Supply air temperature sensor
	2				GND	
	3				MCB AI2 (NTC)	Fresh air temperature sensor
	4				GND	
	5				MCB AI3 (NTC)	Exhaust air temperature sensor
	6				GND	
	7				MCB AI4 (0-10V)	Heat exchanger pressure transmitter
	8				GND	
X6	1				MCB AI5 (NTC)	Extract air temperature sensor
	2				GND	
	3				MCB AI6 (NTC)	After HXT air temperature sensor
	4				GND	
	5				MCB AI7 (NTC)	Hydraulic heater ret. fluid temperature sensor
	6				GND	
X7	1				+24VDC	Connection with EX2-X47
	2				+3,3VDC	
	3				GND	
	4				I2C_SDA	
	5				I2C_SCL	
X8	1				PE	BMS connection (RS485)
	2				GND	
	3				+24VDC	
	4				GND	
	5				RS485 A (D+)	
	6				RS485 B (D-)	
	7				RS485 B (D-)	
	8				RS485 A (D+)	

MCB						
CONNECTION NO.	CONTACT NO.	FUSE NO.	MAX. CURRENT, A	LED NO.	CONTACT NAME	FUNCTIONAL UNIT TITLE
X9	1				PE	Remote Control connection (RS485)
	2				GND	
	3				+24VDC	
	4				GND	
	5				RS485_B	
	6				RS485_A	
X10	1				MCB PE	Recirculation damper control 3P
	2				MCB GND	
	3			LED11	MCB RECIRC_+ 24VDC_OPEN (DO4)	
	4			LED12	MCB RECIRC_+ 24VDC_CLOSE (DO5)	
X11	1				MCB PE	By-pass damper control 3P
	2				MCB GND	
	3			LED9	MCB BYPASS_+ 24VDC_OPEN (DO2)	
	4			LED10	MCB BYPASS_+ 24VDC_CLOSE (DO3)	
X12	1				PE	24VDC Power supply for water heater actuator
	2				GND	
	3				+24VDC	
X13	1				+24VDC	By-pass step motor control
	2				STEP_B/	
	3				STEP_B	
	4				STEP_A/	
	5				STEP_A	
	6				+24VDC	
X14	1				GND	Supply air fan control output (0-10VDC)
	2				MCB AO1(0-10VDC)	Extract air fan control output (0-10VDC)
	3				GND	
	4				MCB AO2(0-10VDC)	
	5				GND	Supply air heater control output (0-10VDC)
	6				MCB AO3(0-10VDC)	
X15	1				+24VDC	MCB Power supply 24VDC
	2				GND	
	3				PE	
X18						Remote Control connection (RS485)
X19						BMS connection (RS485, configurable via SL1)
		F1	1/1		MCB protection	MCB power supply fuse
		F2	1/1		MCB protection	MCB peripheral power fuse
				LED1		12V peripheral power indication
				LED2		3.3V peripheral power indication
				LED3		MCB status LED
				LED4		Remote Control (RS485) connection transmit indication
				LED5		Remote Control (RS485) connection receive indication
				LED6		BMS (RS422/485) connection receive indication
				LED7		BMS (RS422/485) connection transmit indication
				LED8		Peripheral power control relay indication

SL1 DIP SWITCH

PURPOSE (ON POSITION)

1	120R line termination resistor
2	1kR connection line pull-up resistor
3	1kR connection line pull-down resistor

MCB EX1						
CONNECTION NO.	CONTACT NO.	FUSE NO.	MAX. CURRENT, A	LED NO.	CONTACT NAME	FUNCTIONAL UNIT TITLE
X20	1				+24VDC	24VDC Power supply for water preheater actuator
	2				GND	
	3				PE	
	4				+24VDC	24VDC Power supply for water cooler actuator
	5				GND	
	6				PE	
X21	1				DI1	Outdoor air electrical preheater automatic protection (NC)
	2				+12VDC	DX cooler defrost input/ Water pre-heater circulation pump fail
	3				DI2	Outdoor air electrical preheater manual protection (NC)
	4				+12VDC	
	5				DI3	System mode switch
	6				+12VDC	
	7				DI4	Fans speed switch
	8				+12VDC	
X22	1				DI5	DX cooler protection (NC)
	2				+12VDC	
	3				DI6	Supply air filter pressure switch (NO)
	4				+12VDC	
	5				DI7	Extract air filter pressure switch (NO)
	6				+12VDC	
	7				DI8	Fire place protection relay input (NC)
	8				+12VDC	
X23	1				DI9	Fire damper opened input (NC)
	2				+12VDC	
	3				DI10	Fire damper closed input (NC)
	4				+12VDC	
	5				DI11	Recirculation damper closed input (NC)
	6				+12VDC	
X24	1				GND	Outdoor air preheater control output (0-10VDC)
	2				AO1(0-10VDC)	
	3				GND	DX cooler control output (0-10VDC)
	4				AO2(0-10VDC)	
	5				GND	Hydronic cooler control output (0-10VDC)
	6				AO3(0-10VDC)	
X25	1				PE	Recirculation damper control output (0-10VDC)
	2				GND	
	3				AO4(0-10VDC)	
	4				GND	Rotor control output/
	5				AO5(0-10VDC)	By-pass position control output (0-10VDC)
X26	1				+24VDC	Recirculation damper step motor control
	2				STEP_A	
	3				STEP_A/	
	4				STEP_B	
	5				STEP_B/	
	6				+24VDC	
X27	1				IND_1	Working indication output (24VDC; max 50mA, 1.2W)
	2				+24VDC	
	3				IND_2	Alarm indication output (24VDC; max 50mA, 1.2W)
	4				+24VDC	
X28	1				GND	Supply/Extract air CO2/RH sensor input\
	2				AI1 (0-10V)	Supply/Extract pressure sensor input (0-10VDC)
	3				GND	Supply/Extract air CO2/RH sensor input\
	4				AI2 (0-10V)	Supply/Extract pressure sensor input (0-10VDC)
	5				GND	Reserved input (0-10VDC)
	6				AI3 (0-10V)	

MCB EX1						
CONNECTION NO.	CONTACT NO.	FUSE NO.	MAX. CURRENT, A	LED NO.	CONTACT NAME	FUNCTIONAL UNIT TITLE
X29	1				GND	Hydronic cooler ret. fluid temperature sensor
	2				AI4 (NTC)	
	3				GND	Hydronic preheater ret. fluid temperature sensor
	4				AI5 (NTC)	
X30	1				+24VDC	24VDC Power supply for Air quality sensor I
	2				GND	
	3				PE	
	4				+24VDC	24VDC Power supply for Air quality sensor II
	5				GND	
	6				PE	
XH1	1				GND	Power supply for air quality sensors, max. 20mA
	2				+5VDC	
	3				GND	
	4				+5VDC	
				LED1		EX1 status LED

EX1-S1

RESET BUTTON

U3	SUP_PRESS	Current supply air flow pressure (Pa)
U4	EXT_PRESS	Current extract air flow pressure (Pa)

MCB EX2						
CONNECTION NO.	CONTACT NO.	FUSE NO.	MAX. CURRENT, A	LED NO.	CONTACT NAME	FUNCTIONAL UNIT TITLE
X32	1	F6	2/2	LED11	DO1	Power supply for Fire damper actuator 1, max 100 mA
	2				N(L1)	
	3				PE	
	4	F6	2/2	LED10	DO2	Power supply for Fire damper actuator 2, max 100 mA
	5				N(L1)	
	6				PE	
X33	1	F6	2/2	LED14	DO3	Hydronic cooler circulation pump
	2				N(L1)	
	3				PE	
X34	1	F6	2/2	LED13	DO4	Control cabin heater/fan control output
	2				N(L1)	
	3				PE	
X35	1				PE	Supply/extract air damper control DO5 (Open) DO6 (Close)
	2				N(L1)	
	3	F6	2/2	LED7	DO5	
	4				DO6	
	5				DO5	
	6	F6	2/2	LED8	DO6	
	7				N(L1)	
	8				PE	
X36	1				PE	Rotor motor control/
	2				N(L1)	Defrost indication (to EMRex)
	3	F7	6.3*/0.5	LED9	DO7	
	4				C - capacitor	
X37	1				N(L1)	
	2				C - capacitor	
X38	1				N(L2)	230VAC Power supply for X32, X33, X34, X35, X36 and X39
	2				N(L1)	
	3				PE	
X39	1				PE	Supply air heater power line/circulation pump
	2				N(L1)	
	3	F4	10/10	LED5	DO8	
X40	1			LED12	DO9 NO	DX cooler reverse (NO-cooling; NC-heating)
	2				DO9 NO	

MCB EX2						
CONNECTION NO.	CONTACT NO.	FUSE NO.	MAX. CURRENT, A	LED NO.	CONTACT NAME	FUNCTIONAL UNIT TITLE
X41	1	F5	10/10	LED6	DO10 NO	DX cooler power line
	2				DO10 NO	
X42	1	F3	10/10	LED4	DO11	Outdoor air preheater power line/circulation pump
	2				N(L1)	
X43	1				PE	230VAC Power supply for X42
	2				L (L2)	
	3				N (L1)	
X44	1	F2	4/4	LED3	DO12	Extract fans power line (IV vent. Max 3,5A)
	2				N(L1)	
	3				PE	
X45	1	F1	4/4	LED2	DO13	Supply fans power line (PV vent. Max 3,5A)
	2				N(L1)	
	3				PE	
X46	1				N(L2)	230VAC Power supply for X44 and X45
	2				N(L1)	
	3				PE	
X47	1				+24VDC	Connection with MCB-X7
	2				+3,3VDC	
	3				GND	
	4				I2C_SDA	
	5				I2C_SCL	
				LED1		EX2 status LED

6.2. CONNECTION OF MCB MAIN BOARD

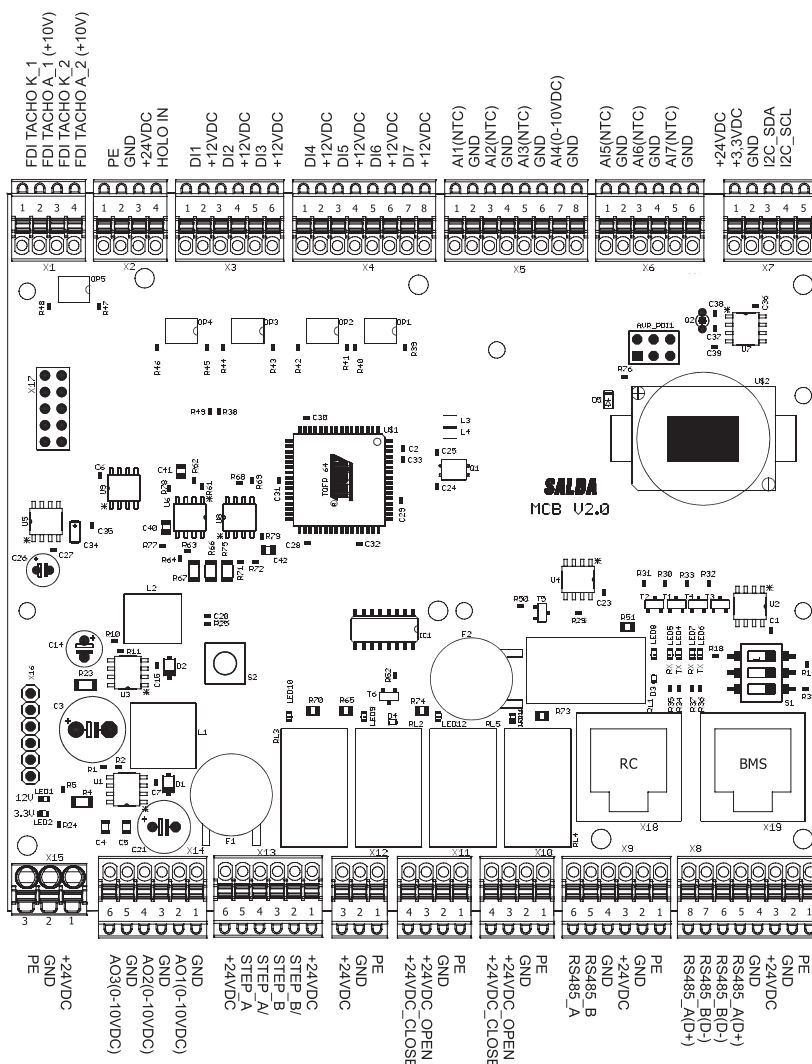

RC - Remote controller

6.2.1. CONNECTION OF FDI_TACHO INPUTS (MCB)

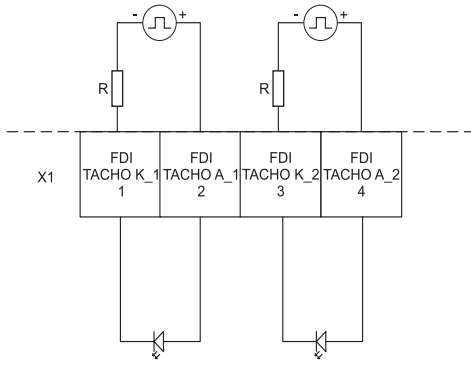

$U_i = 1,5 \text{ V}; I_{i,min.} = 1 \text{ mA}; I_{i,max.} = 50 \text{ mA}$

NOTE: the indicated U_i and I_i parameters shall not be exceeded.

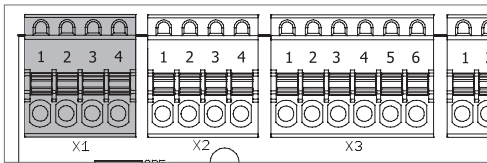

6.2.2. CONNECTION OF HOLO_IN (MCB)

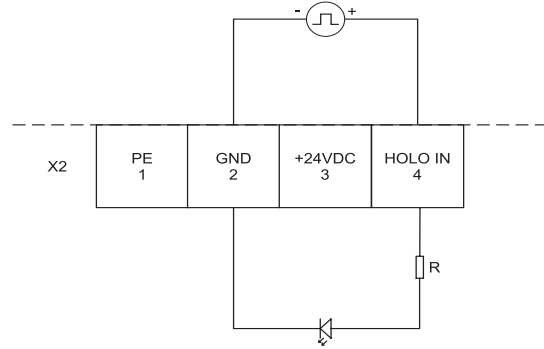

$R = 1 \text{ k}\Omega; U_i = 1,5 \text{ V}; I_{i,min.} = 1 \text{ mA}; I_{i,max.} = 50 \text{ mA}$

NOTE: the indicated parameters shall not be exceeded.

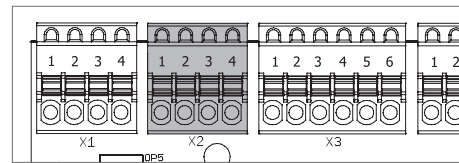

6.2.3. CONNECTION OF DIGITAL INPUTS (DI) (MCB)

Normally closed (NC) or normally open (NO) contact - depends on configuration

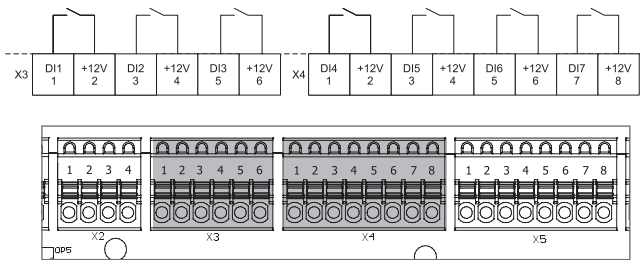

6.2.4. CONNECTION OF TEMPERATURE-ANALOGUE INPUTS (AI NTC) (MCB)

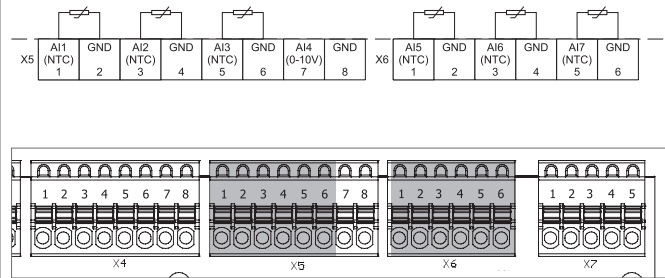

6.2.5. CONNECTION OF ANALOGUE 0-10V (AI 0-10 V) INPUT (MCB)

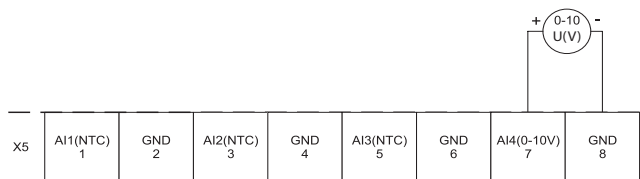

Analog or PWM (max. 30 kHz)

$R_m = \text{min. } 8 \text{ k}\Omega; U(V) - \text{Voltage}$

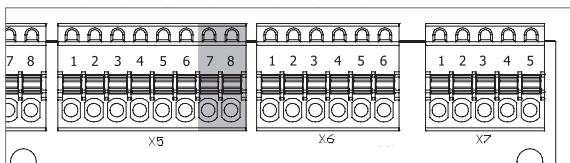

6.2.6. CONNECTION AND CONFIGURATION OF RS422/485 COMMUNICATIONS (MCB)

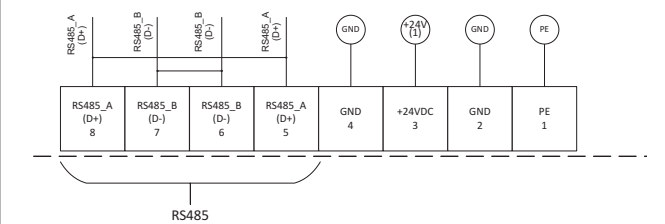

RS485 configuration with switch S1
1 – connection of 120 Ω line load resistor; 2 – 1 kΩ line pull-up resistor; 3 – 1 kΩ line pull-down resistor.

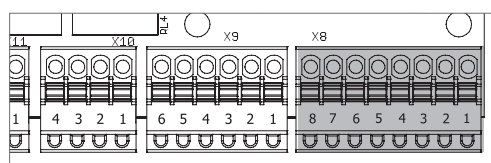

6.2.7. CONNECTION OF RS485 COMMUNICATIONS (MCB)

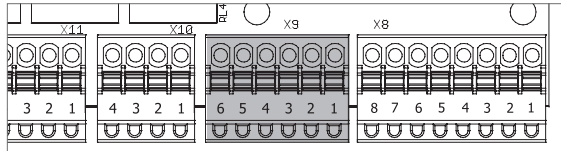
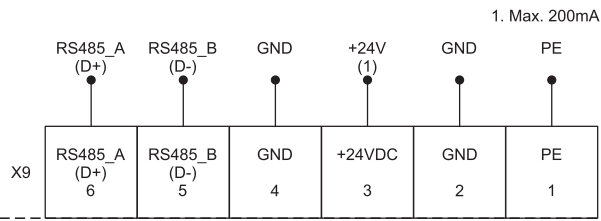

6.2.8. CONNECTION OF RECIRCULATION DAMPER (RECIRCULATION ACTUATOR) (MCB)

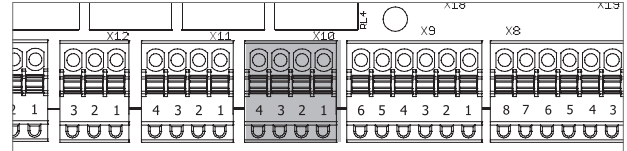
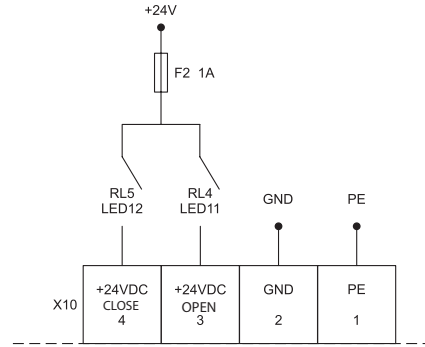

6.2.9. CONNECTION OF BYPASS DAMPER (BYPASS ACTUATOR) (MCB)

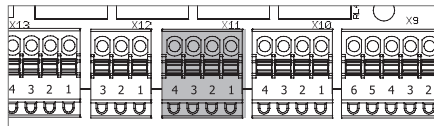
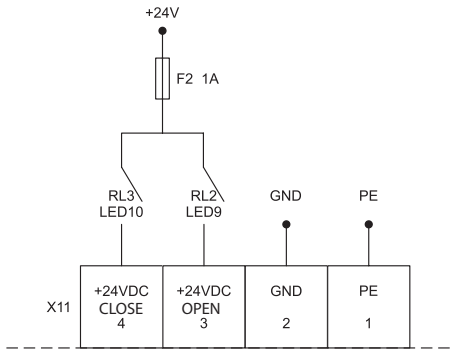

6.2.10. CONNECTION OF WATER HEATER VALVE (WATER HEATER ACTUATOR) (MCB)

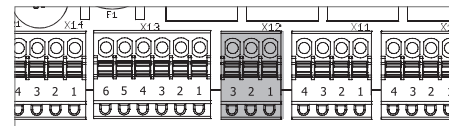
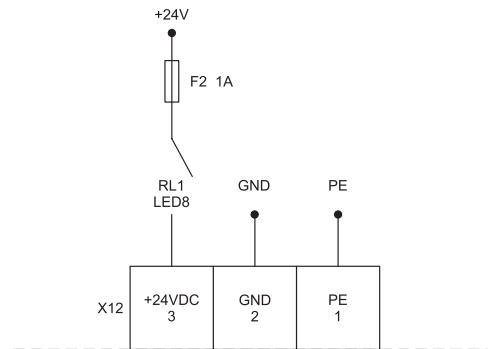

6.2.11. CONNECTION OF BYPASS STEPPER DAMPER (BYPASS STEPPER MOTOR) (MCB)

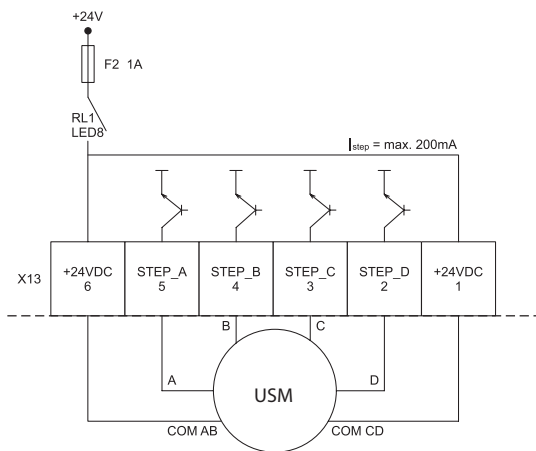

USM - Unipolar step motor

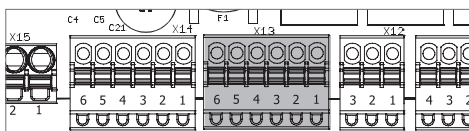

6.2.12. CONNECTION OF ANALOGUE OUTPUTS (AO 0-10 V) (MCB)

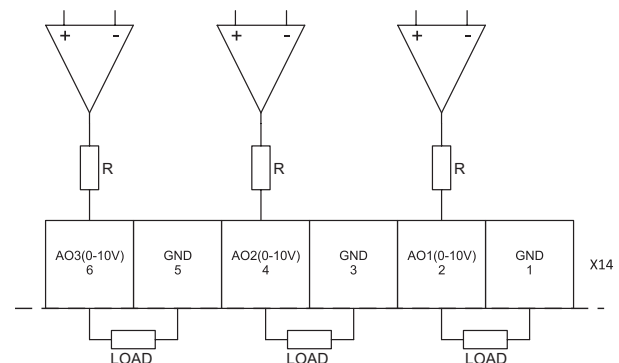

MCB V2.0 PWM 0-10V, 1kHz; MCB V2.0 Analog voltage 0-10V; R=510 Ω

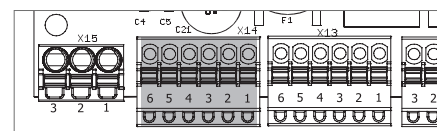

6.2.13. CONNECTION OF POWER SUPPLY SOURCE (MCB)

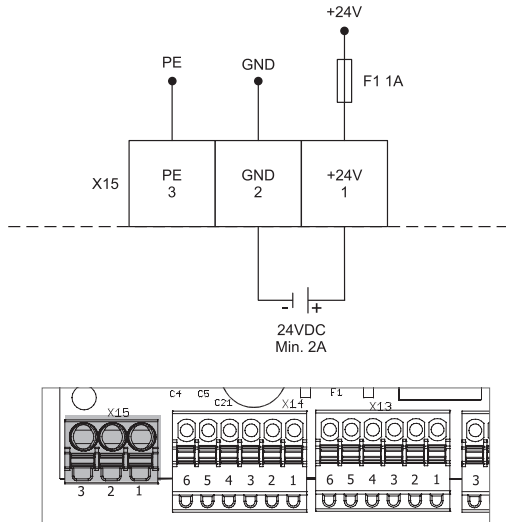

6.3. CONNECTION OF MCB EX1 BOARD

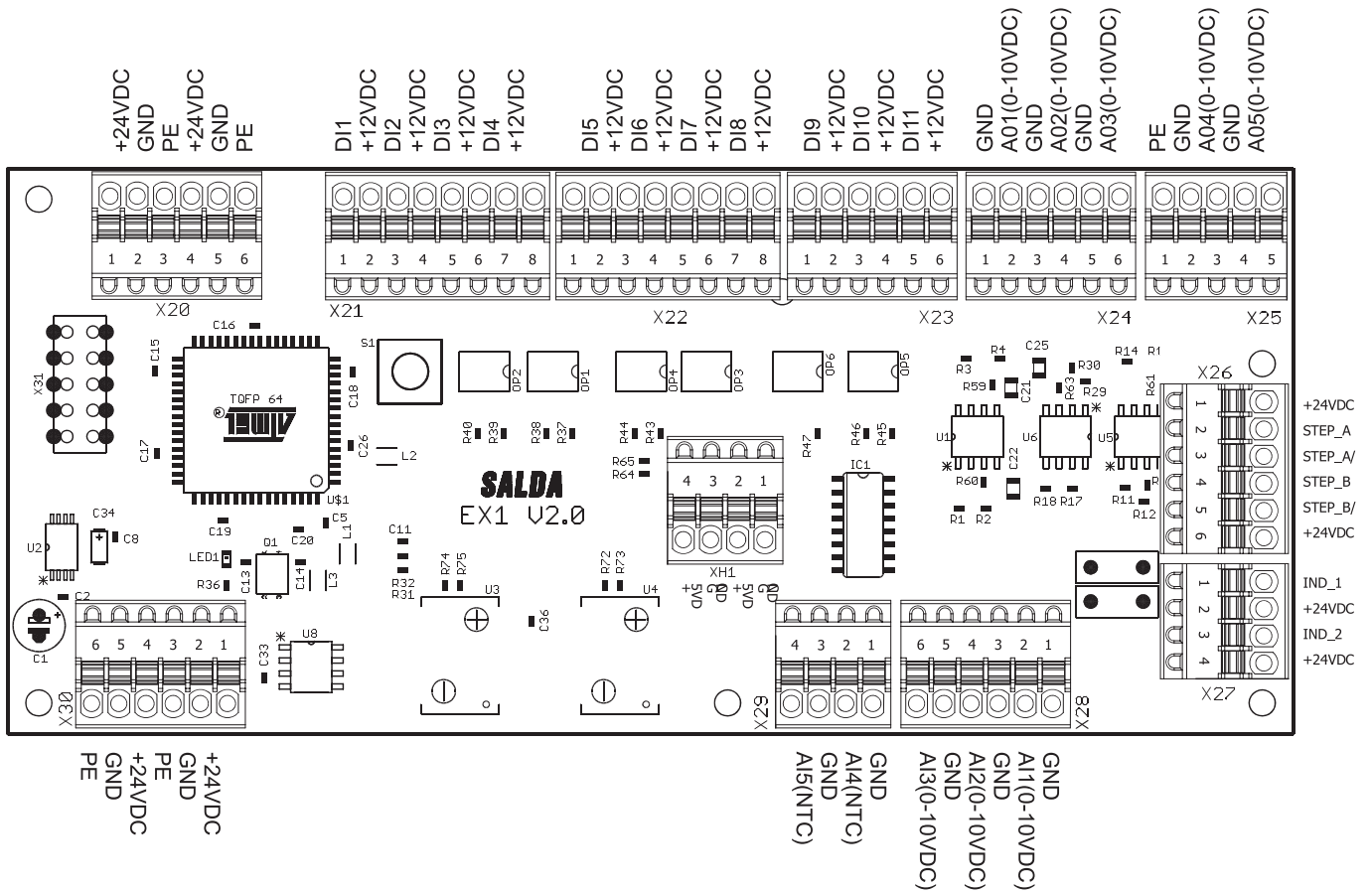

6.3.1. POWER SUPPLY TO WATER PRE-HEATER AND COOLER DAMPER (EX1)

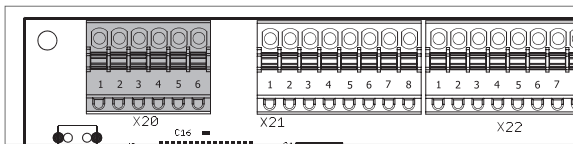
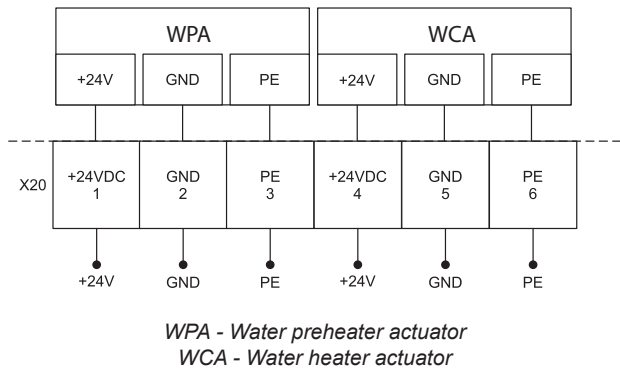

6.3.2. DIGITAL INPUTS (DI) (EX1)

Normally closed (NC) and normally open (NO) contact

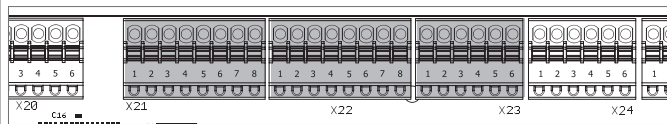
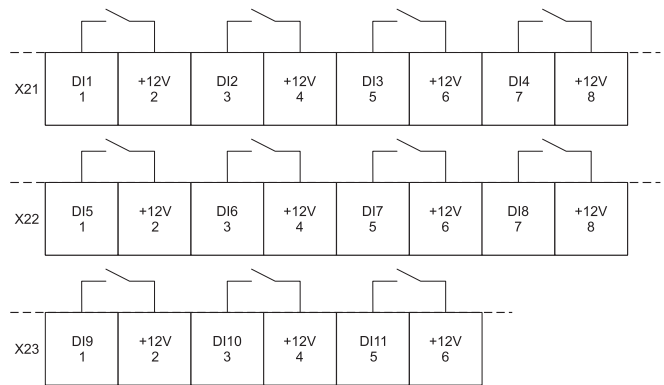

6.3.3. ANALOGUE 0-10V OUTPUTS (AO (0-10 V)) (EX1)

EX1 V2.0 PWM 0-10V, 1kHz; EX1 V2.0 Analog voltage 0-10V;
 $R = 510 \Omega$; Load $\gg R$

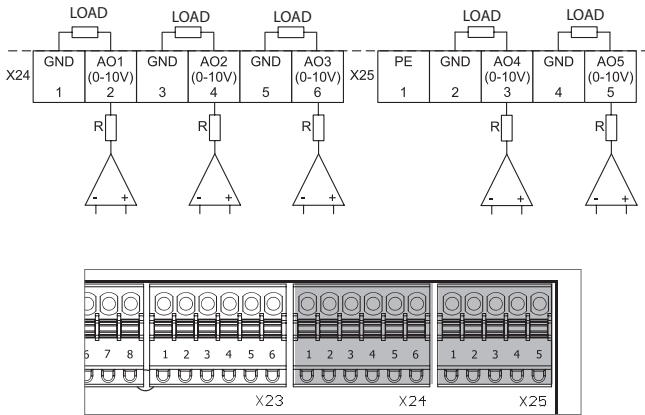

6.3.4. CONNECTION OF STEPPER RECIRCULATION ACTUATOR (EX1)

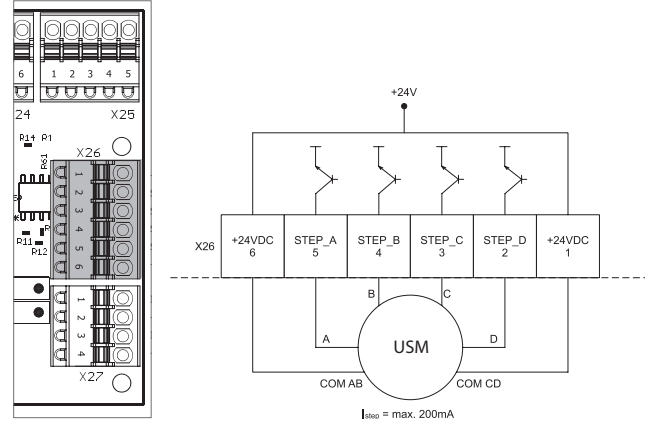

USM - Unipolar step motor

6.3.5. CONNECTION OF INDICATION OUTPUTS (WORKING INDICATION, ALARM INDICATION) (EX1)

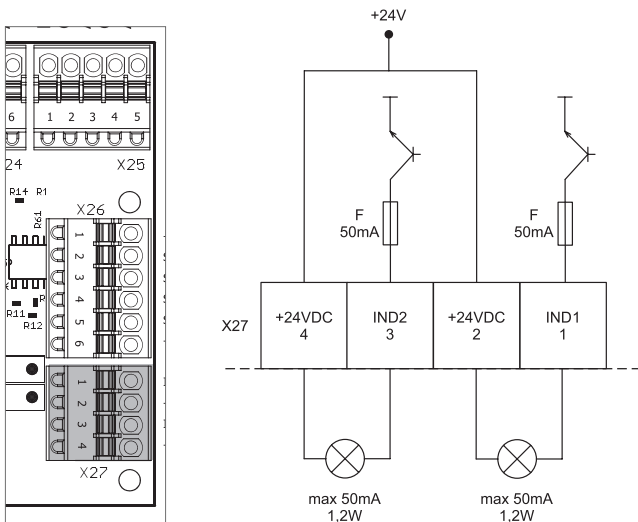

6.3.6. POWER SUPPLY CONNECTION TO AIR QUALITY SENSOR (5VDC) (EX1)

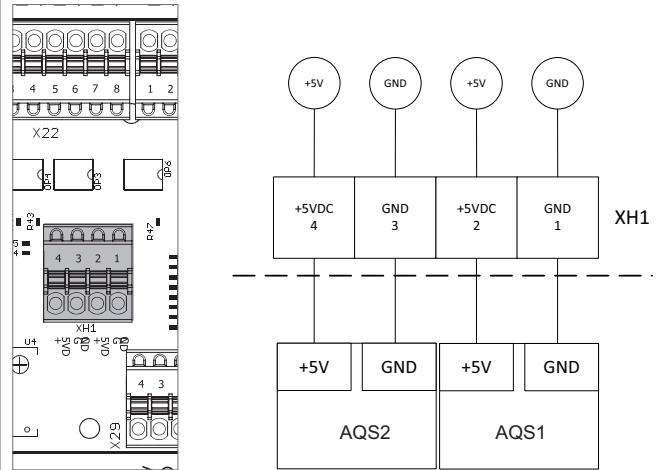

AQS - air quality sensor

6.3.7. CONNECTION OF ANALOGUE 0-10V INPUTS (AI (0-10 V)) (EX1)

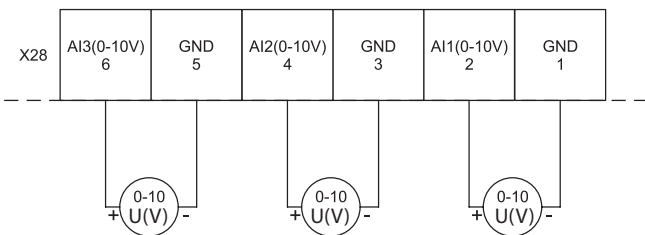

Analog or PWM (max. 30kHz); $R_m = \text{min. } 8 \text{ k}\Omega$; U(V) - voltage

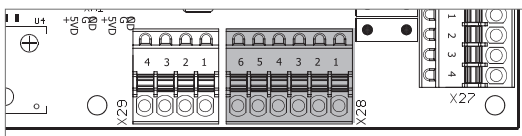

6.3.8. CONNECTION OF ANALOGUE NTC INPUTS (AI (NTC)) (EX1)

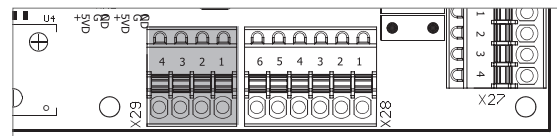
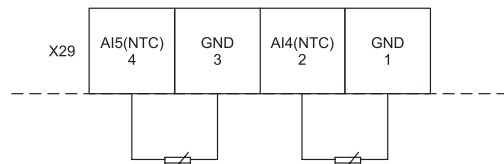

6.3.9. POWER SUPPLY CONNECTION TO AIR QUALITY SENSORS (24VCD) (EX1)

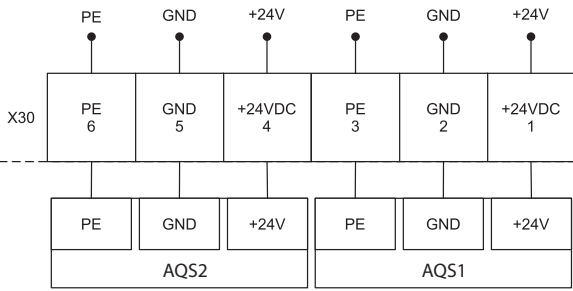

AQS2 - Air quality sensor 2; AQS1 - Air quality sensor 1

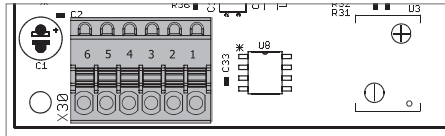

6.4. CONNECTION OF MCB EX2 BOARD

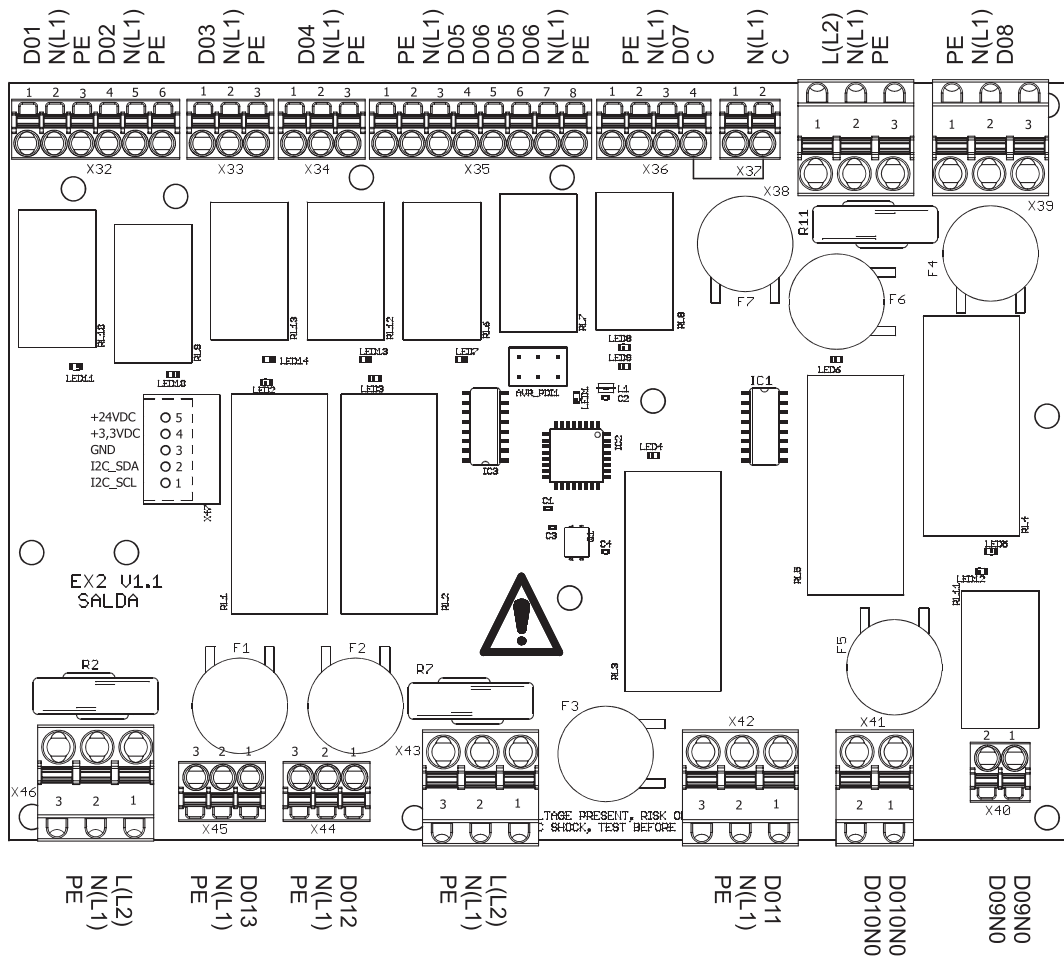

6.4.1. CONNECTION OF FIRE DAMPERS (EX2)

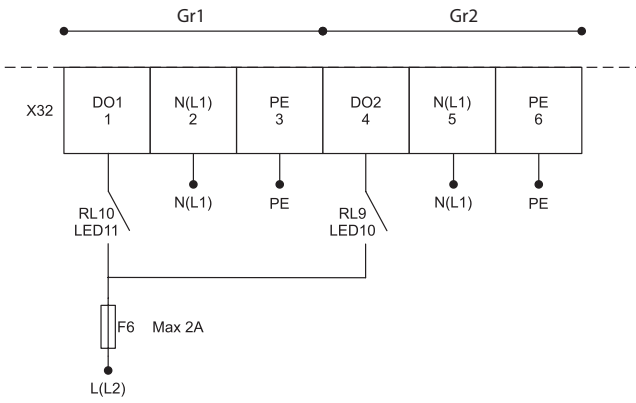

Max 100mA/channel; Gr1 - actuator 1; Gr2 - actuator 2

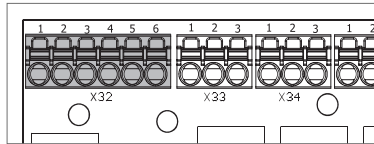

6.4.2. CONNECTION OF WATER COOLER CIRCULATION PUMP (EX2)

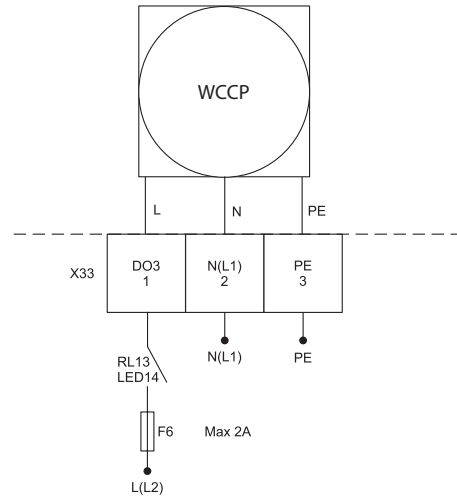

WCCP - water cooler circulation pump

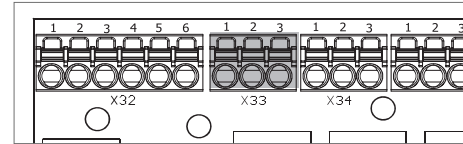

6.4.3. CONNECTION OF CONTROL PANEL HEATER/FAN (EX2)

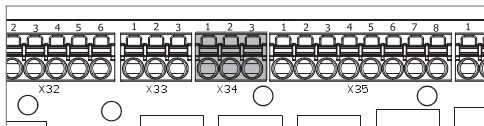
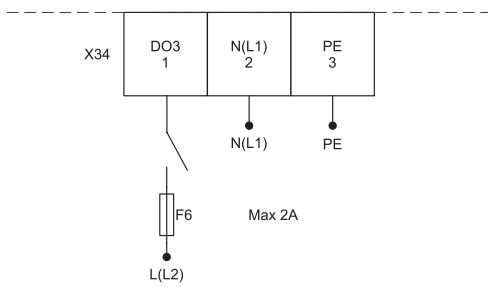

6.4.4. CONNECTION OF AIR DAMPERS (EX2)

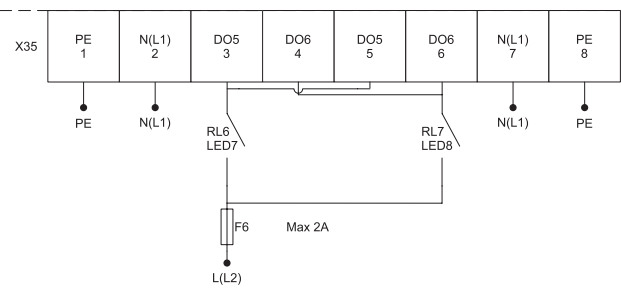

DO5 (OPEN); DO6 (CLOSE)

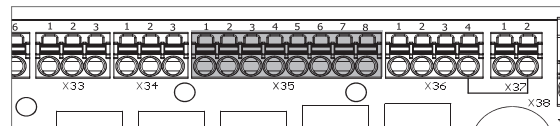

6.4.5. CONNECTION OF ROTOR MOTOR (EX2)

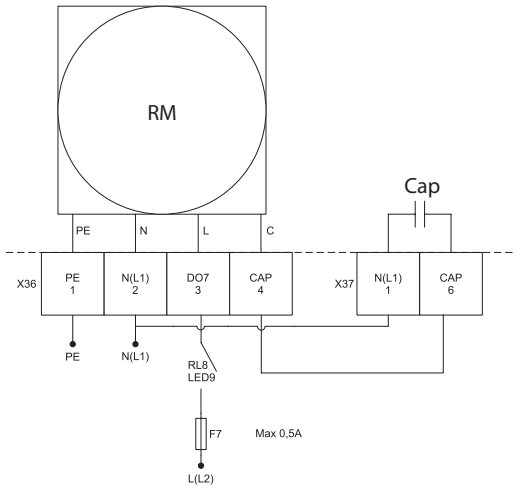

RM - rotor motor; Cap - capacitor

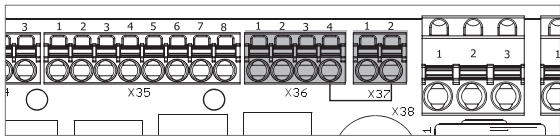

6.4.6. POWER SUPPLY CONNECTION TO TERMINALS X32-X36 AND X39 (EX2)

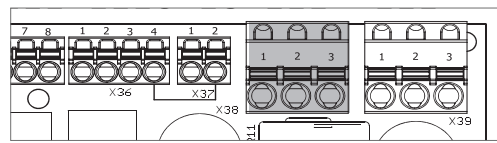
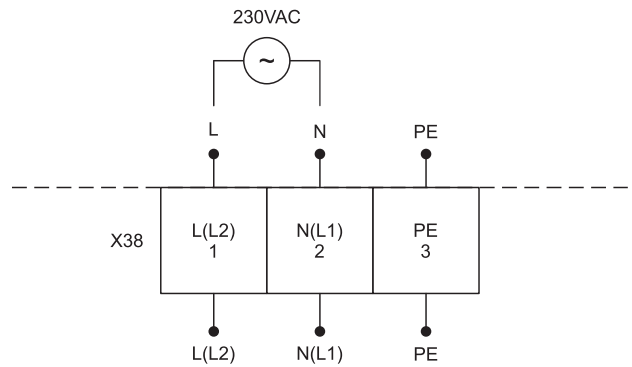

6.4.7. POWER SUPPLY/CONTROL CONNECTION TO ELECTRIC/WATER HEATER OR CONNECTION OF CIRCULATION PUMP (EX2)

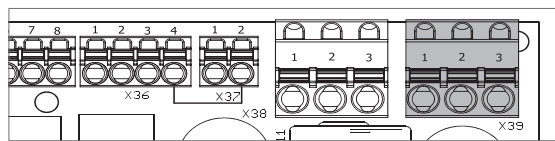
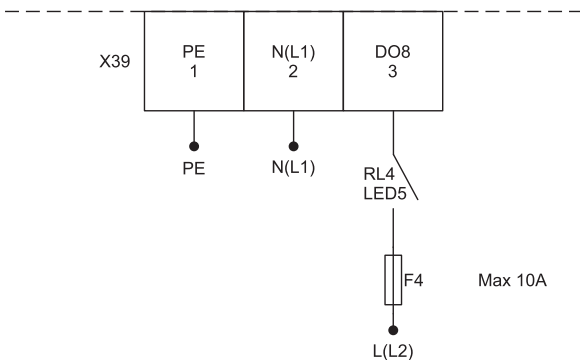

6.4.8. POWER SUPPLY CONNECTION TO FREON COOLER (EX2)

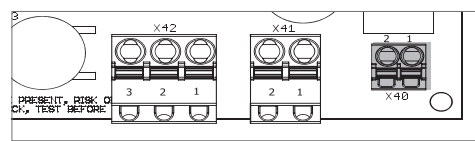
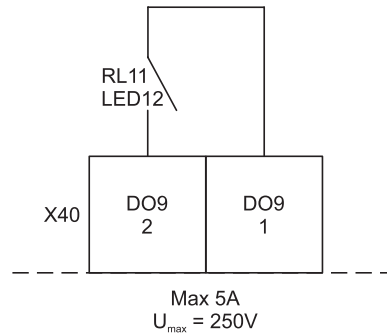

6.4.9. CONNECTION OF REVERSE CONTROL TO FREON COOLER (EX2)

RL5 open - cooling; RL5 close - heating

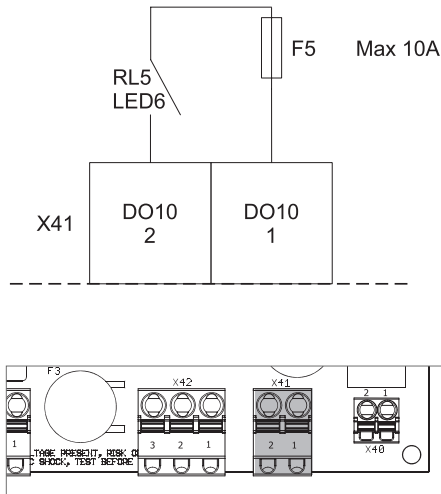

6.4.10. POWER SUPPLY CONNECTION TO PRE-HEATER/CONNECTION OF CIRCULATION PUMP (EX2)

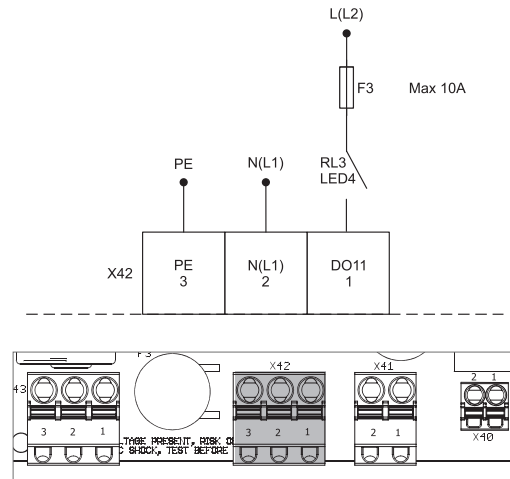

6.4.11. POWER SUPPLY CONNECTION TO TERMINAL X42 (EX2)

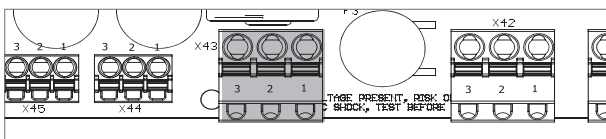
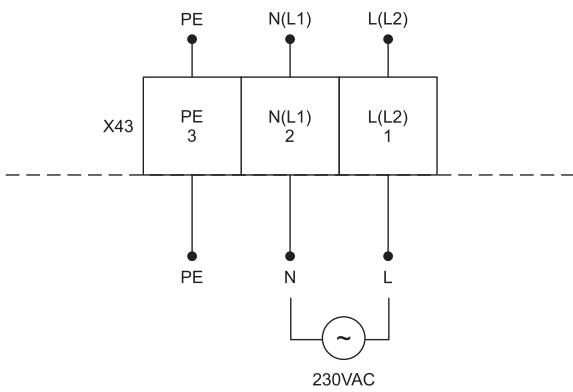

6.4.12. POWER SUPPLY CONNECTION TO SUPPLIED/EXHAUSTED AIR FANS (EX2)

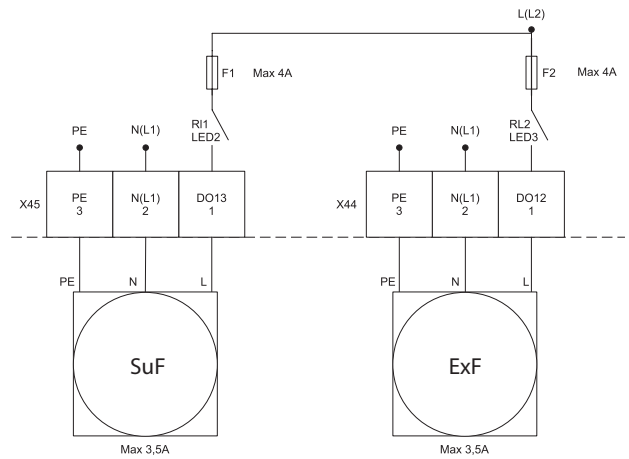

SuF - supply fan; ExF - extract fan

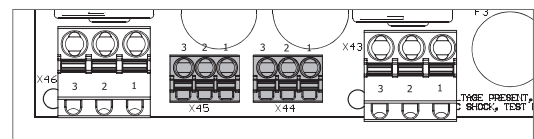

6.4.13. POWER SUPPLY CONNECTION TO TERMINALS X44 AND X45 (EX2)

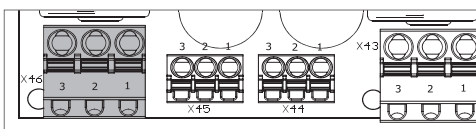
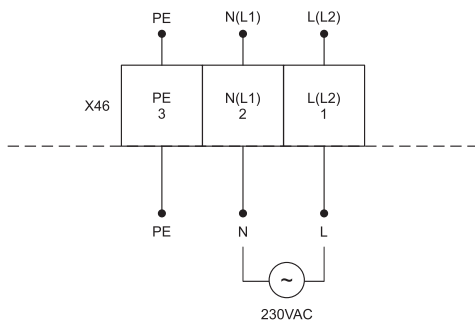

6.5. CONDUCTORS MAXIMUM CROSS-SECTIONS

BOARD	TERMINAL	MAXIMUM CONDUCTOR CROSS-SECTION, MM ² *	STRIP LENGTH
MCB	X1-X14	0.5	8 mm
	X15	1.5	9-10 mm
EX1	X20-X30	0.5	8 mm
EX2	X32-X37, X40, X44, X45	1.5	9-10 mm
	X38, X39, X41-X43, X46	2.5	10 mm

* It depends on wire insulation thickness.

MANUALS IN OTHER LANGUAGES

DK



<https://select.salda.lt/file/mcb-dk>

FR



<https://select.salda.lt/file/mcb-fr>

IT



<https://select.salda.lt/file/mcb-it>

LT



<https://select.salda.lt/file/mcb-lt>

NL



<https://select.salda.lt/file/mcb-nl>

NO



<https://select.salda.lt/file/mcb-no>

PL



<https://select.salda.lt/file/mcb-pl>

SE



<https://select.salda.lt/file/mcb-se>

SK



<https://select.salda.lt/file/mcb-sk>

UA



<https://select.salda.lt/file/mcb-ua>



MAN000476

