

# AMBERAIR COMPACT RIRS 1200-5500 V EKO 3.0 RHX

EN MOUNTING AND INSTALLATION INSTRUCTION



## 1. CONTENT

<b>2. SYMBOLS AND MARKING</b>	<b>3</b>
<b>3. SAFETY INSTRUCTIONS AND PRECAUTIONS</b>	<b>5</b>
<b>4. INFORMATION ABOUT THE PRODUCT</b>	<b>6</b>
4.1. DESCRIPTION	6
4.2. DIMENSIONS AND WEIGHT	6
4.3. TECHNICAL DATA	9
4.4. OPERATING CONDITIONS	10
4.5. STANDARD PACKAGE OF COMPONENTS	10
4.6. DESCRIPTION OF COMPONENTS	10
<b>5. INSTALLATION</b>	<b>11</b>
5.1. RECEPTION OF GOODS	11
5.2. TRANSPORTATION AND STORAGE	11
5.3. UNPACKING	12
5.4. PIPING AND INSTRUMENTATION DIAGRAM	13
5.5. MOUNTING	14
5.5.1. UNIT PLACING AND MOUNTING POSITIONING REQUIREMENTS	14
5.5.2. FLOOR MOUNTING	14
5.6. CONNECTION OF THE AIR DUCT	14
5.7. CONNECTION OF THE UNIT TO ELECTRIC NETWORK	15
5.8. START-UP RECOMMENDATIONS	15
5.8.1. SYSTEM PROTECTION	15
5.8.2. PRE-STARTUP RECOMMENDATIONS OF THE UNIT (IN THE PRESENCE OF THE END-USER)	15
<b>6. MAINTENANCE</b>	<b>16</b>
6.1. SAFETY INSTRUCTION	16
6.2. GENERAL RECOMMENDATIONS FOR VENTILATION SYSTEM MAINTENANCE	16
6.3. COVER OPENING	16
6.4. FILTERS MAINTENANCE	17
6.5. ROTOR MAINTENANCE	17
6.6. FANS MAINTENANCE	17
6.7. HEATER MAINTENANCE	18
6.8. CONTROL BOARD MAINTENANCE	18
<b>7. CONTROL</b>	<b>19</b>
7.1. DEVICE CONTROL	19
7.2. DEVICE FUNCTIONS	19
<b>8. CONNECTION OF ACCESSORIES</b>	<b>20</b>
8.1. FIRE PROTECTION SIGNAL INPUT (FIRE PROTECTION INPUT (NC))	20
8.2. EXTERNAL CO <sub>2</sub> /PRESSURE SENSORS	20
8.3. ROOM CO <sub>2</sub> TRANSMITTER INSTALLATION RECOMMENDATION	20
8.4. CO <sub>2</sub> CONCENTRATION ACCORDING TO PETTENKOFER LIMIT	21
8.5. CONNECTION OF SUPPLY AND EXTRACT AIR DAMPERS	21
8.6. CONNECTION OF REMOTE CONTROL PANEL OR MODBUS	22
8.7. WATER HEATER CIRCULATION PUMP AND VALVE ACTUATOR	22
8.8. RECOMMENDED SCHEME FOR CONNECTION OF INTERNAL AND EXTERNAL COMPONENTS	23
<b>9. POSSIBLE FAULTS AND TROUBLESHOOTING</b>	<b>33</b>
<b>10.ECODESIGN DATA TABLE</b>	<b>34</b>
<b>11.DECLARATION OF CONFORMITY</b>	<b>36</b>
<b>12.WARRANTY</b>	<b>37</b>
12.1. LIMITED WARRANTY COUPON	37

## 2. SYMBOLS AND MARKING

 **Warning – pay attention**

 **Additional information**

Apply the auxiliary label on the unit (on an easily accessible location) or on the dashed location of the technical manual in order to keep the important information about the unit.

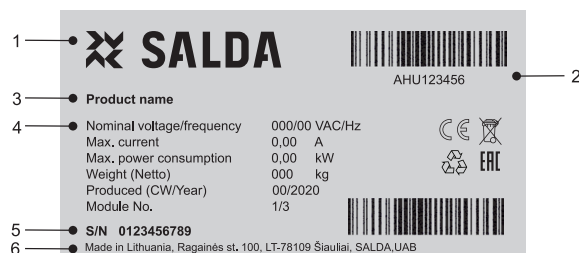

Figure 2.1. Technical label

1 - Logo; 2 - Product code (SKU); 3 - Product name; 4 - Technical data; 5 - Serial number; 6 - Production place.



Figure 2.2. Indication for duct connection.

ODA - outdoor air; SUP - supply air; ETA - extract air; EHA - exhaust air.

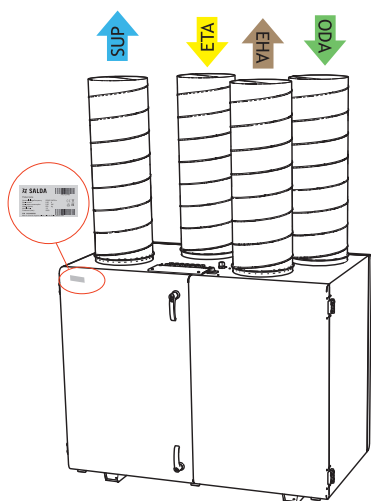

Figure 2.3. Technical label place and air duct indication AmberAir Compact RIRS 1200-1900 V EKO 3.0 (right version)

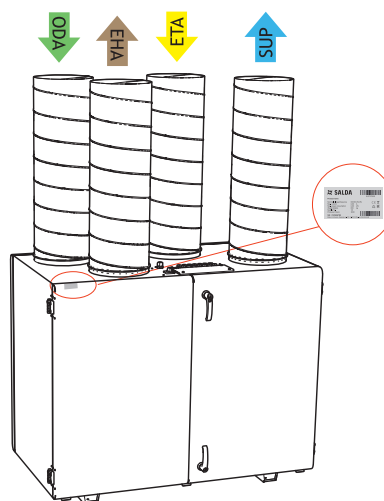

Figure 2.4. Technical label place and air duct indication AmberAir Compact RIRS 1200-1900 V EKO 3.0 (left version)

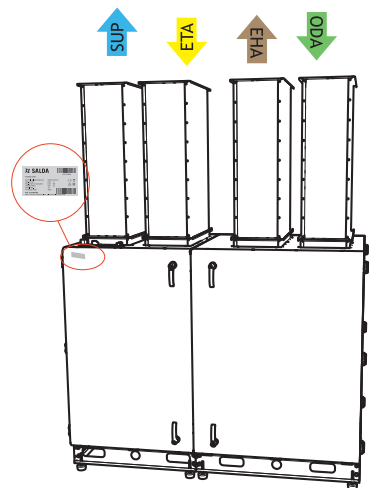

Figure 2.5. Technical label place and air duct indication AmberAir Compact RIRS 2500-3500 V EKO 3.0 (right version)

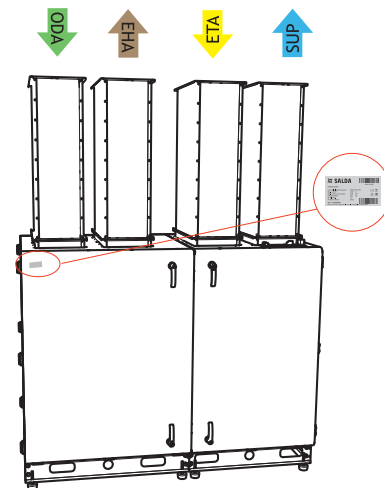

Figure 2.6. Technical label place and air duct indication AmberAir Compact RIRS 2500-3500 V EKO 3.0 (left version)

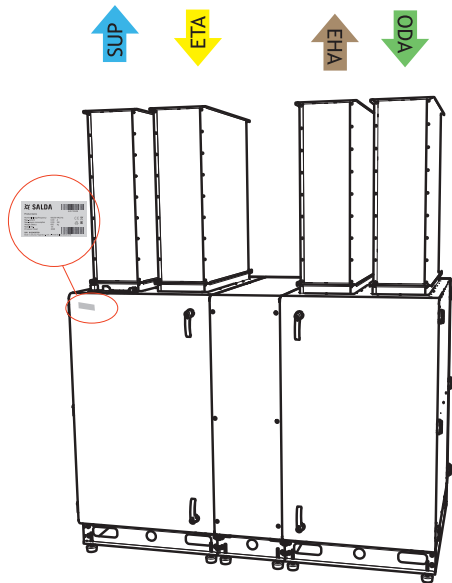

Figure 2.7. Technical label place and air duct indication AmberAir Compact RIRS 5500 V EKO 3.0 (right version)

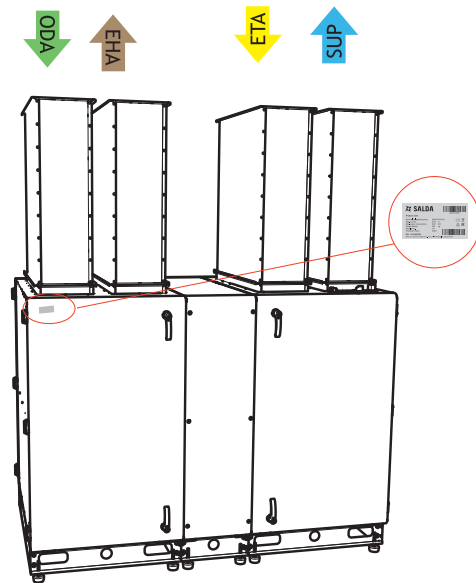

Figure 2.8. Technical label place and air duct indication AmberAir Compact RIRS 5500 V EKO 3.0 (left version)



**NOTE.** Ducts are not the part of the unit.

### 3. SAFETY INSTRUCTIONS AND PRECAUTIONS

Read these instructions very carefully before installing and using this equipment. Installation, connection and maintenance should be carried out by a qualified technician and in accordance with the local regulations and legislation.

The company shall take no responsibility for the injuries or damaged property if the safety requirements are not followed or the device is modified without the permission of the manufacturer.

#### Main safety rules

---

##### **Danger**



- Before carrying out any electrical or maintenance works, make sure that the device is disconnected from the mains and all moving parts of the device have stopped.
  - Make sure that the fans are not accessible through air ducts or branch openings.
  - If any liquids on electric parts or connections that bear voltage are noticed, stop the operation of the device.
  - Do not plug the device into the mains that differ from the one indicated on the label or on the housing.
  - Voltage of the mains should comply with the electro technical parameters indicated on the label.
  - The device should be earthed in accordance with the regulations on the installation of electric devices. Turning on and using unearthed device is not allowed. Follow the requirements specified on the device's labels that indicate danger.
- 

##### **Warnings**



- Connection of electricity and maintenance of the device should be performed by the qualified personnel only and in accordance with the manufacturer's instructions and safety requirements.
  - In order to reduce the risk during installation and maintenance, suitable protective clothing must be worn.
  - Beware of sharp angles while carrying out installation and maintenance works.
  - Do not touch heating elements until they haven't cooled down.
  - Some devices are heavy, you should be very careful while transporting and installing them. Use suitable lifting equipment.
  - When connecting electricity to the mains, a circuit breaker of suitable size must be used.
- 

##### **Warning!**



- If the device is installed in a cold environment, make sure that all connections and tubes are properly isolated. Intake and discharge air ducts should be isolated in all cases.
  - Openings of the ducts should be covered during transportation and installation.
  - Make sure not to damage the heater when connecting the piping of the water heater. For tightening up, use a wrench/spanner.
- 

##### **Before starting up the device**



- make sure, that there are no strange objects inside;
  - manually check fans to make sure they are not stuck or blocked;
  - if rotary heat exchanger is installed in the device, make sure that it is not stuck or blocked;
  - check the earthing;
  - make sure that all components and accessories are connected in accordance with the wiring diagram or provided instructions.
-

## 4. INFORMATION ABOUT THE PRODUCT

### 4.1. DESCRIPTION

AmberAir Compact RIRS V EKO 3.0 is a non-residential air handling unit with a high efficiency (up to 75 %) rotor heat exchanger. The unit supplies ventilation in home and takes the heat from exhaust air. AHU complies with ErP 2018 requirements. The unit is operated by a separate remote control panel or through separate MB-Gateway by PC. Remote control panel and MB-Gateway are optional and not included in standard package.



Not suitable for operation in pools, saunas and other similar premises.

### 4.2. DIMENSIONS AND WEIGHT

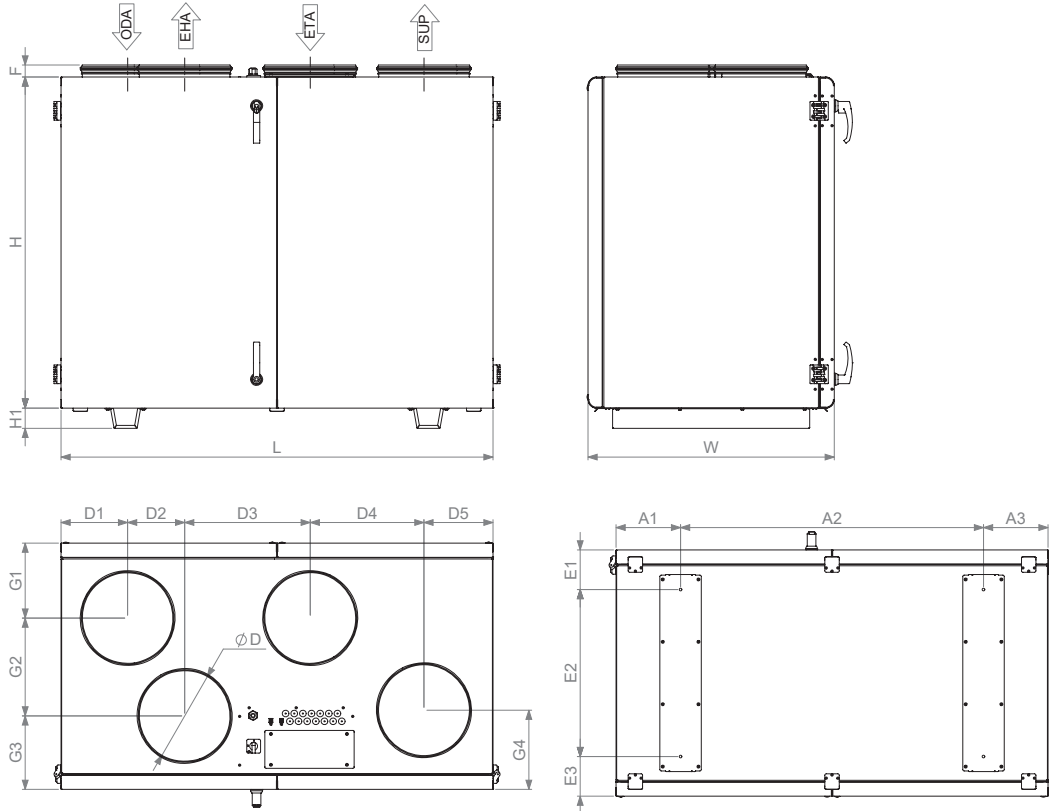

Figure 4.2.1. AmberAir Compact RIRS 1200 -1900 VE/VW EKO 3.0

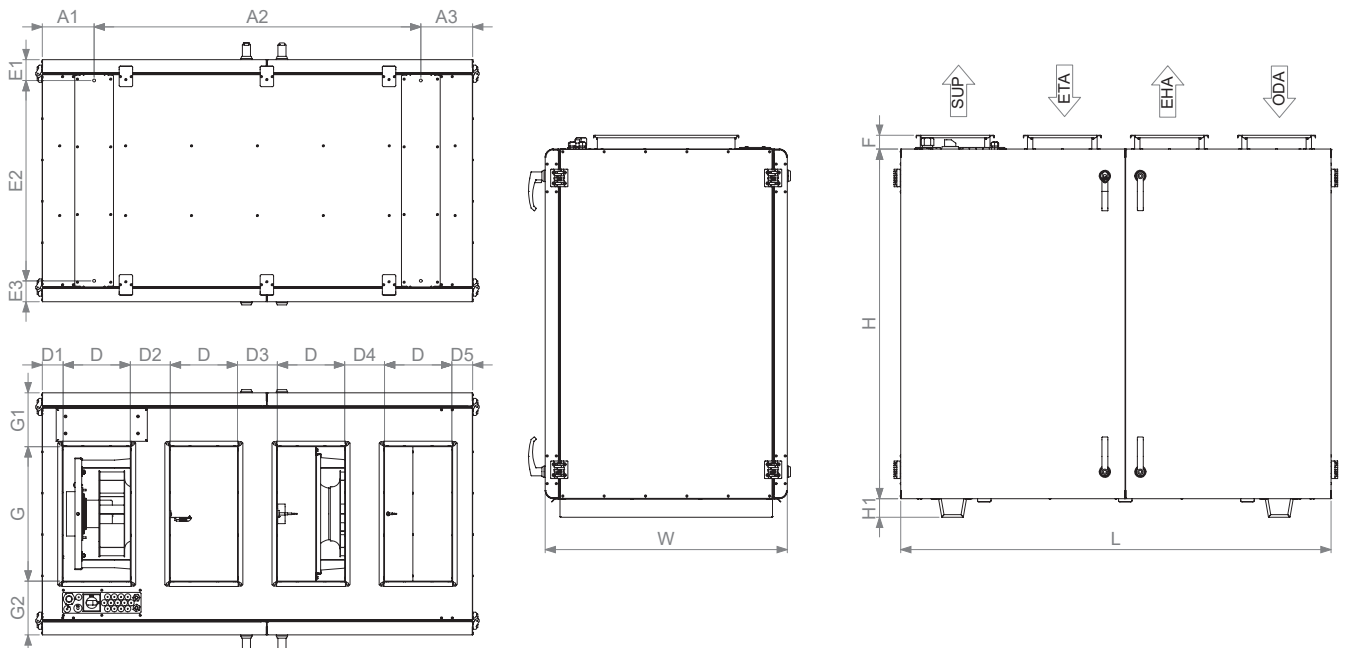

Figure 4.2.2. AmberAir Compact RIRS 2500 VE/VW EKO 3.0

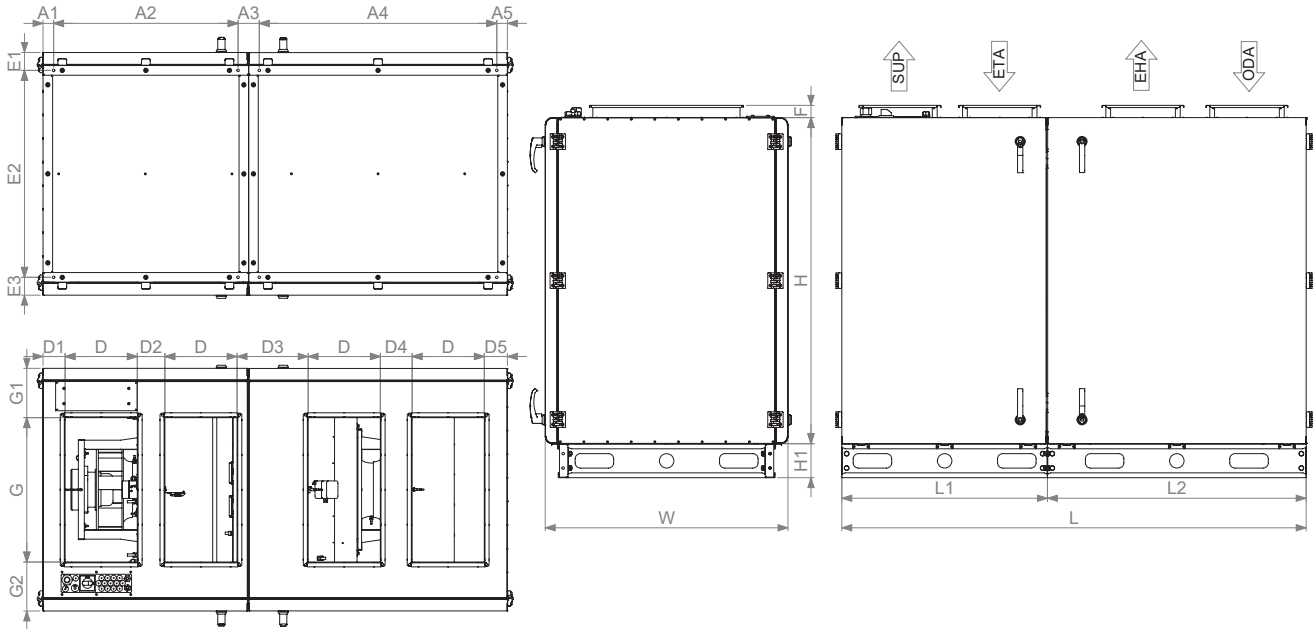

Figure 4.2.3. AmberAir Compact RIRS 3500 VE/VW EKO 3.0

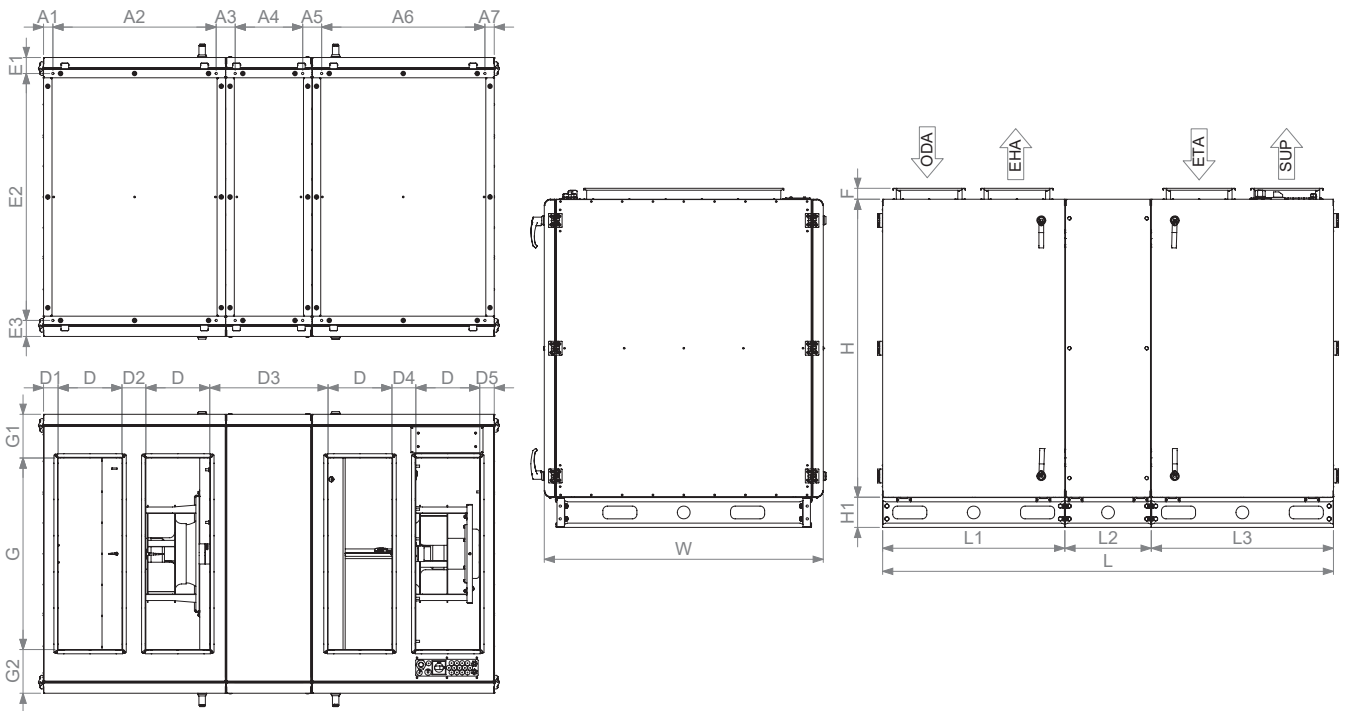

Figure 4.2.4. AmberAir Compact RIRS 5500 VE/VW EKO 3.0

AmberAir Compact RIRS EKO 3.0 RHX		1200 VEL	1200 VER	1200 VWL	1200 VWR	1900 VEL	1900 VER	1900 VWL	1900 VWR	2500 VEL	2500 VER	2500 VWL	2500 VWR	
L	[mm]	1500								1600				
W	[mm]	855								900				
H	[mm]	1150								1300				
ØD / D	[mm]	315								250				
G	[mm]	-								500				
H1	[mm]	70												
F	[mm]	41								51				
A1	[mm]	224								193				
A2	[mm]	1052								1214				
A3	[mm]	224								193				
E1	[mm]	138								78				
E2	[mm]	580								745				
E3	[mm]	138								78				
D1	[mm]	231	240	231	240	231	240	231	240	75				
D2	[mm]	198	395	198	395	198	395	198	395	142				
D3	[mm]	436								140				
D4	[mm]	395	198	395	198	395	198	395	198	142				
D5	[mm]	240	231	240	231	240	231	240	231	75				
G1	[mm]	260								197				
G2	[mm]	340	280	340	280	340	280	340	280	197				
G3	[mm]	255	315	255	315	255	315	255	315	-				
G4	[mm]	275	255	275	275	275	255	275	255	-				
WEIGHT	[kg]	232			229		238		235		329		320	

AmberAir Compact RIRS EKO 3.0 RHX		3500 VEL	3500 VER	3500 VWL	3500 VWR	5500 VEL	5500 VER	5500 VWL	5500 VWR	
L	[mm]	1930				2117				
W	[mm]	1008				1310				
H	[mm]	1355				1400				
ØD / D	[mm]	300								
G	[mm]	600				900				
L1	[mm]	1075	854	1075	854	855				
L2	[mm]	854	1075	854	1075	400				
L3	[mm]	-				855				
H1	[mm]	141								
F	[mm]	51								
A1	[mm]	44								
A2	[mm]	987	767	987	767	767				
A3	[mm]	88				89				
A4	[mm]	767	987	767	987	317				
A5	[mm]	44				89				
A6	[mm]	-				767				
A7	[mm]	-				44				
E1	[mm]	74				75				
E2	[mm]	860				1160				
E3	[mm]	74				75				
D1	[mm]	93	89	93	89	66				
D2	[mm]	126	108	126	108	106				
D3	[mm]	289				550				
D4	[mm]	108	126	108	126	106				
D5	[mm]	89	93	89	93	66				
G1	[mm]	200				202				
G2	[mm]	200				202				
WEIGHT	[kg]	378			370		539		532	



### 4.3. TECHNICAL DATA

AmberAir Compact RIRS EKO 3.0 RHX		1200 VE	1200 VW	1900 VE	1900 VW	2500 VE	2500 VW
<b>EXHAUST AIR FAN</b>							
phase/voltage	[50 Hz/VAC]	1/230	1/230	1/230	1/230	1/230	1/230
power/current	[kW/A]	0,38/2,5	0,38/2,5	0,47/2,04	0,47/2,04	0,715/3,1	0,715/3,1
speed	[min <sup>-1</sup> ]	3370	3370	2530	2530	2800	2800
control input	[VDC]	0-10	0-10	0-10	0-10	0-10	0-10
protection class		IP54	IP54	IP54	IP54	IP54	IP54
<b>SUPPLY AIR FAN</b>							
phase/voltage	[50 Hz/VAC]	1/230	1/230	1/230	1/230	1/230	1/230
power/current	[kW/A]	0,38/2,5	0,38/2,5	0,47/2,04	0,47/2,04	0,715/3,1	0,715/3,1
speed	[min <sup>-1</sup> ]	3370	3370	2530	2530	2800	2800
control input	[VDC]	0-10	0-10	0-10	0-10	0-10	0-10
protection class		IP54	IP54	IP54	IP54	IP54	IP54
Integrated electrical heater	[kW]	4	-	9	-	9	-
Total power/current consumption	[kW/A]	4,76/15	0,76/5	9,94/17,18	0,94/4,08	10,43/19,2	1,43/6,2
Automatic control integrated		PRV	PRV	PRV	PRV	PRV	PRV
Insulation of walls	[mm]	50	50	50	50	50	50
Exhaust air filter (class, dimensions LxWxH)	[mm]	MPL 745x350x46 ePM10-55	MPL 745x350x46 ePM10-55	MPL 745x350x46 ePM10-55	MPL 745x350x46 ePM10-55	MPL 790x400x46 ePM10-55	MPL 790x400x46 ePM10-55
Supply air filter (class, dimensions LxWxH)	[mm]	MPL 745x350x46 ePM1-70	MPL 745x350x46 ePM1-70	MPL 745x350x46 ePM1-70	MPL 745x350x46 ePM1-70	MPL 790x480x46 ePM1-70	MPL 790x480x46 ePM1-70
Device protection class		IP-34	IP-34	IP-34	IP-34	IP-34	IP-34

AmberAir Compact RIRS EKO 3.0 RHX		3500 VE	3500 VW	5500 VE	5500 VW
<b>EXHAUST AIR FAN</b>					
phase/voltage	[50 Hz/VAC]	1/230	1/230	3/400	3/400
power/current	[kW/A]	1,3/5,65	1,3/5,65	1,85/2,9	1,85/2,9
speed	[min <sup>-1</sup> ]	2390	2390	2180	2180
control input	[VDC]	0-10	0-10	0-10	0-10
protection class		IP54	IP54	IP54	IP54
<b>SUPPLY AIR FAN</b>					
phase/voltage	[50 Hz/VAC]	1/230	1/230	3/400	3/400
power/current	[kW/A]	1,3/5,65	1,3/5,65	1,85/2,9	1,85/2,9
speed	[min <sup>-1</sup> ]	2390	2390	2180	2180
control input	[VDC]	0-10	0-10	0-10	0-10
protection class		IP54	IP54	IP54	IP54
Integrated electrical heater	[kW]	12	-	18	-
Total power/current consumption	[kW/A]	14,6/28,64	2,6/11,3	21,7/31,8	3,7/5,8
Automatic control integrated		PRV	PRV	PRV	PRV
Insulation of walls	[mm]	50	50	50	50
Exhaust air filter (class, dimensions LxWxH)	[mm]	MPL 900x455x90 ePM10-55	MPL 900x455x90 ePM10-55	MPL 597x578x90 ePM10-55	MPL 597x578x90 ePM10-55
Supply air filter (class, dimensions LxWxH)	[mm]	MPL 900x528x90 ePM1-70	MPL 900x528x90 ePM1-70	MPL 597x578x90 ePM1-70	MPL 597x578x90 ePM1-70
Device protection class		IP-34	IP-34	IP-34	IP-34

Acoustic data: check the product page on [www.salda.it](http://www.salda.it)



**Not suitable for installation in living rooms: additional noise insulation required.**

#### 4.4. OPERATING CONDITIONS

AmberAir Compact RIRS EKO 3.0 RHX	1200 VE/VW	1900 VE/VW	2500 VE/VW	3500 VE/VW	5500 VE/VW
Minimum outdoor air temperature	-23 °C	-23 °C	-23 °C	-23 °C	-23 °C
Maximum outdoor air temperature	+40 °C	+40 °C	+40 °C	+40 °C	+40 °C
Minimum extracted air temperature	+15 °C	+15 °C	+15 °C	+15 °C	+15 °C
Maximum extracted air temperature	+40 °C	+40 °C	+40 °C	+40 °C	+40 °C
Maximum extracted air relative humidity	60 %	60 %	60 %	60 %	60 %
Minimum ambient air temperature	+5 °C	+5 °C	+5 °C	+5 °C	+5 °C
Maximum ambient air temperature	+40 °C	+40 °C	+40 °C	+40 °C	+40 °C
Installation	indoor/outdoor	indoor/outdoor	indoor/outdoor	indoor/outdoor	indoor/outdoor

#### 4.5. STANDARD PACKAGE OF COMPONENTS

AmberAir Compact RIRS EKO 3.0 RHX	1200 VE/VW	1900 VE/VW	2500 VE/VW	3500 VE/VW	5500 VE/VW
Anti vibration mounts S-00 SV-00	-	-	4	8	12
Handle 265076-00	1	1	3	2	2
Handle with lock 265076-10	1	1	1	2	2

#### 4.6. DESCRIPTION OF COMPONENTS

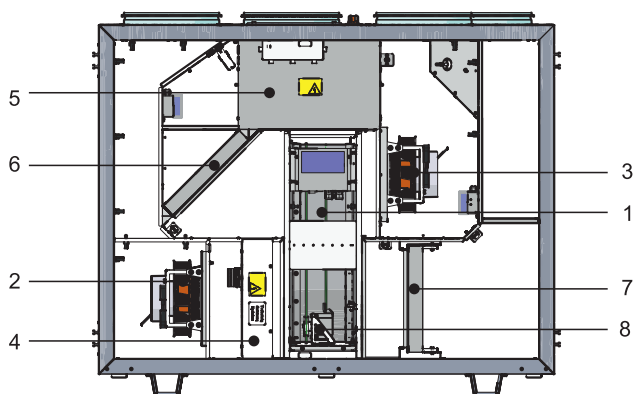

Figure 4.6.1. AmberAir Compact RIRS 1200-1900 V EKO 3.0

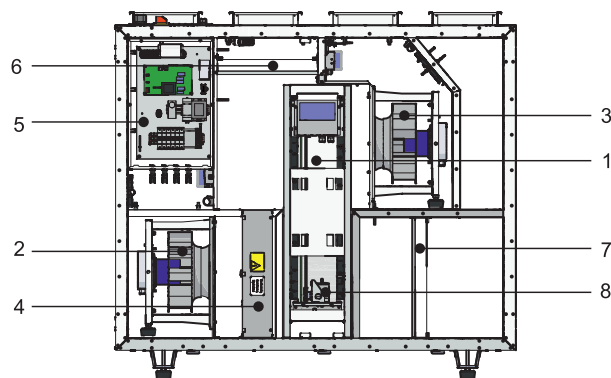

Figure 4.6.2. AmberAir Compact RIRS 2500 V EKO 3.0

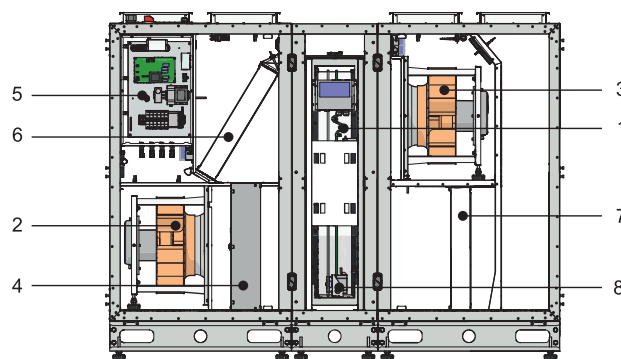

Figure 4.7. AmberAir Compact RIRS 3500-5500 V EKO 3.0

1 - Rotor heat exchanger; 2 - Supply fan; 3 - Exhaust fan; 4 - Electrical heater; 5 - Control board; 6 - Extract air filters (panel); 7 - Supply air filter (panel); 8 - Rotor motor.

## 5. INSTALLATION

### 5.1. RECEPTION OF GOODS

Each device is carefully checked before transportation. When receiving the goods, checking the devices for any damage made during transportation is recommended. If any damage to the unit is observed, immediately contact the representatives of a transport company. Please inform the representative of the manufacturer, if any deviation of the device is noticed.

### 5.2. TRANSPORTATION AND STORAGE

- All units are factory-packaged to withstand normal conditions of transportation.
- When unpacking, check the unit for any damage made during transportation. Installing of damaged units is not allowed!
- The packaging is used for protection purpose only!
- When unloading and storing the units, use suitable lifting equipment to avoid damage and injuries. Do not lift units by holding on power supply cables, connection boxes, air extract or exhaust flanges. Avoid hits and shock overloads. Before installation, the units must be stored in a dry room with the relative air humidity not exceeding 70% (at +20°C) and with an average ambient temperature ranging between +5 °C and +30 °C. The storage place must be protected against dirt and water.
- The units must be transported to the storage place or installation site using forklifts.
- The recommended storage period should not be longer than one year. In case of storing the units for a period longer than one year, checking if the fan bearings and motor rotate without difficulty (turning the impeller by hand) and if the electric circuit insulation is not damaged or the moisture has not accumulated must be performed before the installation of the unit.

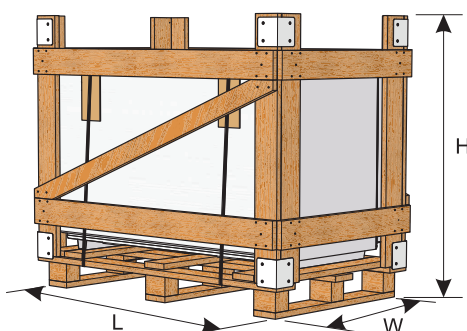

AMBERAIR COMPACT RIRS V EKO 3.0 RHX	H	W	L	MAX. NUMBER OF TRANSPORTED PACKAGES
	[mm]	[mm]	[mm]	[pcs.]
1200	1410	980	1620	1
1900	1410	980	1620	1
2500	1705	1020	1770	1
3500	1820	1135	2105	1
5500	1900	1440	2235	1

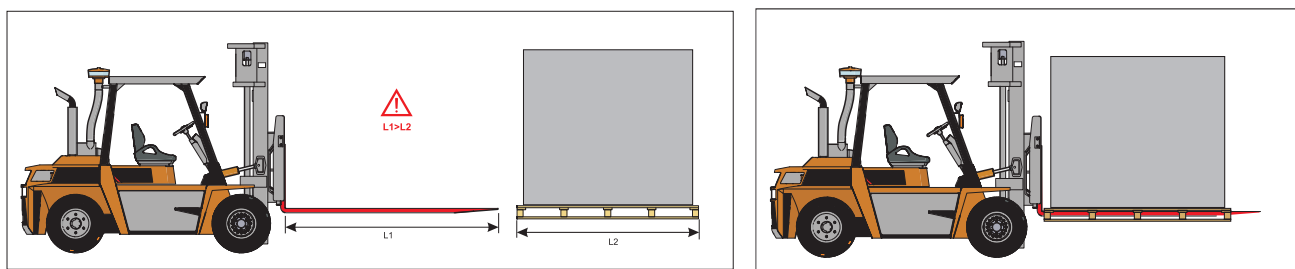

Figure 5.2.1. Lifting by forklift.

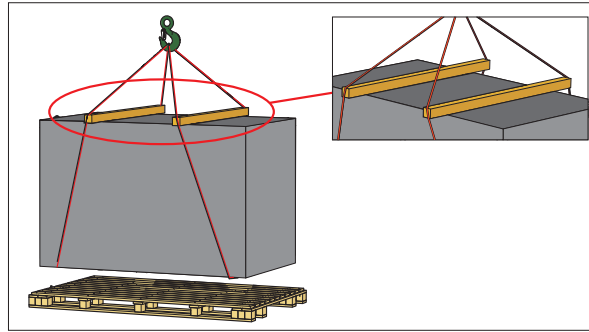

Figure 5.2.2. Lifting by rope



In order to prevent damage to the casing, only a product placed on a pallet should be lifted.

### 5.3. UNPACKING



Accessories may be packed together with the product. Prior to transporting the unit, the accessories should be unpacked first.

- Remove the film from the unit.
- Remove the bracing packaging tape that keeps the protective profiles in place.
- Remove the protective profiles.
- After unpacking the unit, examine it to make sure that no damage was made during transportation. Installing of damaged units is not allowed!
- Before commencing the installation of the unit, please check if all ordered equipment have been delivered. Any variation from the ordered equipment list must be reported to the product supplier.

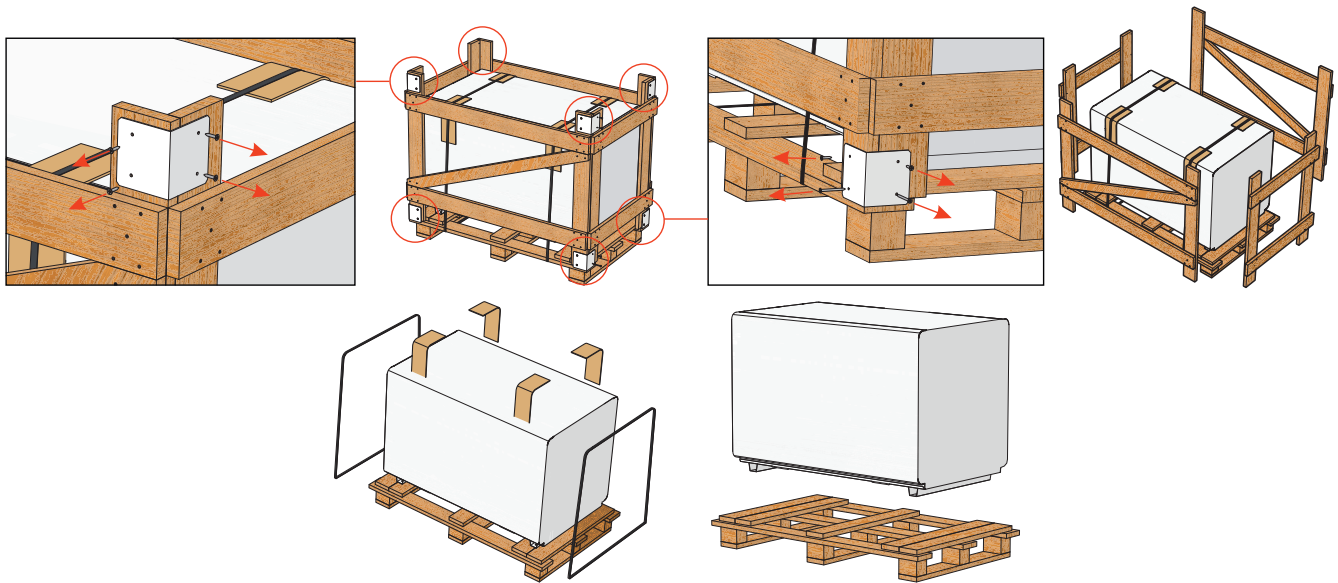

### 5.4. PIPING AND INSTRUMENTATION DIAGRAM

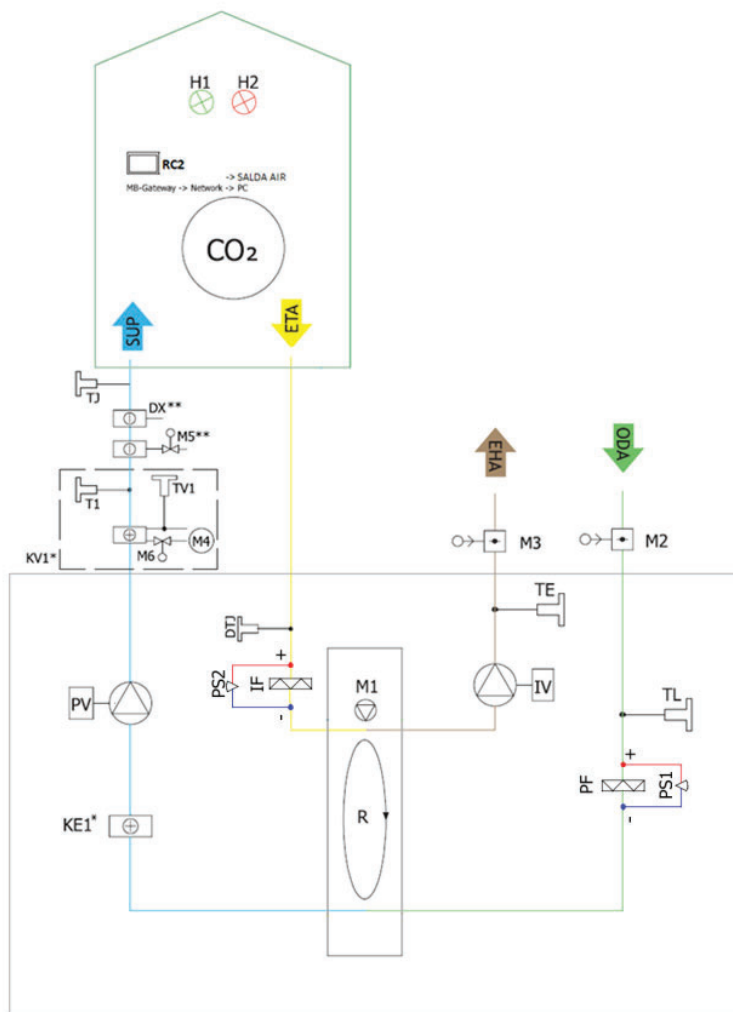

\* KE1 - only in electrical version; \* KV1 - used in water version; \*\* Possible to control.

#### THE LIST OF COMPONENTS

<b>PV</b>	Supply air fan	<b>IF</b>	Extract air filter
<b>PF</b>	Supply air filter	<b>IV</b>	Exhaust fan
<b>TE</b>	Exhaust air temperature sensor	<b>TJ</b>	Supply air temperature sensor
<b>DTJ</b>	Extract air temperature and humidity sensor	<b>CO<sub>2</sub></b>	CO <sub>2</sub> sensor
<b>PC</b>	Computer	<b>KE1</b>	Electric heater*
<b>M2</b>	Outdoor air damper actuator	<b>M3</b>	Exhaust air damper actuator
<b>TL</b>	Outdoor air temperature sensor		Ventilated premises
<b>MB-Gateway</b>	Network module	<b>NET</b>	Network
<b>R</b>	Rotor heat exchanger	<b>DX</b>	DX cooler
<b>KV1</b>	Water heater*	<b>T1</b>	Water heater thermostat*
<b>M4</b>	Water heater circulation pump*	<b>M5</b>	Water cooler valve motor
<b>RC2</b>	Stouch, Flex or ST-SA-Control remote control panel	<b>M6</b>	Water heater valve motor*
<b>TV1</b>	Water heater temperature sensor*	<b>M1</b>	Rotor motor
<b>PS1</b>	Supply air filter differential pressure sensor	<b>PS2</b>	Extract air filter differential pressure sensor

\* Component/possibility to connect it depends on model.

#### POSSIBLE PCB INPUTS/OUTPUTS

<b>FA</b>	Fire alarm	<b>H1</b>	Working indication output
	System mode switch (START/STOP)	<b>H2</b>	Alarm indication output
	Fans speed switch (BOOST)		

## 5.5. MOUNTING

- Installation should be carried out by qualified and trained staff only.
- When connecting air ducts, consider the labels on the casing of the unit.
- Before connecting to the air duct system, the connection openings of ventilation unit should be closed.
- When connecting the ducts, the air-flow direction indicated on the device housing should be observed.
- Do not connect the bends close to connection flanges of the unit. The minimum distance of the straight air duct between the unit and the first branch of the air duct in the supply air duct must be  $1xD$ , in air exhaust duct  $3xD$ , where  $D$  is the diameter of the air duct.
- It is recommended to use the brackets (accessories). This will reduce the vibration transmitted by the unit to the air duct system and environment.
- Sufficient space must be provided for opening of the manhole and filter covers.
- If the ventilation unit is wall-mounted wall, it may transmit noise vibrations to the premises. Though the level of noise generated by the fans is admissible, mounting the unit at the distance of 400 mm from the nearest wall is recommended. Where this is not possible, mounting of the unit on the wall of the room where the level of noise is not significant is recommended.
- Ducts are connected to the unit in such way that they could be easily disassembled and the heater could be removed from the unit when carrying out maintenance, servicing and/or repairs



**The protective film is used to protect the unit during transportation. It is recommended to remove the film; otherwise, oxidation signs may occur.**

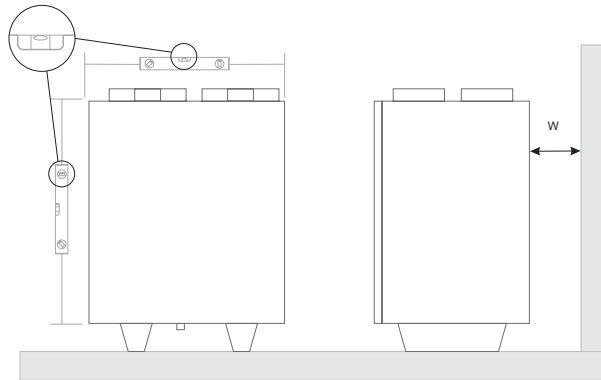

Figure 5.5.1. Horizontal floor-mounting positions on floor ( $W=400$  mm)

### 5.5.1. UNIT PLACING AND MOUNTING POSITIONING REQUIREMENTS

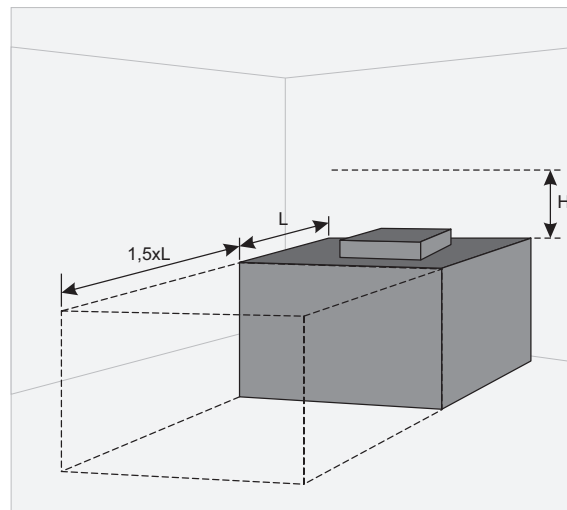

Figure 5.5.1.1. Min. distance to open the door -  $1,5xL$ ; Min. distance to open the control box door -  $H > 400$  mm.

### 5.5.2. FLOOR MOUNTING

- The installation should be performed having positioned the units in horizontal direction only.
- Install the supporting legs.
- The units are assembled from separate sections.
- They must be adjusted without a gradient.
- Leave space in front ( $2xL$ ) so that it would be sufficient to open the doors and to remove or install a required component.

## 5.6. CONNECTION OF THE AIR DUCT

- The connected air ducts must not be bent and have separate fixing.

- Make sure that the fans can not be accessed through air duct heads. Otherwise, protective grid should be installed. You may choose the grid from the range of products provided in our website.
- Do not reduce the diameter of the piping near air inlet or exhaust ducts. If you want to reduce the airflow speed in the system, drop of pressure and noise level, you can increase the diameter.
- In order to reduce the level of the noise in the air supply system, install dampers (see the chapter on air supply system installation).
- In order to reduce air loss in the system, the air ducts and profile components should be of class C and higher. The catalogue on the above-mentioned items can be found in our website.
- External air and exhaust system piping should be isolated in order to prevent heat loss and condensation.
- Maintaining the distance of up to 8 meters between air intake and air exhaust ducts is recommended. Air supplying system should be installed away from potential air pollution sources.
- When installing air ducts next to the ventilation equipment, brackets must be used. They suppress vibration and assure secure installation of the various system parts. The necessary brackets can be found in our catalogue or website.
- Air ducts are often mistakenly connected in inappropriate location. The ventilation units bear the labels indicating the correct air duct connection layout. Before starting up the system, carefully check if all related works have been performed properly.

 For flange diameters see chapter "DIMENSIONS AND WEIGHT".

## 5.7. CONNECTION OF THE UNIT TO ELECTRIC NETWORK

- Supply voltage to the unit must be connected by a qualified specialist following the manufacturer's instructions and applicable safety guidelines.
- The unit's power network voltage must correspond to electro technical specifications of the unit indicated in the technical decal.
- The unit's voltage, power and other technical specifications are provided in the unit's technical decal (on the unit casing). The unit must be connected to the voltage plug socket of the grounded power network in accordance with the applicable requirements.
- The unit must be earthed according to electrical equipment installation regulation.
- Using extension wires (cables) and power network plug socket distribution devices is not allowed.
- Prior to carrying out any ventilation unit installation and connection works (before the unit is commissioned), the unit must be disconnected from the power network.
- After installation of the ventilation unit, the power network plug socket must be accessible at any time. If the unit is equipped with circuit breaker, disconnection from the power network is performed through the two-pole or four-pole circuit breaker (by disconnecting phase poles and neutral).
- Before it is connected to the power network, the unit must be carefully checked for any damage (execution, control, and measurement nodes) made during transportation.
- The power cable can be replaced only by a qualified technician, having evaluated the rated power and current.

 The manufacturer does not assume any liability for personal injuries and property damage due to nonconformance with the provided instructions.

## 5.8. START-UP RECOMMENDATIONS

### 5.8.1. SYSTEM PROTECTION

The control board of the unit is equipped with the following integrated devices for the protection against short circuit:

AmberAir Compact RIRS EKO 3.0 RHX	1200 VE	1200 VW	1900 VE	1900 VW	2500 VE	2500 VE 3X230	2500 VW	3500 VE	3500 VE 3X230	3500 VW	5500 VE	5500 VW
<b>F1</b>	2A	2A	10A	10A	5A	-	5A	10A	-	1A	6,3A	6,3A
<b>Q3 (F2)</b>	10A	10A	-	1A	10A	10A	1A	-	16A	5A	32A	1A
<b>Q2 (F3)</b>	16A	1A	16A	-	16A	25A	10A	20A	25A	16A	10A	10A

It is recommended to use the unit with external electrical protection device.

AmberAir Compact RIRS EKO 3.0 RHX	1200 VE	1200 VW	1900 VE	1900 VW	2500 VE	2500 VE 3X230	2500 VW	3500 VE	3500 VE 3X230	3500 VW	5500 VE	5500 VW
<b>Mains Fuse</b>	25 A	10 A	25 A	10 A	25 A	40 A	10 A	40 A	40 A	16 A	40 A	10 A

 To ensure safe maintenance of the unit, it is necessary to turn off main switch and/or external protection device.

### 5.8.2. PRE-STARTUP RECOMMENDATIONS OF THE UNIT (IN THE PRESENCE OF THE END-USER)

Prior to start-up the system must be thoroughly cleaned. Check whether:

- operation systems and unit elements as well as automation and automation devices were not damaged during installation,
- all electrical devices are connected to power supply and fit for service,
- all necessary automation elements are installed and connected to power supply and terminal blocks,
- cable connection to terminal blocks comply with the existing wiring diagrams,
- all electrical equipment protection components are properly connected (if they are additionally used),
- cables and wires correspond to all applicable safety and functional requirements, diameters, etc.,
- earthing and protection systems are properly installed,
- condition of all seals and sealing surfaces is proper.

## 6. MAINTENANCE

### 6.1. SAFETY INSTRUCTION



Unplug the unit from the mains before opening the door (disconnect the power plug from the outlet or in case an automatic circuit breaker installed, disconnect it as well. Make sure that it cannot be turned on by third parties) and wait until the fans completely stop (for about 2 min.).

### 6.2. GENERAL RECOMMENDATIONS FOR VENTILATION SYSTEM MAINTENANCE

In order to ensure proper functioning of the system, maintenance requirements and its periods should be observed. Otherwise, the warranty shall be void. Some recommendations are provided in the table below, but they are just advisory, as the need for system maintenance depends on the location of the unit installation, the pollution of atmosphere, population, working hours, etc.

COMPONENT	DURING START-UP	AT LEAST EVERY 6 MONTHS
Filters	Check the cleanliness of the filters	Replace filters every 3 to 4 months or according to the control device indications. Check cleanliness. Clean, if necessary Make sure that the impellers are not unbalanced.
Fans	Check the connections and the direction of rotation	Make sure that the impellers do not cause noise when rotated by hand. Make sure that the fastening screws are not loose and free of mechanical damage. Check electrical connections and make sure that these are secured properly and are free of signs of corrosion.
Rotor heat exchanger	Check the cleanliness of the heat exchanger	Check cleanliness and clean, if necessary Check the tension of a belt
Control panel	Check the connections	Check the connections
Electric heater	Check the connections	Clean off dust, and check the electrical components and connections of the heater
Temperature sensor	Check electrical connections	Check the operation.
Air supply and extract system	Check the connections	Clean
Air duct system	Check the tightness	Clean
Dampers, diffusers, grid	Check the tightness of connections	Clean
Switching unit (contactor)		Every 3 to 4 months, visually assess the functioning of the switching unit (contactor), i.e. make sure that its casing has no signs of melting or is not thermally damaged otherwise and does not produce any unusual sounds. All the contactors in the product or in its accessories must be checked.

### 6.3. COVER OPENING

Before opening the covers, first, unplug the unit from the mains, then wait for 2 minutes (until the fans completely stop).

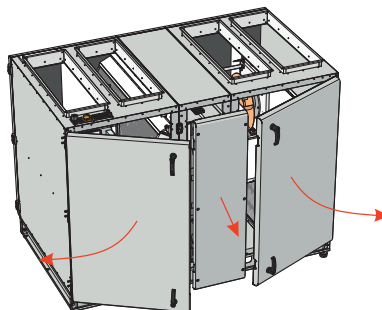



## 6.4. FILTERS MAINTENANCE

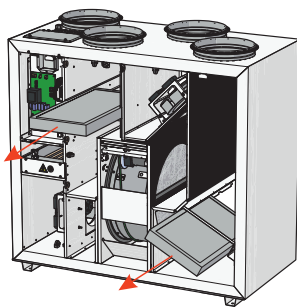

In order to remove the filters, open unit door and take off the filters.

Dirt increases air resistance in the filter, therefore, lower amount of air is supplied into the premises. Arrows on the filters must comply with airflow direction.



**After changing the filters, please reload the filter timer. The instruction on reloading can be found in the control panel operation manual or on our website [www.salda.it](http://www.salda.it)  
Operation of the unit without filters is not allowed.**



**Change the filters every 3-4 months or according to the notification on the control device.**

## 6.5. ROTOR MAINTENANCE

- Maintenance of rotor heat exchanger must be performed on annual basis, once per year.
- Ensure the gaps of heat exchanger are clean, the brushes are not worn, the belt drive is not worn, and the clamping nodes of the rotor heat exchanger are tight.
- Rotor heat exchanger can be easily removed from the unit. Disconnect the power cord of the motor of heat exchanger, release and raise the clamp of the rotor heat exchanger section, and then remove the heat exchanger.
- Heat exchanger must be cleaned using the solution of warm water and non-corrosive toward aluminium alkaline agent or an air stream. Applying direct stream of liquid is not recommended, because this can cause damage to the device.
- While cleaning, make sure that no moisture and liquid will enter into the motor of the heat exchanger.
- Having reinstalled the heat exchanger, fasten its section with the clamp. Connect the heat exchanger motor.

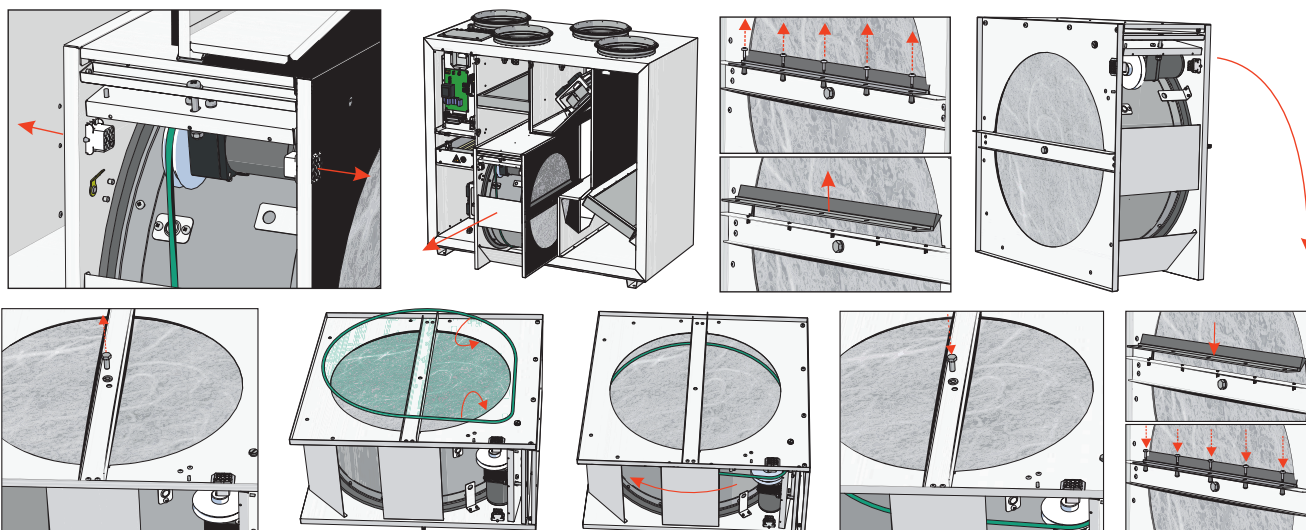

**CAUTION: heat exchanger cannot be used when the filters are removed!**

## 6.6. FANS MAINTENANCE

- Fan maintenance should be performed by experienced and trained staff only.
- The fan should be inspected and cleaned at least once per year.
- Prior to commencing any maintenance or repairs, make sure the fan is disconnected from the power source.
- Proceed to maintenance and repair after any fan rotation is stopped.
- Observe staff safety regulations during maintenance and repairs.
- The motor features a heavy-duty ball bearing design. The motor is completely sealed and grease-free.
- Detach the fan from the unit.
- The impeller should be particularly checked for built-up material or debris that may cause an imbalance. Excessive imbalance may lead to accelerated wear on motor bearings and vibration.
- Clean impeller and inside housing with mild detergent, water and damp, soft cloth.
- Do not use high-pressure cleaner, abrasives, sharp tools or caustic solvents that may scratch or damage the housing and impeller.

- Do not plunge the motor into any fluid while cleaning the impeller. Make sure the impeller's balance weights are not moved.
- Make sure the impeller is free of any obstacles.
- Install the fan back into the unit. Connect fan power and control signals.
- In case the fan after maintenance does not automatically start up or stop, contact the manufacturer. Malfunction of the fan can be identified by the pressure in the system (when pressure switches are connected). In case of any fault in the fan motor, a notice will appear on the control panel.

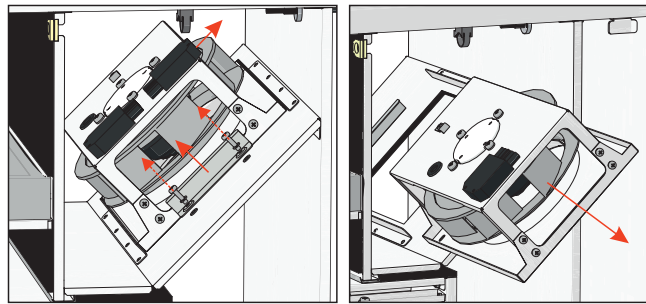

**Prior to commencing any maintenance or repairs, make sure the unit is disconnected from the power source.**

### 6.7. HEATER MAINTENANCE

- In case manual protection is activated, check for a fault before pressing the RESET button. If the fault is identified after it has been rectified, press the RESET button using a screwdriver or a similar object.
- Electrical heater does not require additional servicing. The filters must be replaced as described above.
- Heaters are equipped with 2 thermal protection devices: an automatic self-resetting protection device that is activated at +50 °C, and a manually restored protection device that is activated at +100 °C.
- After an activation of the manually restored protection device, make sure the unit is disconnected from the power supply. Wait until all heating elements cool down and the fans completely stop. Having identified and rectified the failure, to start the unit, press the RESET button. The failure can be identified by a qualified technician only.
- If necessary, electric heater can be removed. Disconnect the electrical connector from the heater and remove the heater.

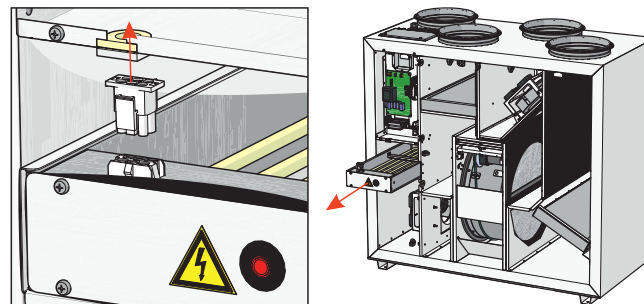

### 6.8. CONTROL BOARD MAINTENANCE

- Disconnect product unit from electric power source.
- Open the cover of the product.
- Unscrew the bolts on the control box.
- Remove the control box cover.
- Disconnect all cables, wires, and connectors from the control board and unscrew the control board mounting bolts.
- Remove control board.
- To reassemble, follow all maintenance steps in reverse order. When re-connecting cables, wires, and connectors, make sure to match each wire and connector to corresponding connection terminal and connector.

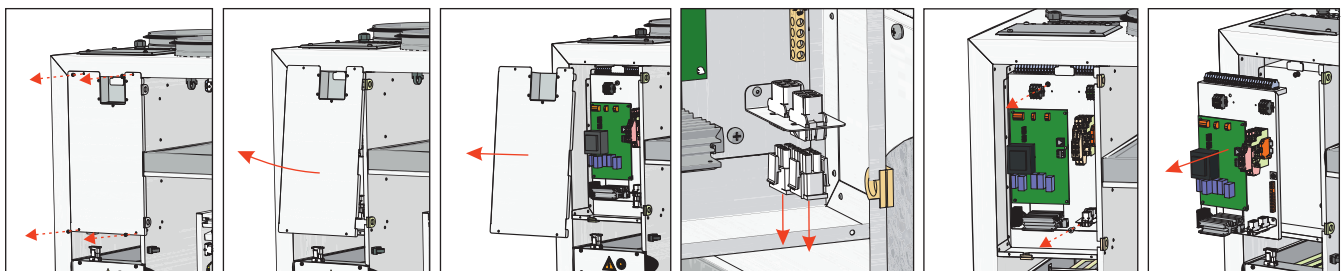

## 7. CONTROL

### 7.1. DEVICE CONTROL

Ventilation unit equipped with PRV control board can be controlled with remote controller, WEB interface or mobile app via MB-GATEWAY and BMS (building management system). More information provided in the table below.

With MB-GATEWAY	Remote control panels	BMS direct connection	Wireless communication
Web interface	Stouch	Modbus RTU (RS485)	MB-GATEWAY + WIFI router
SALDA AIR mobile application	ST-SA-Control		
BMS over Modbus TCP/IP	FLEX		
BMS over BACnet TCP/IP			

### 7.2. DEVICE FUNCTIONS

PRV control board operation functions and control of the device depends on the following:

1. Selected control interface (remote control panel, MB-GATEWAY, etc.). The selected interface affects access to the information and settings, however, it does not affect the logic of control. Full access to the information and settings is available on FLEX, ST-SA-Control, MB-GATEWAY WEB application and SALDA AIR mobile application.
2. Unit configuration (internal/external components, sensors and control board settings).



**Refer to the instruction manual of the existing control device for unit control instructions.**

## 8. CONNECTION OF ACCESSORIES

### 8.1. FIRE PROTECTION SIGNAL INPUT (FIRE PROTECTION INPUT (NC))

Fire protection signal input must be normally closed, until the fire protection system is not connected a jumper is installed in the factory.

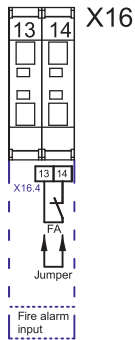

### 8.2. EXTERNAL CO<sub>2</sub> /PRESSURE SENSORS

AmberAir Compact RIRS V EKO 3.0 units have two connections for external CO<sub>2</sub>/PRESSURE (input 0-10 VDC) sensors

**Sensors connection:**

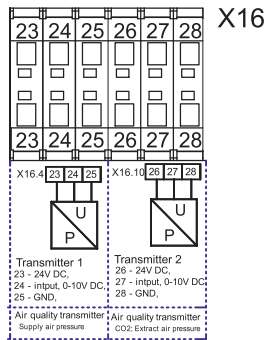

These sensors are intended for the following 3 functions: supply air pressure, extract air pressure and extract CO<sub>2</sub> detection. Supply air pressure is measured inside the supply air duct referenced to the unit's surrounding area. Extract air pressure is measured inside the extract air duct referenced to the unit's surrounding area. The CO<sub>2</sub> transmitter is installed in the extract air duct or room.

### 8.3. ROOM CO<sub>2</sub> TRANSMITTER INSTALLATION RECOMMENDATION

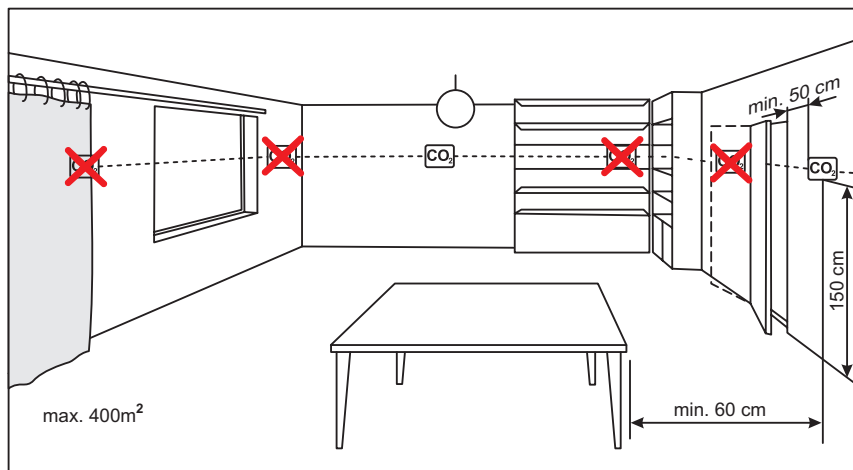

If the duct CO<sub>2</sub> transmitter is used, it must be installed in the extract air duct. To install duct transmitters, hole drilling tools are required .

### 8.4. CO<sub>2</sub> CONCENTRATION ACCORDING TO PETTENKOFER LIMIT

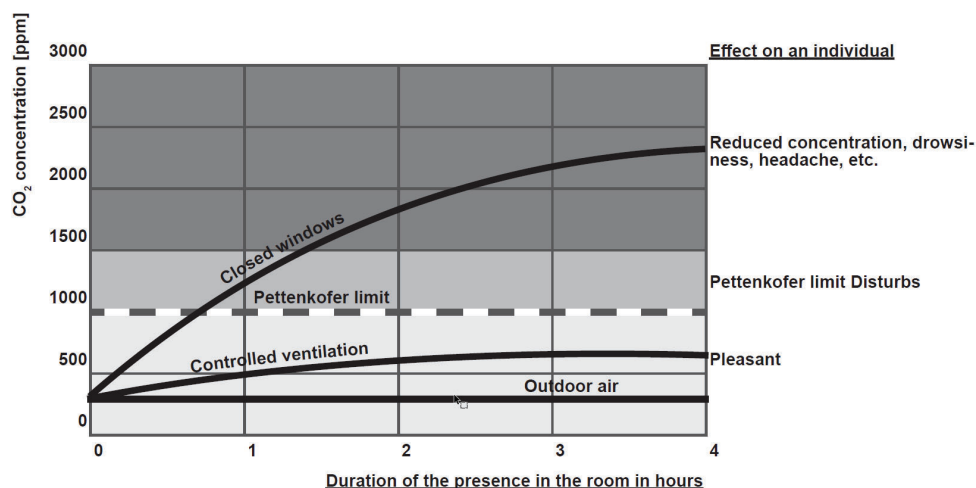

### 8.5. CONNECTION OF SUPPLY AND EXTRACT AIR DAMPERS

Product AmberAir Compact RIRS V EKO 3.0 can be equipped with supply air and extract air dampers. Dampers are controlled by Open/Close or Spring-return actuators.

#### Wiring diagram for AmberAir Compact RIRS VE EKO 3.0

M2, M3 – Open/Close damper actuators. Upon activation of outputs X16:17, X16:20 the dampers shall open, Upon activation of outputs X16:16, X16:19 the dampers shall close.

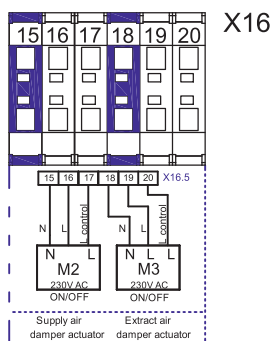

#### Wiring diagram for AmberAir Compact RIRS VW EKO 3.0

M2 – Spring-return damper actuator. M3 – Open/Close damper actuator. Upon activation of outputs X16:17, X16:20, the dampers open, Upon activation of output X16:19, the extract air damper close. The supply air damper is controlled by spring-return actuator so that when output X16:16 is deactivated, the supply air damper closes.

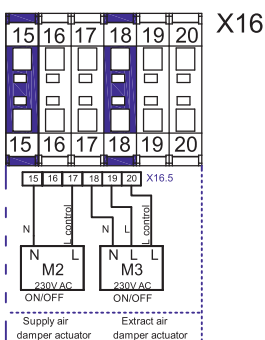

### 8.6. CONNECTION OF REMOTE CONTROL PANEL OR MODBUS

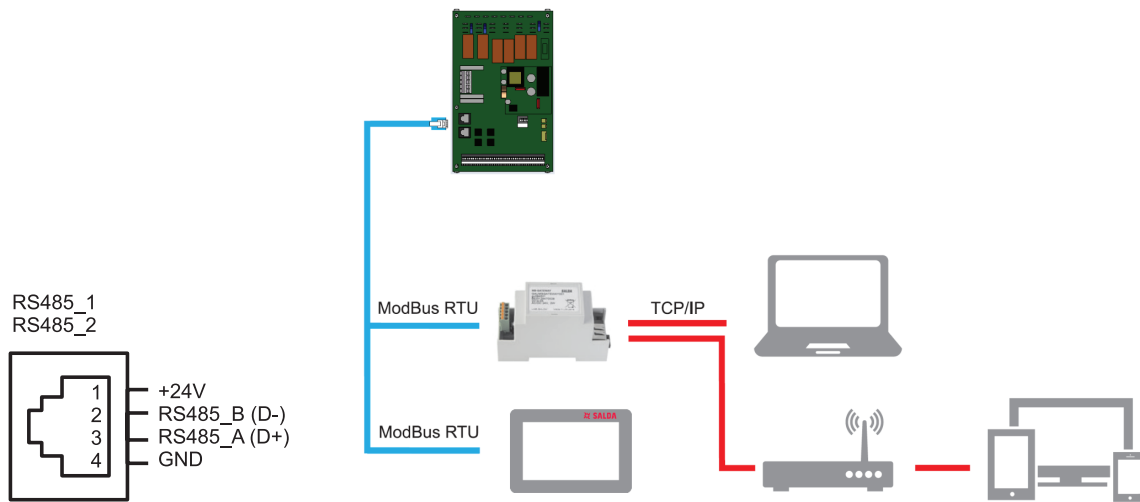

### 8.7. WATER HEATER CIRCULATION PUMP AND VALVE ACTUATOR

Water heater circulation pump and valve actuator can only be connected to the units that are designed to operate with water heater (AmberAir Compact RIRS VW EKO 3.0 units).

#### Wiring diagram

Valve actuator is controlled by 0-10 VDC signal. Circulation pump is controlled by On/Off signal.

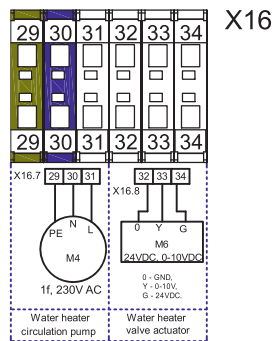

8.8. RECOMMENDED SCHEME FOR CONNECTION OF INTERNAL AND EXTERNAL COMPONENTS

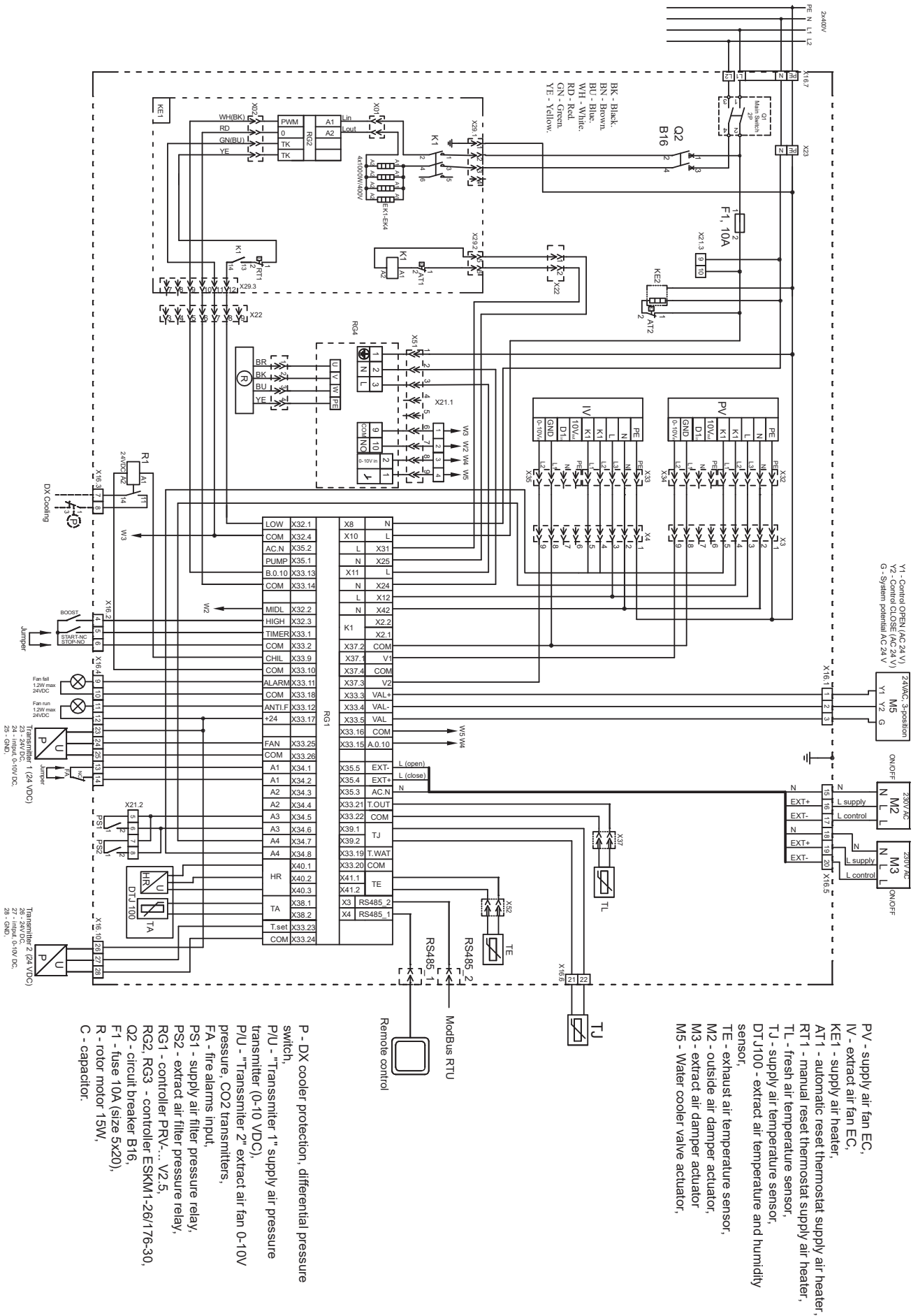

Figure 8.8.1. AmberAir Compact RIRS 1200 VE EKO 3.0

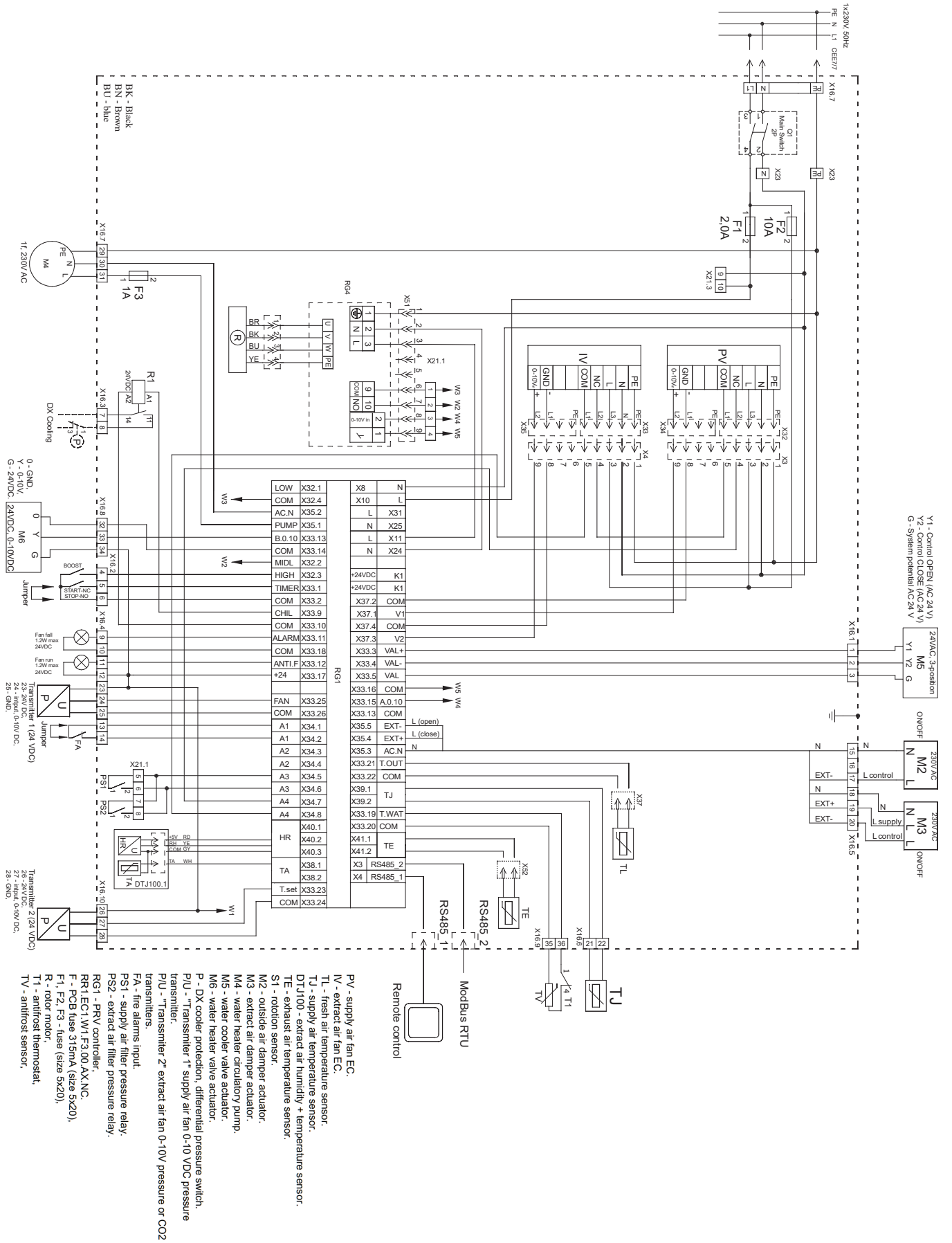

Figure 8.8.2. AmberAir Compact RIRS 1200 VW EKO 3.0



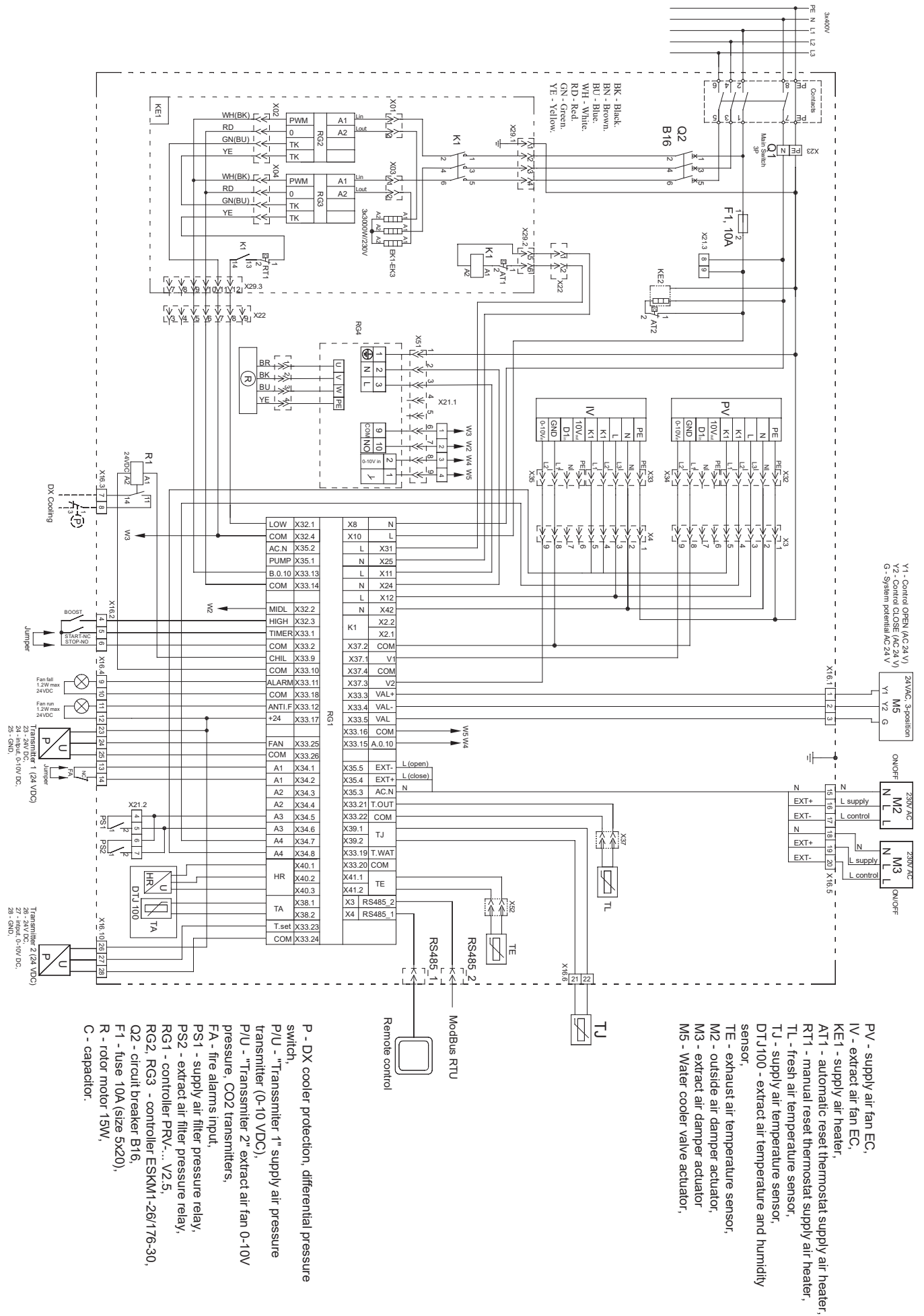

Figure 8.8.3. AmberAir Compact RIRS 1900 VE EKO 3.0

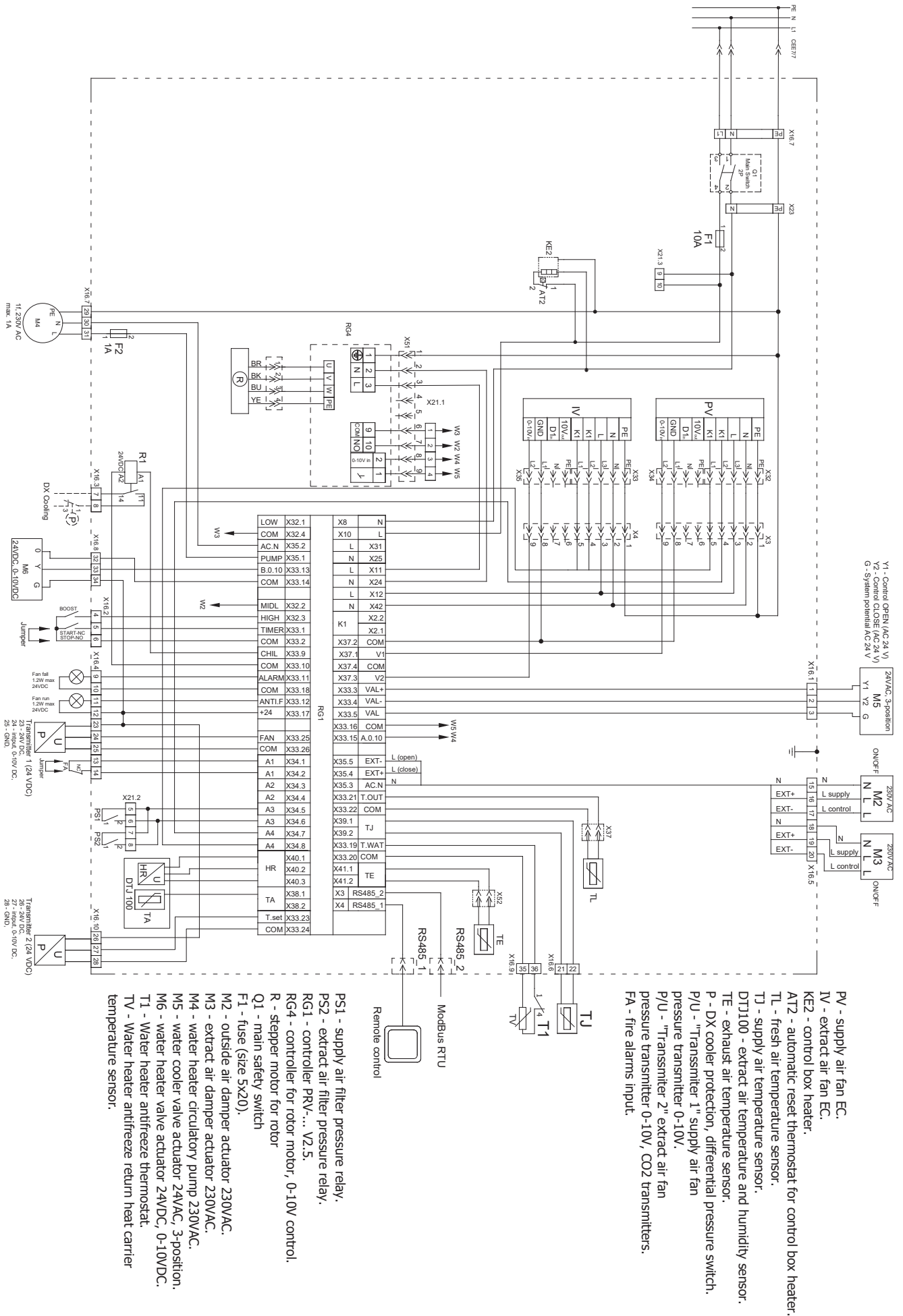

Figure 8.8.4. AmberAir Compact RIRS 1900 VW EKO 3.0

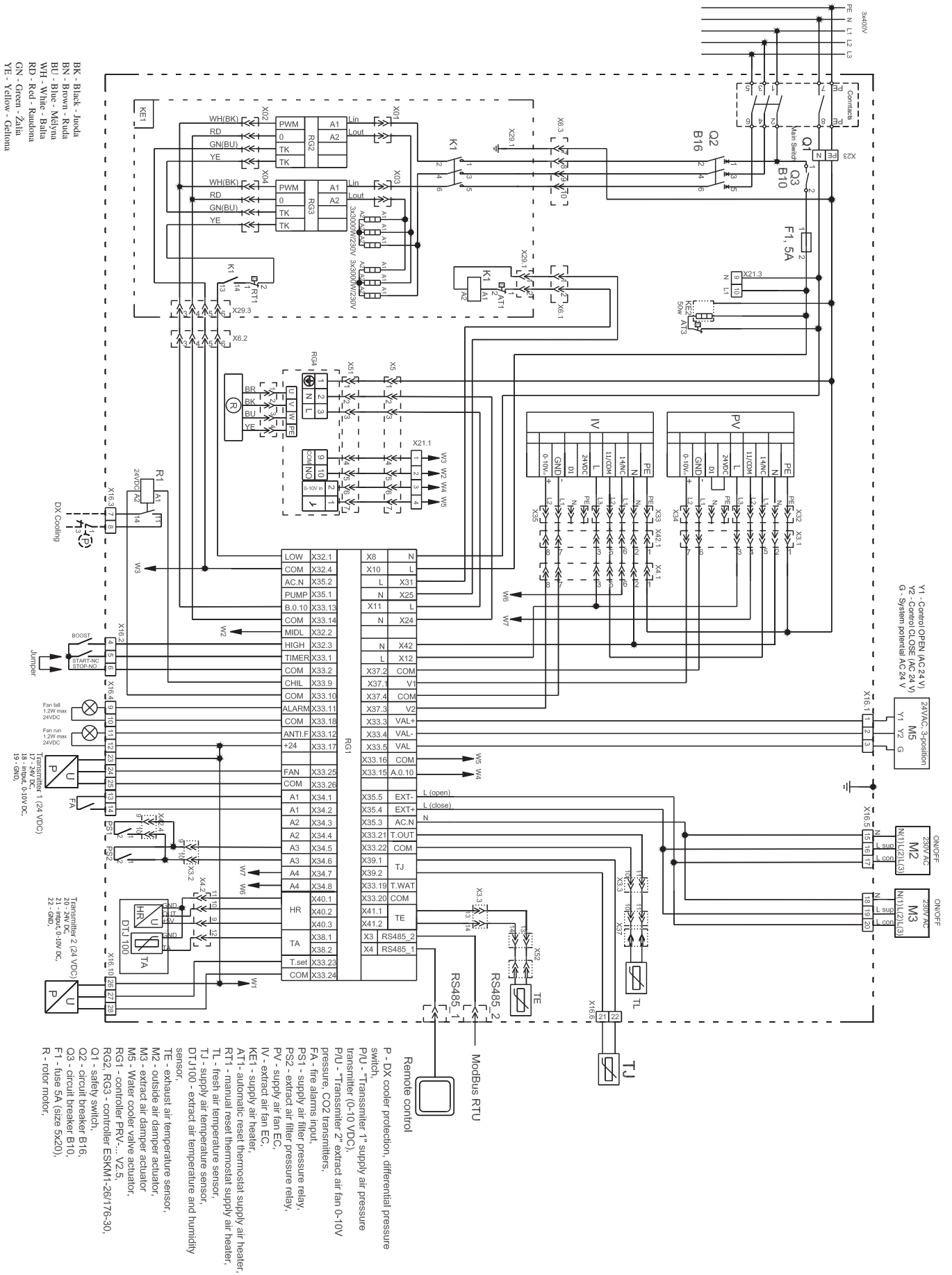
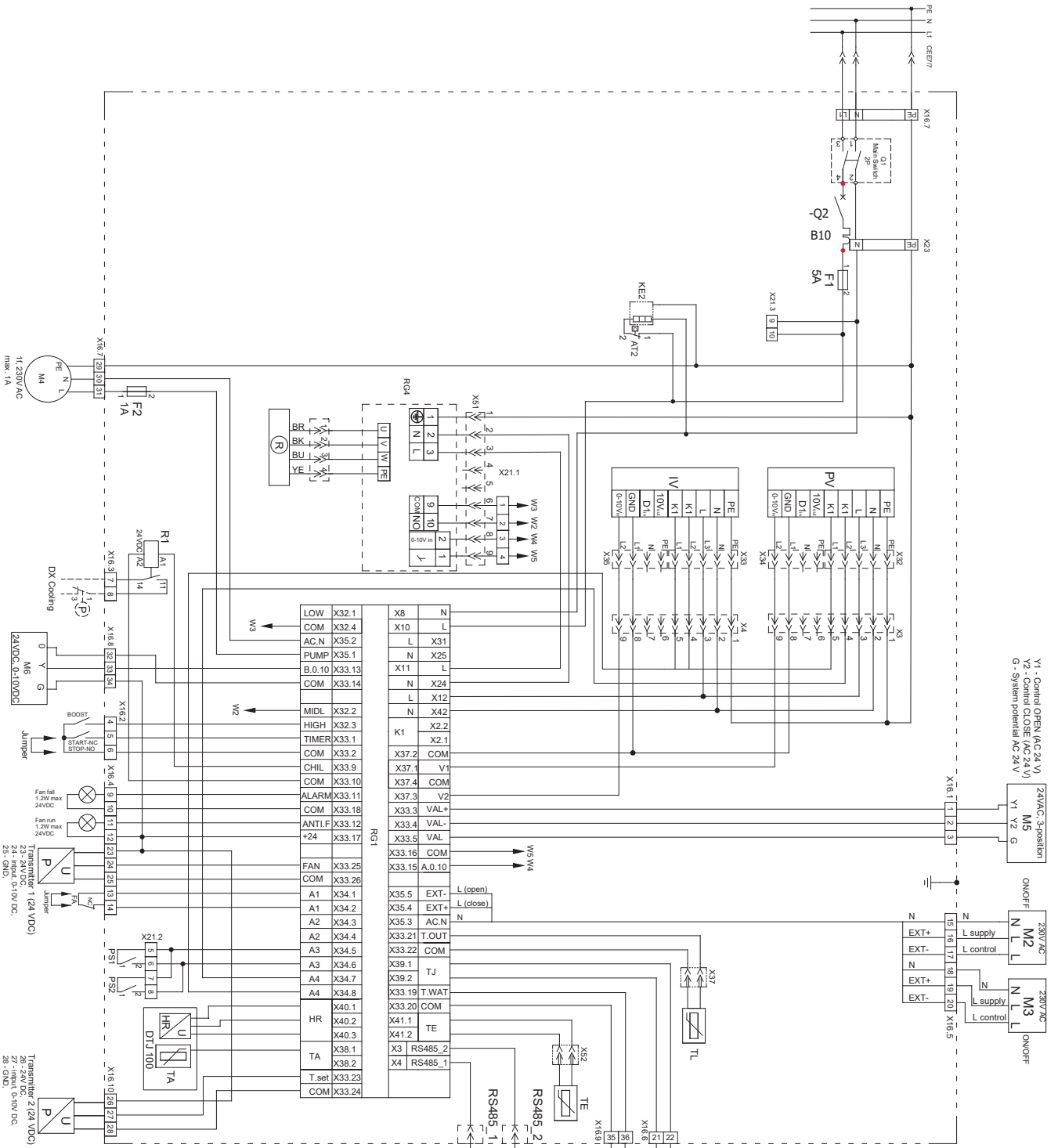

Figure 8.8.5. AmberAir Compact RIRS 2500 VE EKO 3.0



- PV - supply air fan EC,
- IV - extract air fan EC,
- KE2 - control box heater,
- AT2 - automatic reset thermostat for control box heater,
- TL - fresh air temperature sensor,
- TJ - supply air temperature sensor,
- DTJ100 - extract air temperature and humidity sensor,
- TE - exhaust air temperature sensor,
- P - DX cooler protection, differential pressure switch,
- P/U - "Transmitter 1" - supply air fan pressure transmitter 0-10V,
- P/U - "Transmitter 2" - extract air fan pressure transmitter 0-10V, CO2 transmitters,
- FA - fire alarms input,
- PS1 - supply air filter pressure relay,
- PS2 - extract air filter pressure relay.

Figure 8.8.6. AmberAir Compact RIRS 2500 VW EKO 3.0

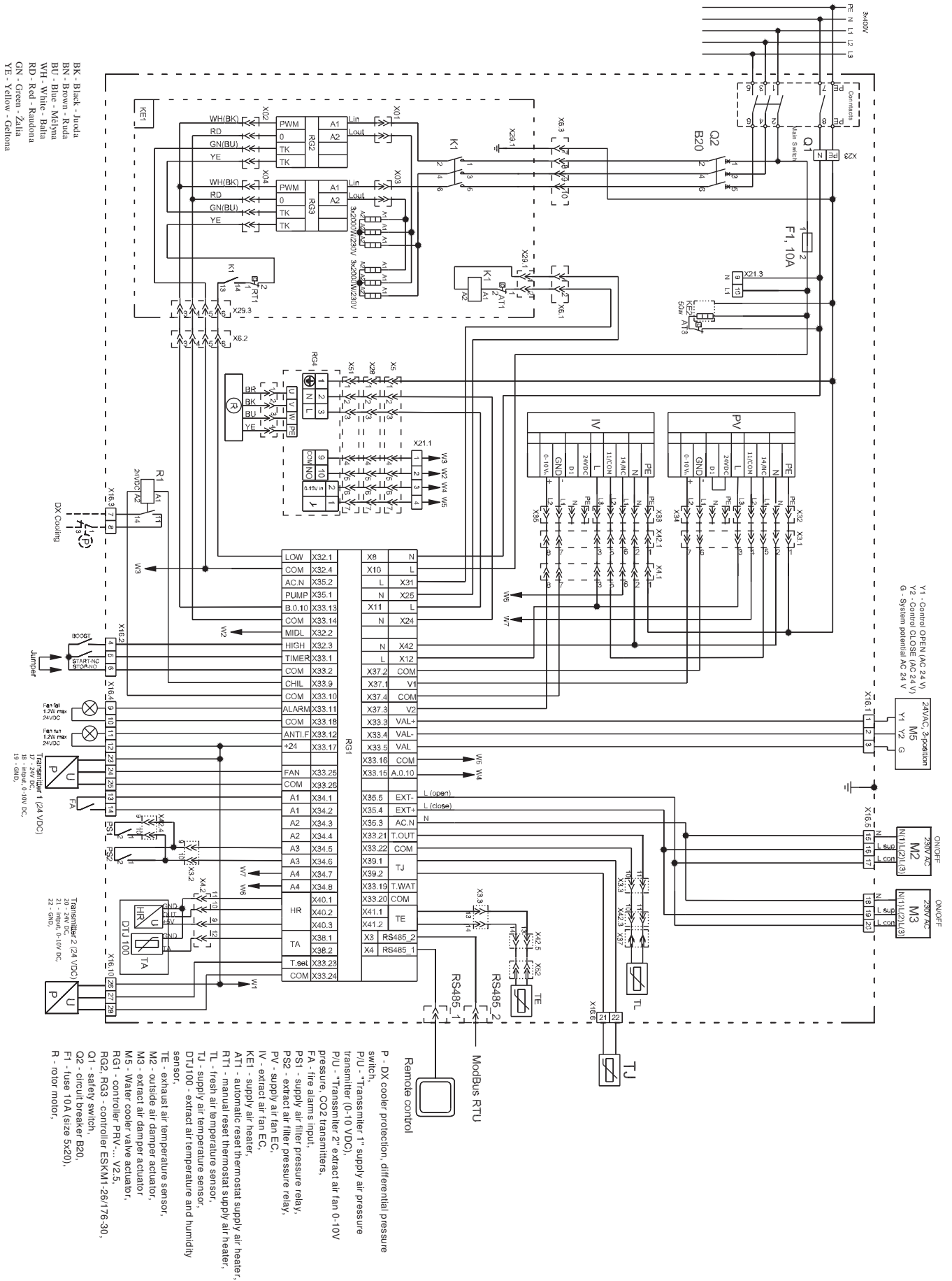

Figure 8.8.7. AmberAir Compact RIRS 3500 VE EKO 3.0

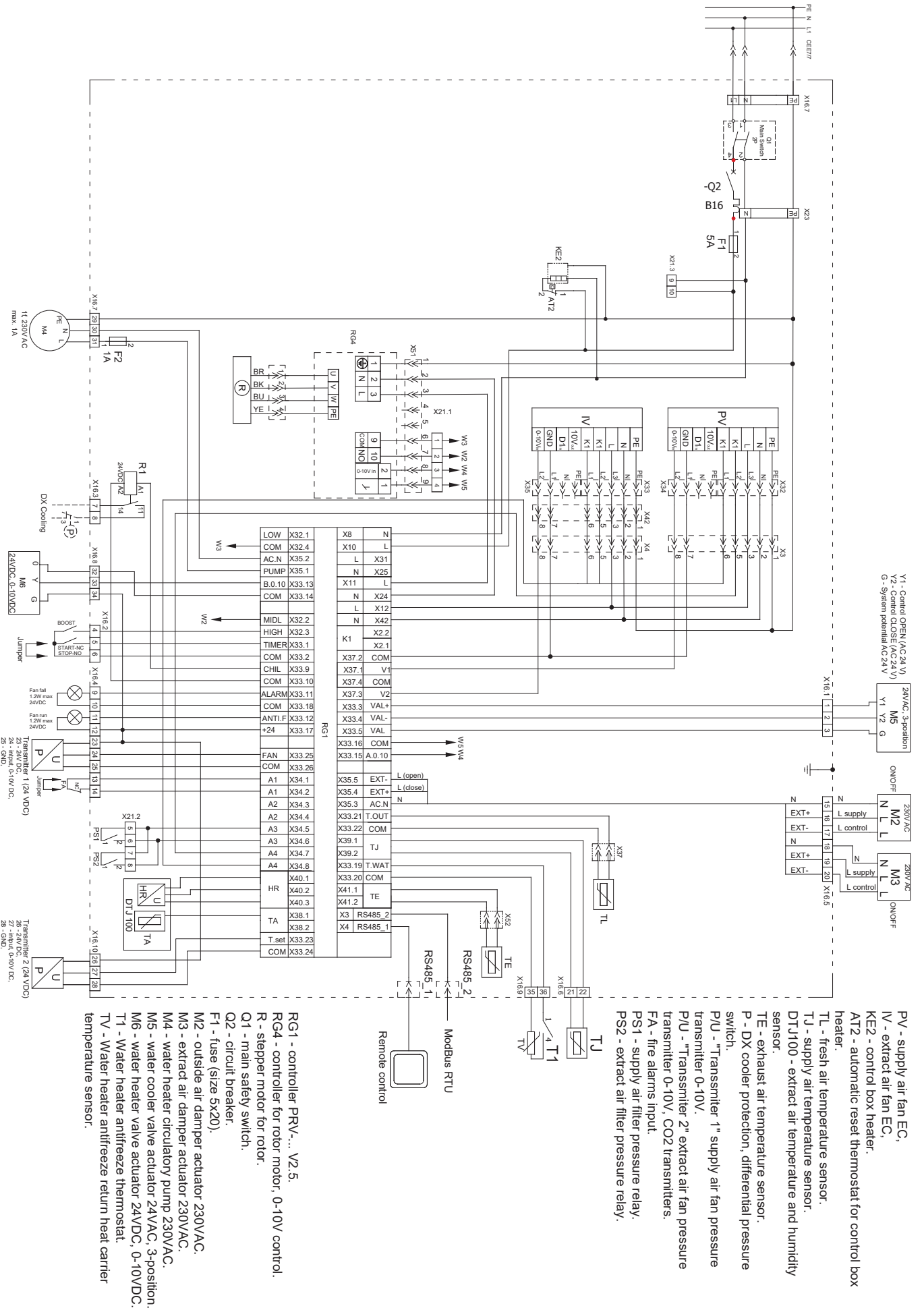

Figure 8.8.8. AmberAir Compact RIRS 3500 VW EKO 3.0



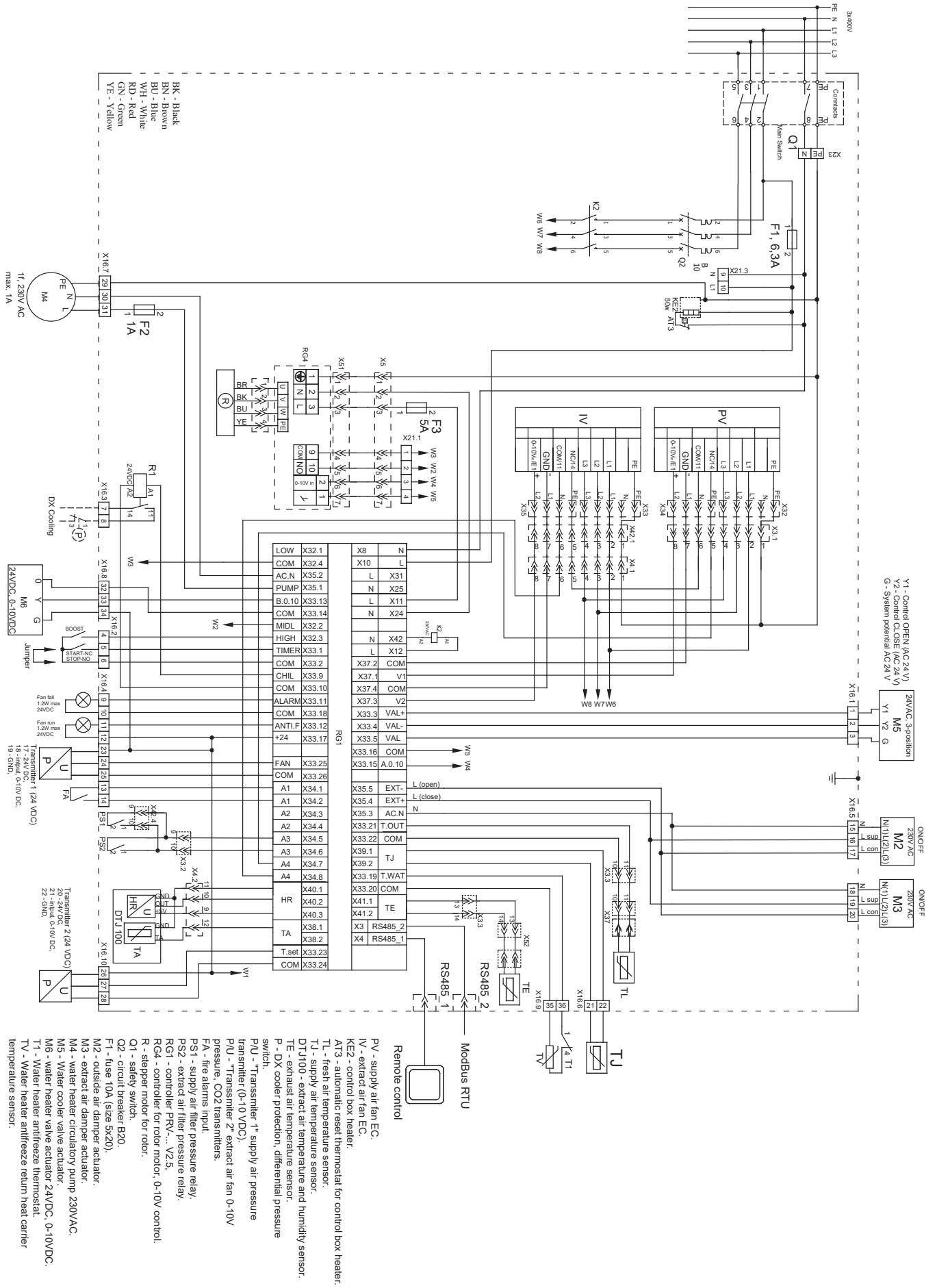

Figure 8.8.10. AmberAir Compact RIRS 5500 VW EKO 3.0



## 9. POSSIBLE FAULTS AND TROUBLESHOOTING

FAILURE	CAUSE	EXPLANATION / CORRECTIVE ACTIONS
Unit is not operating	No supply voltage	Check whether the device is connected to the power network
	Protection device is off or a current leakage relay is active (if installed by the installer)	Switch on only if the unit condition has been evaluated by a qualified electrician. If the system failed, the failure <b>MUST BE</b> rectified prior to switching it on.
Air supply heater or pre-heater is not operating or malfunctioning (if installed)	Too low air flow in air ducts activates automatic protection	Check if air filters are not clogged Check if fans are rotating
	Manual protection is activated	Possible heater or unit failure. <b>MUST</b> contact the servicing staff for failure detection and its elimination.
Too low air flow at rated fan speed	Clogged supply and/or extract air filter(s)	Filter replacement needed
Filters are clogged and no message is shown on the remote control	Wrong time in filter timers or their switch is broken, or its pressure is set improperly.	Shorten filter timer time till the message of clogged filters or replace the pressure switch of the filters, or set their proper pressure.
Rotor is not rotating	Rotor belt is broken	Inspect the rotor belt. If it is broken then it should be changed or re-welded.
Rotor belt failure	Rotor belt is slipping	If belt is not broken, check its tightness and adjust, if necessary.

## 10. ECODESIGN DATA TABLE

<b>AMBERAIR COMPACT RIRS EKO 3.0</b>		<b>1200 VE</b>	<b>1200 VW</b>	<b>1900 VE</b>	<b>1900 VW</b>
Declared typology		Bidirectional	Bidirectional	Bidirectional	Bidirectional
Type of drive		Variable	Variable	Variable	Variable
Type of HRS		Regenerative	Regenerative	Regenerative	Regenerative
Thermal efficiency of heat recovery	[ % ]	75,3	75,3	73	73
Nominal NRVU flow rate	[ m <sup>3</sup> /s ]	0,36	0,36	0,41	0,41
Effective electric power input	[ kW ]	0,8	0,8	0,83	0,83
SFPint	[ W/(m <sup>3</sup> /s) ]	776	776	784	784
Face velocity	[ m/s ]	1,25	1,25	1,43	1,43
Normal external pressure	[ Pa ]	250	250	250	250
Internal pressure drop of ventilation components	[ Pa ]	169/107	169/107	198/125	198/125
Static efficiency of fans used in accordance with Regulation No 327/2011	[ % ]	32,4	32,4	39,8	39,8
Declared maximum external leakage	[ % ]	<1	<1	<1	<1
Declared maximum internal leakage	[ % ]	<3	<3	<3	<3
Energy classification of the filters		E	E	E	E
Description of visual filter warning		Pressure control	Pressure control	Pressure control	Pressure control
Casing sound power level (Lwa)	[ dB(A) ]	57	57	58	58
ErP Compliance		2018	2018	2018	2018
Internet address for disassembly instructions		www.salda.lt			

<b>AMBERAIR COMPACT RIRS EKO 3.0</b>		<b>2500 VE</b>	<b>2500 VW</b>	<b>3500 VE</b>	<b>3500 VW</b>
Declared typology		Bidirectional	Bidirectional	Bidirectional	Bidirectional
Type of drive		Variable	Variable	Variable	Variable
Type of HRS		Regenerative	Regenerative	Regenerative	Regenerative
Thermal efficiency of heat recovery	[ % ]	74,8	74,8	73,9	73,9
Nominal NRVU flow rate	[ m <sup>3</sup> /s ]	0,66	0,66	0,89	0,89
Effective electric power input	[ kW ]	1,46	1,46	1,88	1,88
SFPint	[ W/(m <sup>3</sup> /s) ]	1025	1025	988	988
Face velocity	[ m/s ]	1,73	1,73	1,9	1,9
Normal external pressure	[ Pa ]	250	250	250	250
Internal pressure drop of ventilation components	[ Pa ]	237/191	237/191	242/198	242/198
Static efficiency of fans used in accordance with Regulation No 327/2011	[ % ]	40,2	40,2	42,8	42,8
Declared maximum external leakage	[ % ]	<1	<1	<1	<1
Declared maximum internal leakage	[ % ]	<3	<3	<3	<3
Energy classification of the filters		E	E	E	E
Description of visual filter warning		Pressure control	Pressure control	Pressure control	Pressure control
Casing sound power level (Lwa)	[ dB(A) ]	60	60	67	67
ErP Compliance		2018	2018	2018	2018
Internet address for disassembly instructions		www.salda.lt			

<b>AMBERAIR COMPACT RIRS EKO 3.0</b>		<b>5500 VE</b>	<b>5500 VW</b>
Declared typology		Bidirectional	Bidirectional
Type of drive		Variable	Variable
Type of HRS		Regenerative	Regenerative
Thermal efficiency of heat recovery	[ % ]	74,2	74,2
Nominal NRVU flow rate	[ m <sup>3</sup> /s ]	1,33	1,33
Effective electric power input	[ kW ]	2,59	2,59
SFPint	[ W/(m <sup>3</sup> /s) ]	936	936
Face velocity	[ m/s ]	1,9	1,9
Normal external pressure	[ Pa ]	250	250
Internal pressure drop of ventilation components	[ Pa ]	258/206	258/206
Static efficiency of fans used in accordance with Regulation No 327/2011	[ % ]	50,3	50,3
Declared maximum external leakage	[ % ]	<1	<1
Declared maximum internal leakage	[ % ]	<3	<3
Energy classification of the filters		E	E
Description of visual filter warning		Pressure control	Pressure control
Casing sound power level (Lwa)	[ dB(A) ]	69	69
ErP Compliance		2018	2018
Internet address for disassembly instructions		<a href="http://www.salda.it">www.salda.it</a>	

## 11. DECLARATION OF CONFORMITY

Manufacturer

**SALDA, UAB**  
**Ragainės g. 100**  
**LT-78109 Siauliai, Lithuania**  
**Tel.: +370 41 540415**  
**www.salda.lt**

Hereby confirms that the following products - Air handling units:

**AmberAir Compact RIRS \* EKO 3.0**

(where by „\*“ indicates possible unit installation type and modification)

Provided it was delivered and installed in the facility in accordance with the included installation instructions, comply with all applicable requirements in the following directives:

**Machinery Directive 2006/42/EC**  
**EMC Directive 2014/30/EU**  
**Low Voltage Directive 2014/35/EU**  
**Ecodesign Directive 2009/125/EC**  
**RoHS 2 Directive 2011/65/EU**

The following regulations are applied in applicable parts:

**Ecodesign requirements for ventilation units Nr. 1253/2014**  
**Energy labeling of residential units Nr. 1254/2014**

The following harmonized standards are applied in applicable parts:

LST EN 13141-7:2011 - Ventilation for buildings - Performance testing of components/products for residential ventilation - Part 7: Performance testing of a mechanical supply and exhaust ventilation units (including heat recovery) for mechanical ventilation systems intended for single family dwellings.

LST EN ISO 12100:2011 - Safety of machinery - General principles for design - Risk assessment and risk reduction.

LST EN 60204-1:2018 - Safety of machinery - Electrical equipment of machines - Part 1: General requirements.

LST EN 60335-1:2012 - Household and similar electrical appliances. Safety. Part 1: General requirements.

LST EN 60529:1999/A2:2014/AC:2019 - Degrees of protection provided by enclosures (IP code).

LST EN 61000-6-1:2007 - Electromagnetic compatibility (EMC) .Part 6-1: Generic standards - Immunity for residential, commercial and light-industrial environments.

LST EN 61000-6-4:2007/A11:2011 - Electromagnetic compatibility (EMC) .Part 6-4: Generic standards - Emission standard for industrial environments.

Should any alterations be made in the products, this declaration will no longer apply.

**Quality:** SALDA UAB activities are in line with the international quality management system standard **ISO 9001:2015**.

Date 2022-05-17



Giedrius Taujenis  
Product Manager

## 12. WARRANTY

1. All equipment manufactured in our factory is checked in operating conditions and tested before delivery. Test protocol is supplied together with the unit. The equipment is shipped in good working condition to the end-client. The unit is warranted for the period of two years from the invoice date.
2. If equipment is found to have been damaged during transportation, a claim should be made against carrier, as we assume no responsibility for such damage.
3. This warranty does not apply:
  - 3.1. when transportation, storage, installation and maintenance instructions of the unit are violated;
  - 3.2. when the equipment is improperly maintained, mounted - inadequate maintenance;
  - 3.3. when the equipment without our knowledge and permission has been upgraded or unskilled repairs were made;
  - 3.4. when the unit was used not for its original purpose.
  - 3.5. Company SALDA UAB is not responsible for potential loss of property or personal injury in cases where AHU is manufactured without a control system and the control system will be installed by the client or third parties. The manufacturer's warranty does not cover devices that will be damaged by installing the control system.
4. This warranty does not apply at these malfunction cases:
  - 4.1. mechanical damage;
  - 4.2. damage caused by entering outside objects, materials, liquids;
  - 4.3. damage caused by natural disaster, accident (voltage change in the electricity network, lightning, etc..).
5. The company assumes no liability for its products either directly or indirectly damage, if the damage is caused by failure to comply with installation and mounting regulations, deliberate or careless users or third-party behavior.

These conditions are readily discernable when the equipment is returned to our factory for inspection. If the direct client determines that equipment is found to be faulty, or a breakdown occurred, he should inform the manufacturer within five working days and deliver the equipment to manufacturer. Delivery costs should be covered by customer.



**Manufacturer reserves the right to change this technical passport any time without prior notice, if some typographic errors or inaccurate information is found, as well as after improving the apps and/or the devices. Such changes will be included in the new issues of the technical passport. All illustrations are just for information and thus may differ from the original device.**

### 12.1. LIMITED WARRANTY COUPON

Warranty term  
**24 months\***

I received complete package and technical manual of the product ready for usage. I have read warranty terms and conditions and agree with them:

.....  
 Customer's signature

\*refer to WARRANTY CONDITIONS

*Dear User, we appreciate your choice and do hereby guarantee that all ventilation equipment manufactured by our Company is inspected and thoroughly tested. An operational and high-quality product is sold to the direct buyer and shipped from the territory of the factory. It is provided with a 24-month warranty since invoice issue date. Your opinion is important to us, thus we always look forward to hearing your comments, feedback, or suggestions regarding technical and operational characteristics of the Products. In order to avoid any misunderstandings, please read the instructions for installation and operation of the product as well as other technical documents of the product carefully. The number of the Limited Warranty Coupon and serial number of the product specified on the silver identification sticker attached to the housing must match. The Limited Warranty Coupon shall be valid provided that the seller's stamps and records are clear. It is not allowed to change, delete, or rewrite the data specified on it in any manner – such a coupon shall be invalid. With this Limited Warranty Coupon the manufacturer confirms one's obligations to implement the imperative requirements established by effective laws on protection of consumer rights in the event of identification of any defects of the products. The manufacturer reserves the right to refuse provision of free warranty servicing in cases when the warranty conditions listed below are disregarded.*





## PRODUCT MAINTENANCE TABLE

Product name*		
SERIAL number*		
installation	interval	Date
Fan cleaning	Once per year**	_____
Heat-exchanger cleaning	Once per year**	_____
		_____
		_____
		_____
Filter replacement	Every 3-4 months**	_____
		_____
		_____
		_____
		_____

\* - Look at the product label.

\*\* - At least.

NOTE. The customer shall be required to complete the Product Maintenance Table.

## MANUALS IN OTHER LANGUAGES

DE



<https://select.salda.lt/file/aa-compact-rirs1200-5500v-eko-de>

DK



<https://select.salda.lt/file/aa-compact-rirs1200-5500v-eko-dk>

FR



<https://select.salda.lt/file/aa-compact-rirs1200-5500v-eko-fr>

LT



<https://select.salda.lt/file/aa-compact-rirs1200-5500v-eko-lt>

NL



<https://select.salda.lt/file/aa-compact-rirs1200-5500v-eko-nl>

PL



<https://select.salda.lt/file/aa-compact-rirs1200-5500v-eko-pl>

RU



<https://select.salda.lt/file/aa-compact-rirs1200-5500v-eko-ru>



MAN000406



Ragainės g. 100  
Šiauliai LT-78109, LITHUANIA

+370 41 540 415  
office@salda.lt