

Modification	Date	Name	Date	Appr.	Original	Replacement of	Replaced by		Power supply	Project Nr.	Offer nr.	= 2191943	Page 1 / 13
			2023-12-21	Jusadasbays		Control board for AHU							

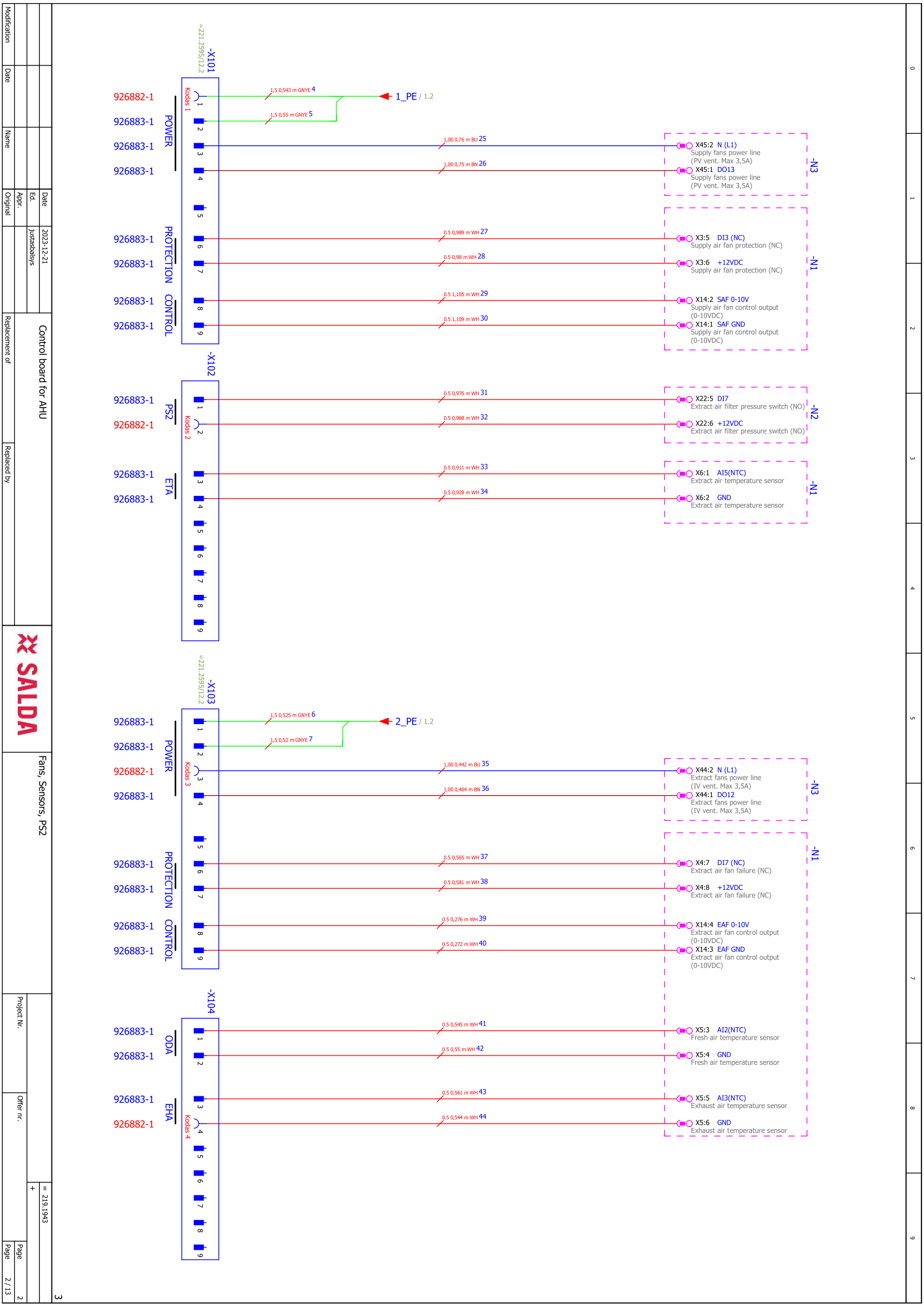

Modification	Date	Name	Date	Appr.	Original	Replacement of	Replaced by
			2023-12-21	justadobers		Control board for AHU	

Project No. Offer nr. = 2191943

Fans, Sensors, PSZ

Page 2 / 13

3

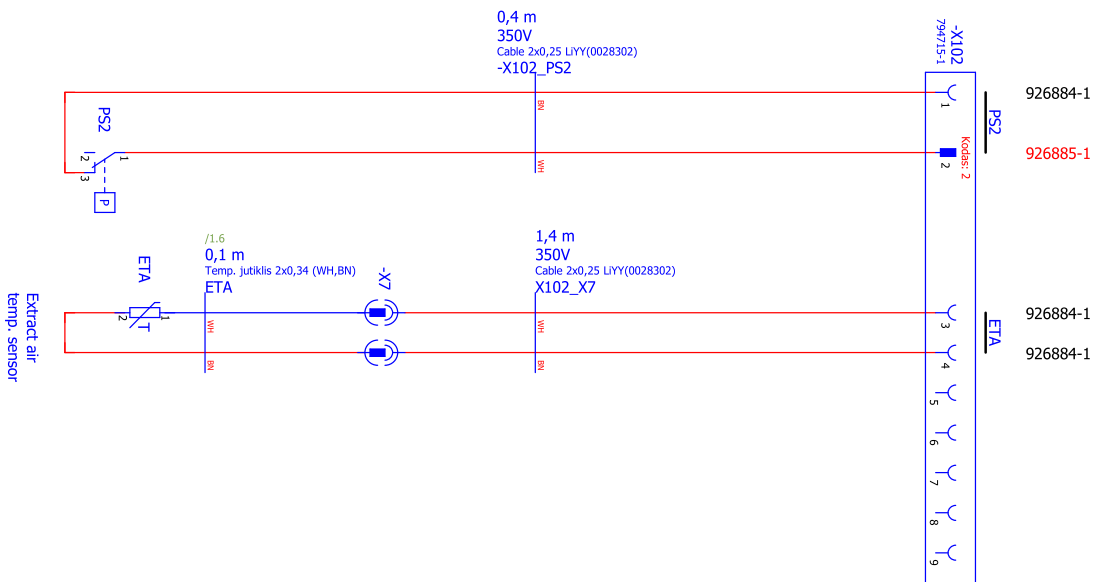
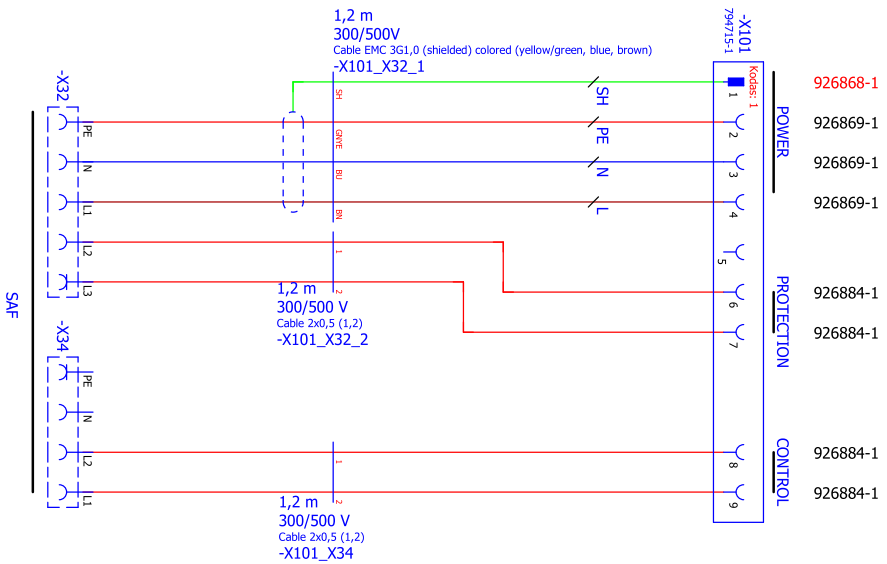

Modification	Date	Name	Date	2023-12-20	Juradebišys	Harness for AHU	Replacement of	Replaced by	221.2556.1-PS	Project Nr.	Offer nr.	= 221.2596
			Edt.									
			Apr.									Page
			Original									Page
												1 / 9

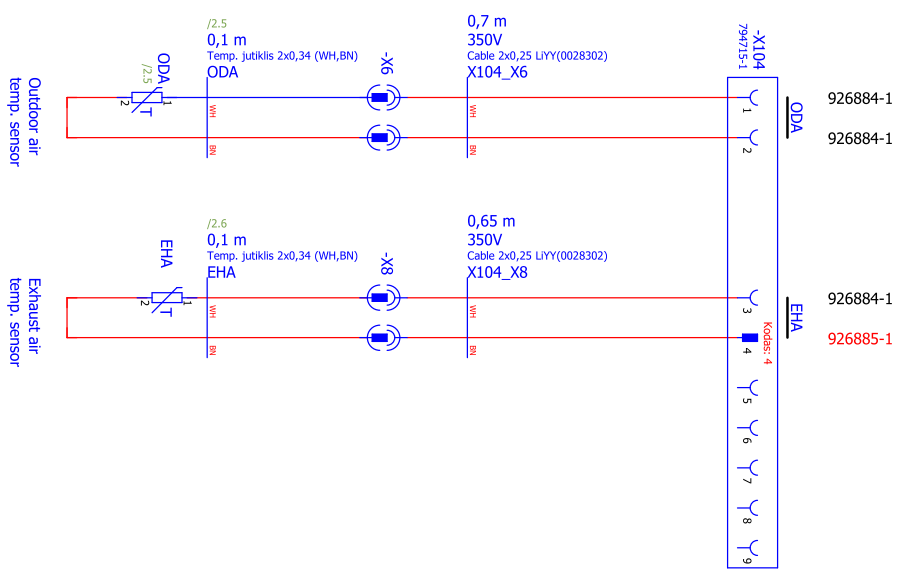
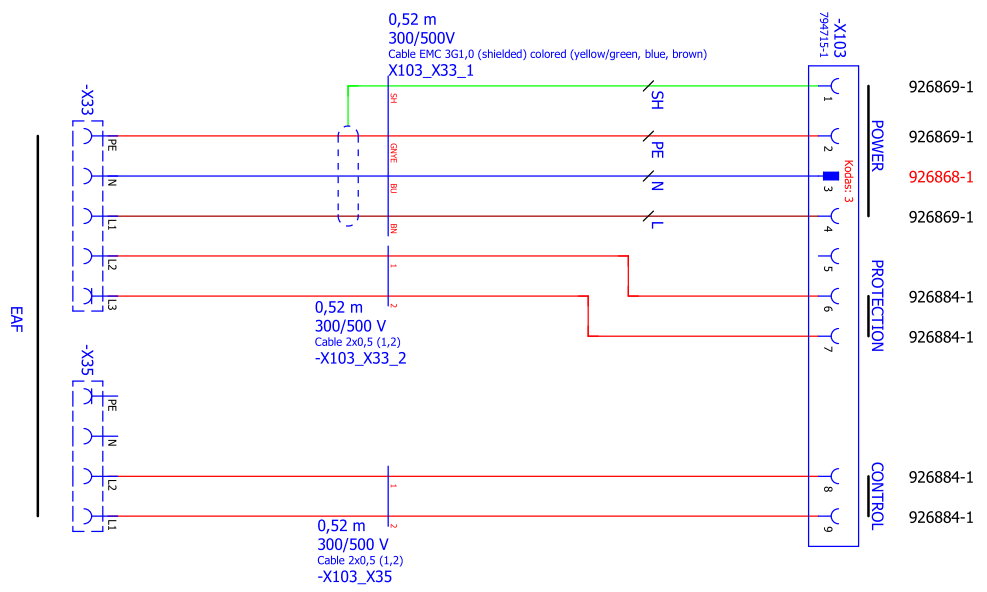

Modification		Date	Name	Date	2023-12-20	Harness for AHU		Project Nr.	221.2556.2-PS	Offer nr.	= 221.2596
		Ed.	Juradebišys	Apr.		Replacement of					+
		Original				Replaced by					Page
											Page
											2 / 9



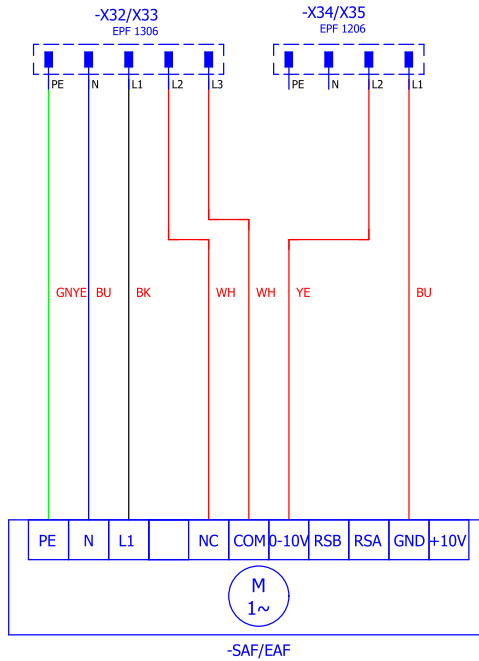

			Date	2023-03-08
			Ed.	justasbalsys
			Appr.	
Modification	Date	Name	Original	

Replacement of	Replaced by
----------------	-------------



Fans

		= SP148 (EBM fan)	
		+	
Project Nr.	Offer nr.	Page	1
		Page	1 / 1

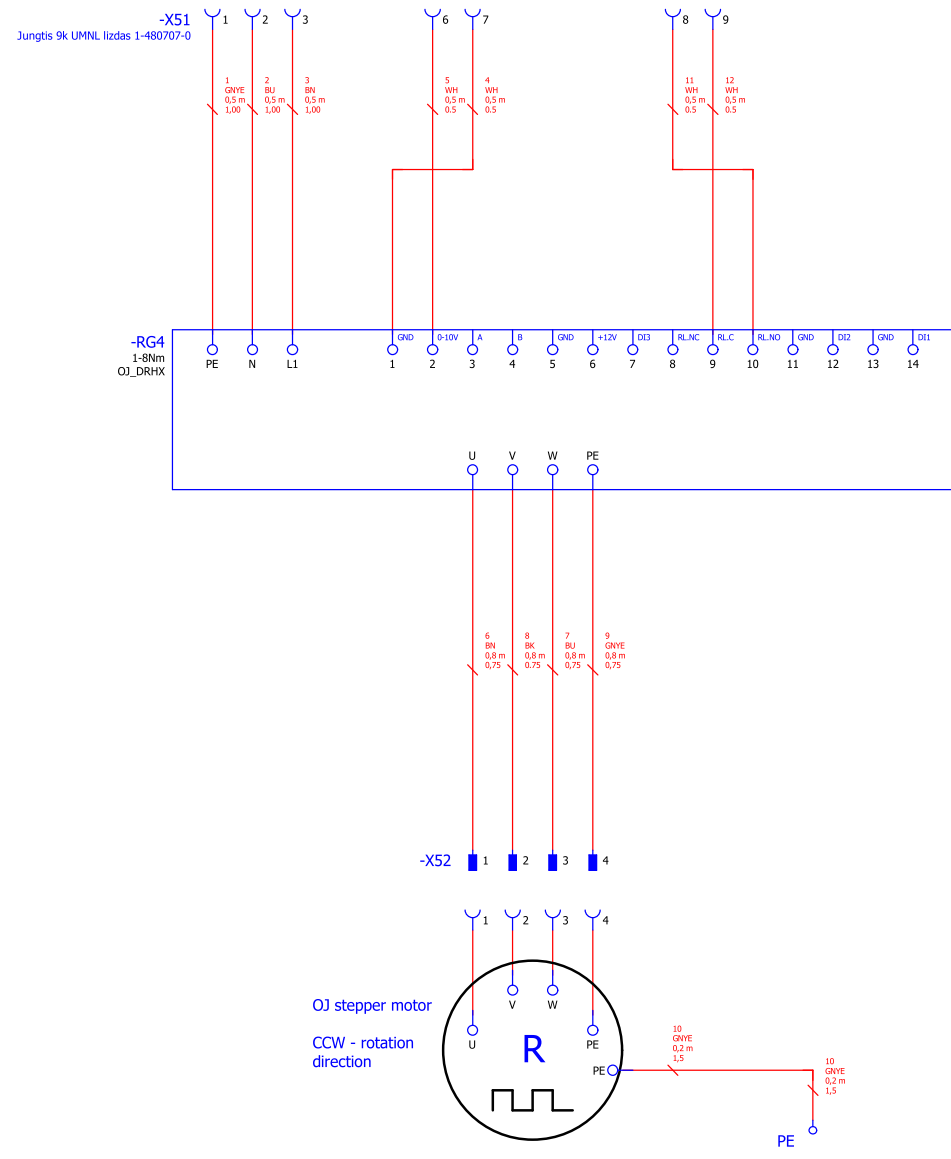

			Date	2023-10-24		221.2189.1-PS			= 221.2189	
			Ed.	justasbalsys					+	
			Appr.				Project Nr.	Offer nr.	Page	1
Modification	Date	Name	Original		Replacement of	Replaced by			Page 1 / 3	

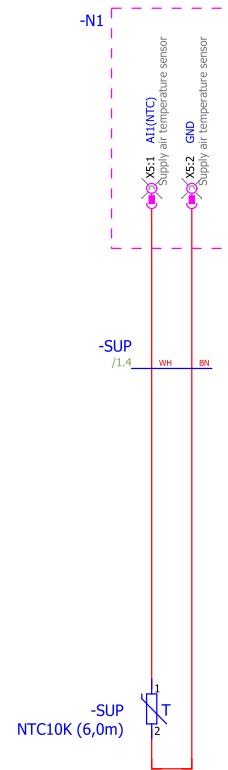

			Date	2023-01-20
			Ed.	justasbalsys
			Appr.	
Modification	Date	Name	Original	

Replacement of	Replaced by
----------------	-------------



SUP to MCB

		= SP150 (SUP connection to MCB)
		+
Project Nr.	Offer nr.	Page 1
		Page 1 / 1