

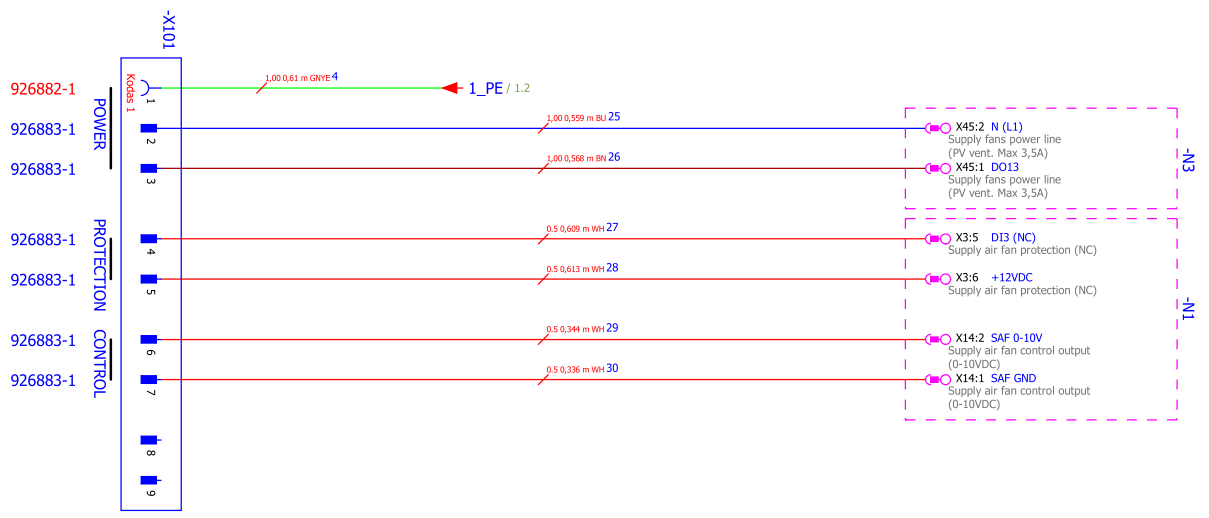

Modification	Date	Name	Date	Ed.	Apr.	Original	Replacement of	Replaced by
			2024-07-03	justasablys			Control board for AHU	
			Fans, Sensors, PS					
			Project Nr.	Offer nr.	= 219.2053			
			Page	2		Page 2 / 12		

SAF



EAF

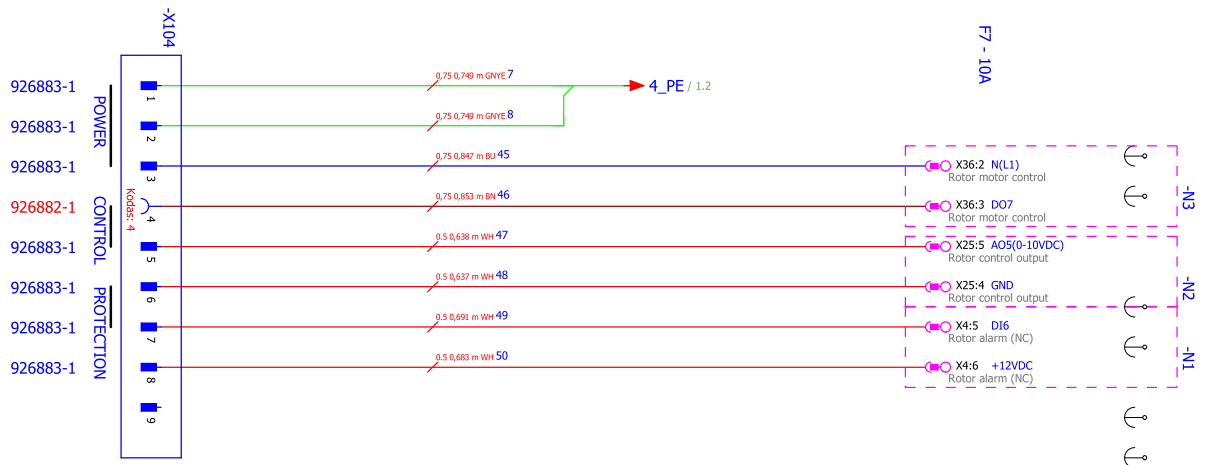
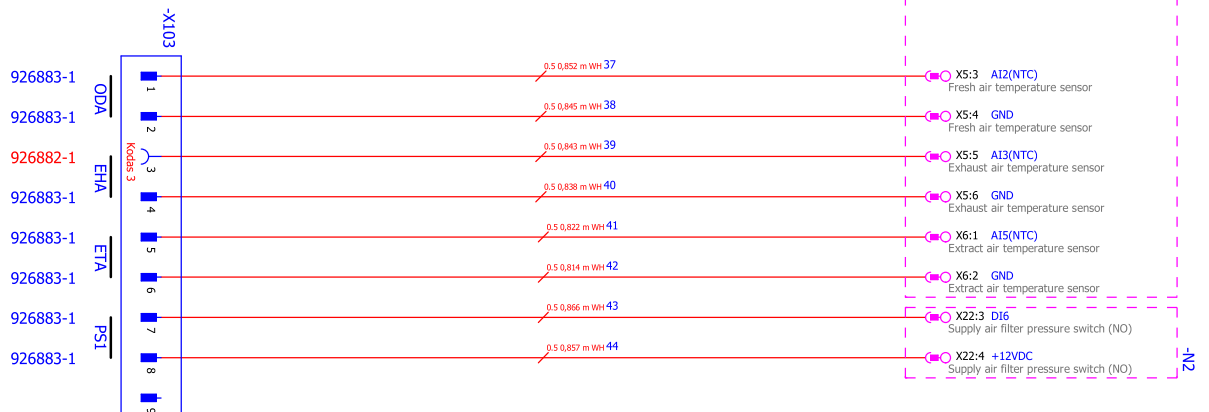
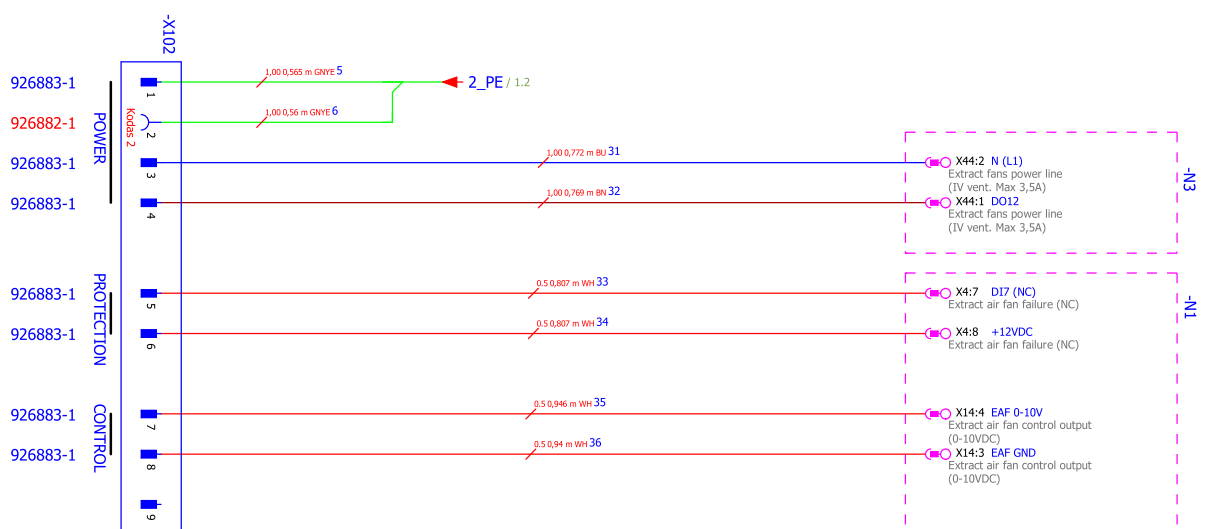

Modification	Date	Name	Date	Original	Replacement of	Replaced by
			2024-07-03	Ed. justasabals	Control board for AHU	



PSZ wires, Communication

Project Nr.	Offer nr.	+ 219.2053
		Page 3 / 12

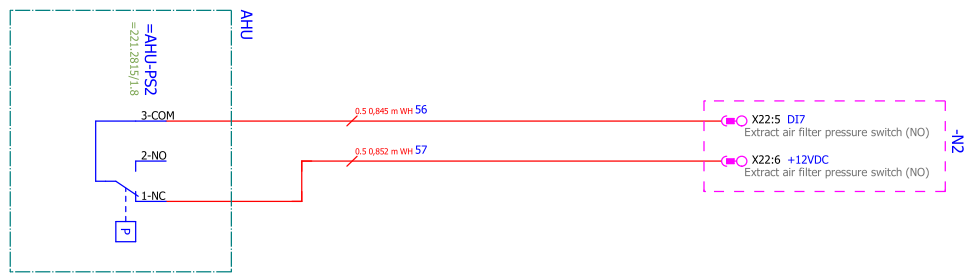
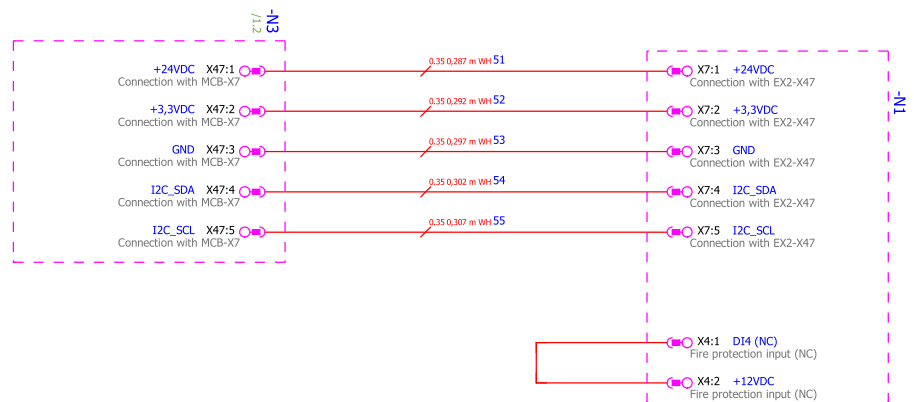

Jungtis 9k UMNL Izzdas su sijonu 794715-1

-X101

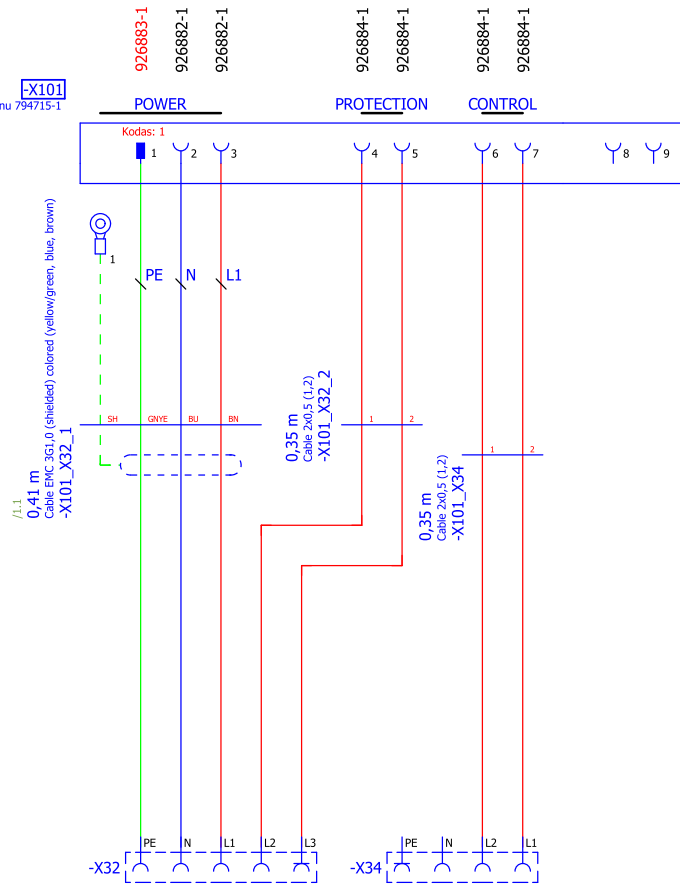

SAF

Jungtis 9k UMNL Izzdas su sijonu 794715-1

-X102

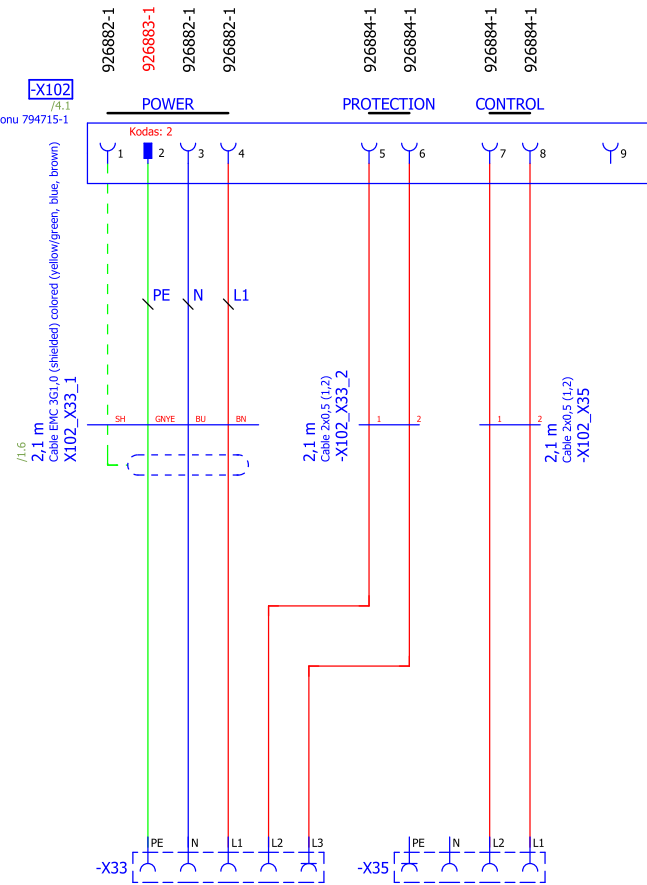

EAF

Modification	Date	Name	Original	Replacement of	Replaced by
	2024-07-03		justasbalys		



221.2816.1-PS

Project Nr.		Offer nr.		Page
				1
				Page
				1 / 10

= 221.2816

+

Jungtis 9K UMNL, lizdas su sijaun 79/77/55-1

- 926884-1
- 926884-1
- 926885-1
- 926884-1
- 926884-1
- 926884-1
- 926884-1

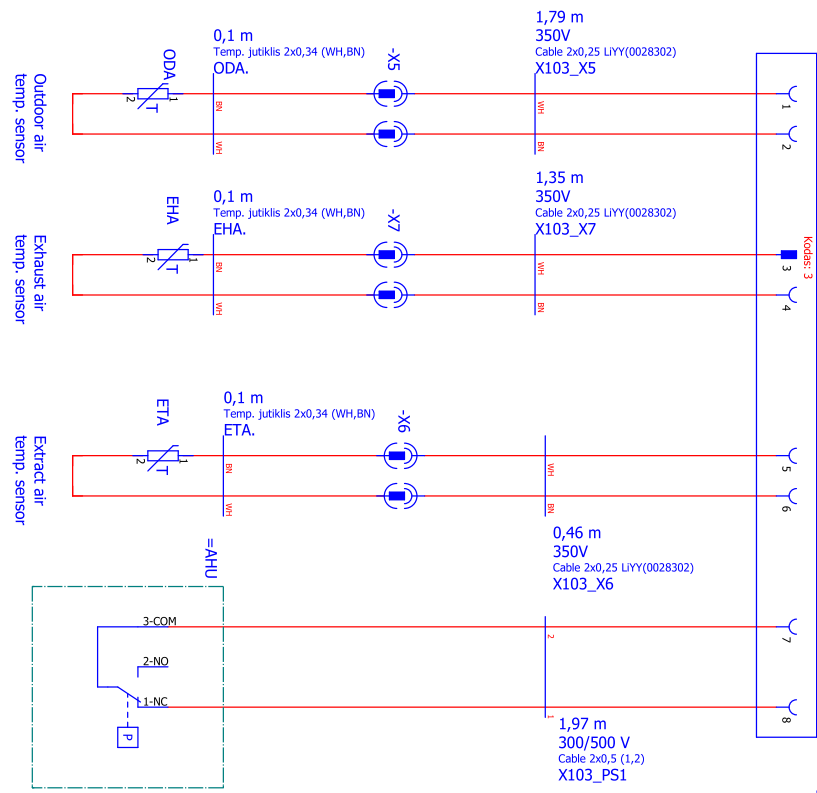

Jungtis 9K UMNL, lizdas su sijaun 79/77/55-1

- 926882-1
- 926882-1
- 926882-1
- 926883-1
- 926884-1
- 926884-1
- 926884-1
- 926884-1
- 926884-1

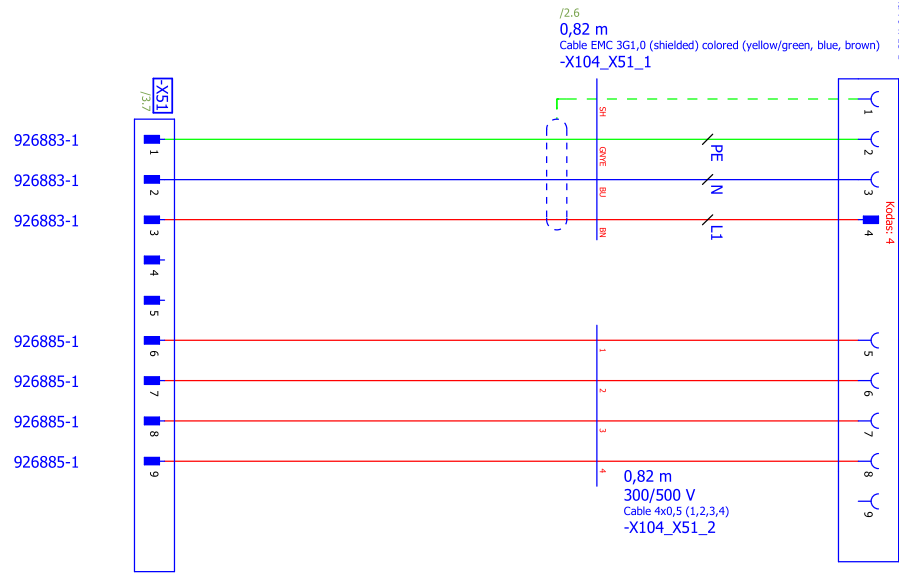

Modification	Date	Name	Original	Replacement of	Replaced by
	2024-07-03				
Ed.	justasabals				
Project Nr.	Z21.2816.2.PS				
Offer nr.					
Page	= Z21.2816				
Page	2				
Page	2 / 10				



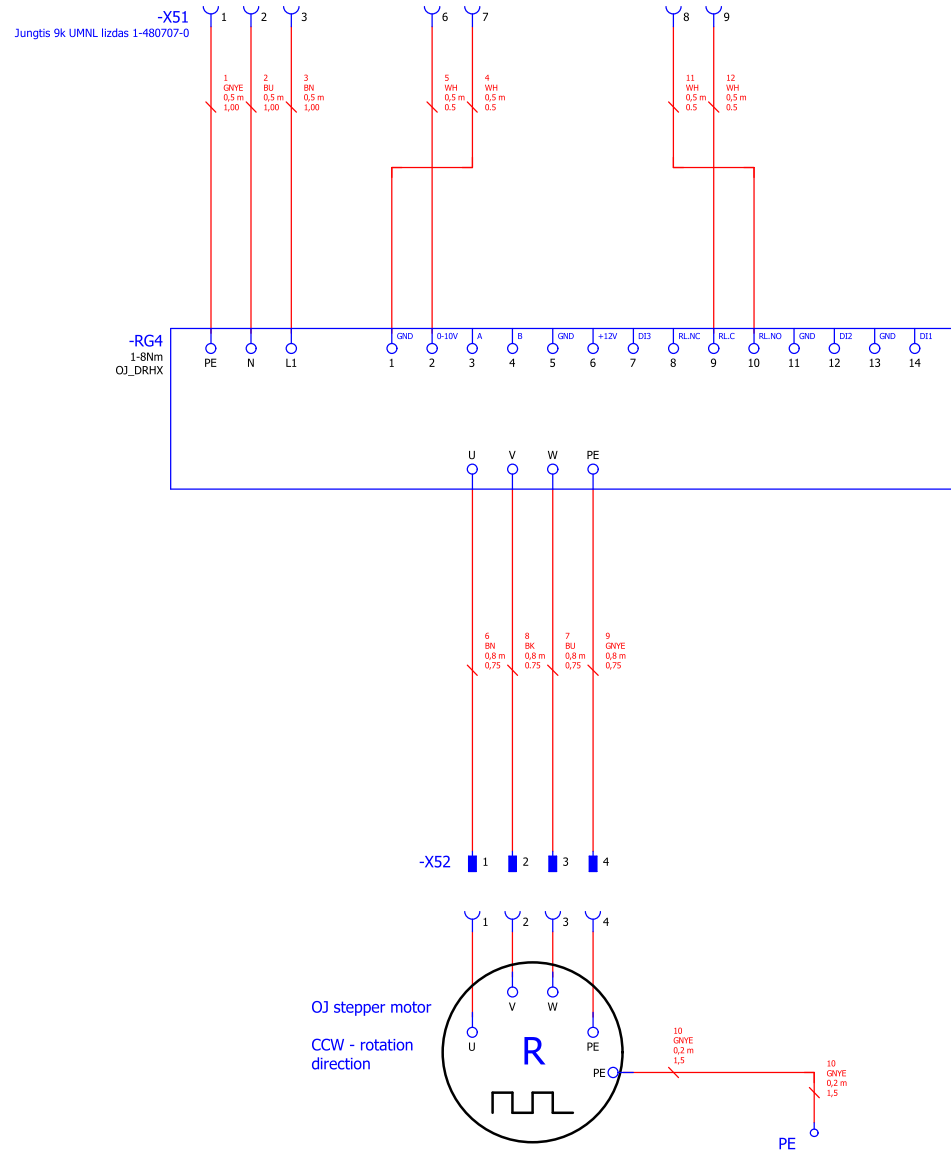

			Date	2023-10-24	<b>SALDA</b>	221.2189.1-PS	= 221.2189	
			Ed.	justasbalys			+	
			Appr.				Project Nr.	Offer nr.
Modification	Date	Name	Original		Replacement of	Replaced by		Page 1 / 3

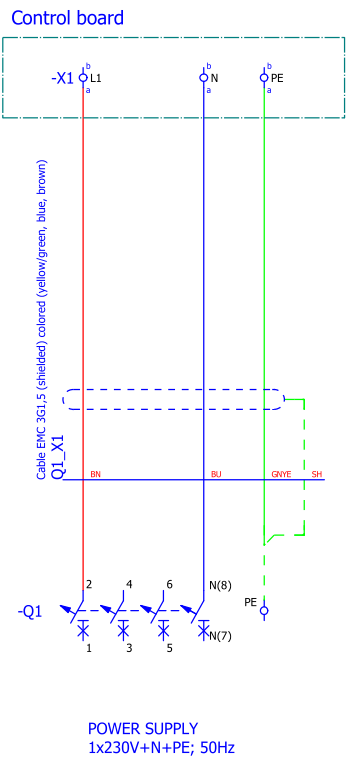

			Date	2023-12-06	SP152		AAC S-R 1000/1500 V main switch connection (1f)	=	+
			Ed.	justasbalsys					
			Appr.						
Modification	Date	Name	Original		Replacement of	Replaced by	Project Nr.	Offer nr.	Page SP152 Page 1 / 1

Control board

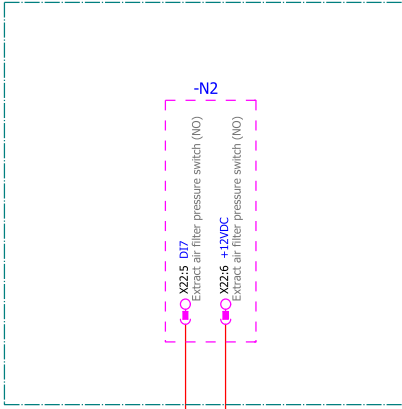

NOTE: Wires comes from the control board

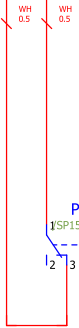

PS600

Control board

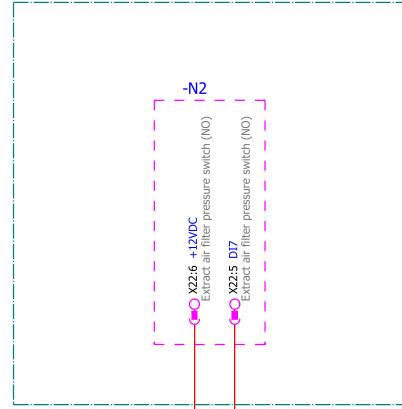

NOTE: Wires comes from the control board

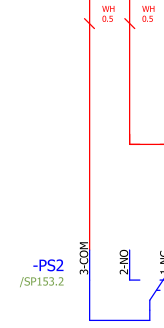

DPR500

			Date	2023-12-07	SP153	
			Ed.	Vidas.Petraitis		
			Appr.			
Modification	Date	Name	Original		Replacement of	Replaced by



AAC S-R V MCB PS2 connection

			=
			+
Project Nr.	Offer nr.	Page	SP153
		Page	1 / 1



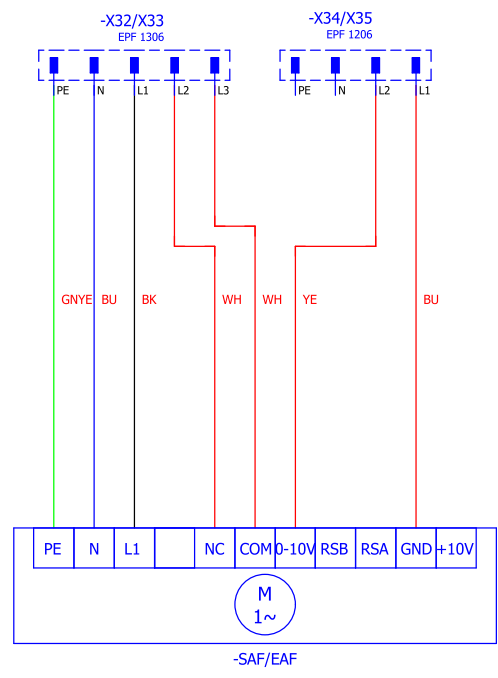

			Date	2023-03-08
			Ed.	justasbalys
			Appr.	
Modification	Date	Name	Original	
			Replacement of	Replaced by



Fans	

		= SP148 (EBM fan)
		+
Project Nr.	Offer nr.	Page 1 / 1

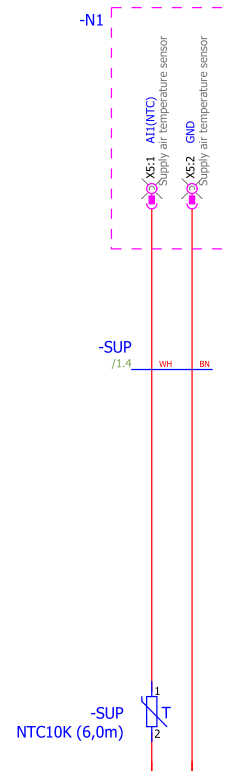

			Date	2023-01-20		
			Ed.	justasbalys		
			Appr.			
Modification	Date	Name	Original	Replacement of	Replaced by	



SUP to MCB

		= SP150 (SUP connection to MCB)	
		+	
Project Nr.	Offer nr.	Page	1
		Page	1 / 1

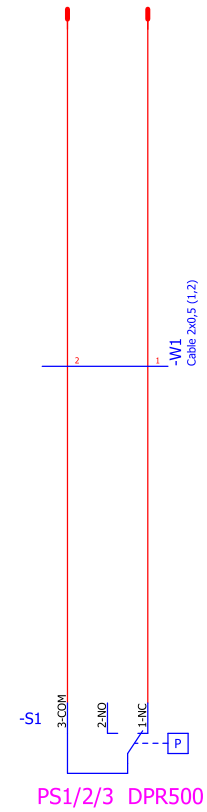
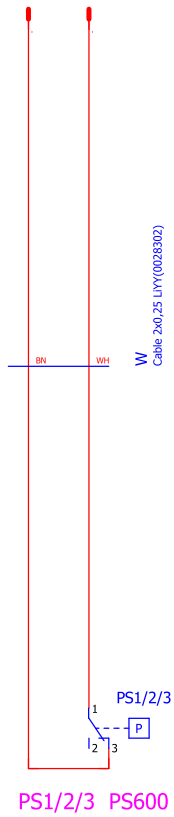

			Date	2023-12-05	SP158	
			Ed.	Vidas.Petraitis		
			Appr.			
Modification	Date	Name	Original		Replacement of	Replaced by



PS1/2/3 connection to harness (MCB)

			=
			+
Project Nr.	Offer nr.	Page	SP158
		Page	1 / 1