

Modification		Date	Date	Control board for AHU		Power supply	Project Nr.	Offer nr.	= 2191.1822	Page 1 / 12
	Date			Replacement of	Released by					
			2023-11-30							
			Jusadashvys							

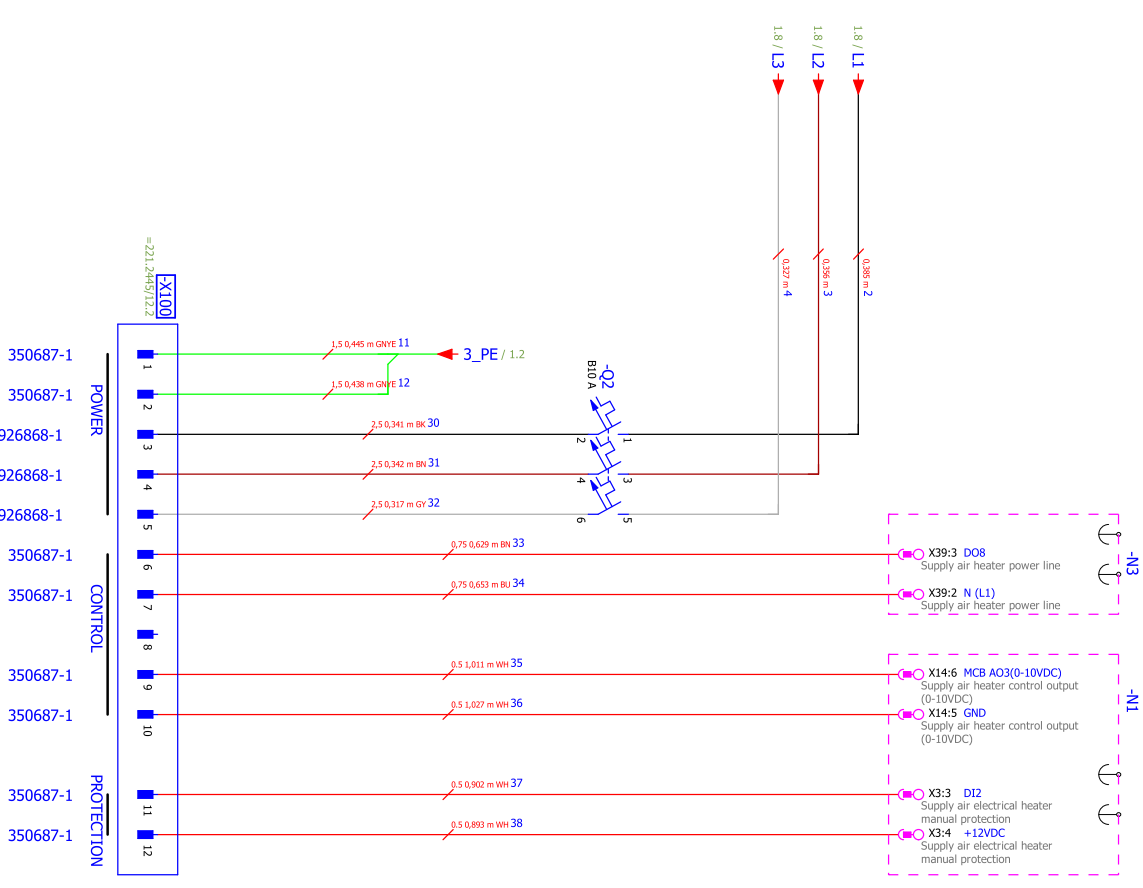

Modification	Date	Name	Date	Original	Replaced by	Replaced by
	2023-11-30	Jusadaibovs			Control board for AHU	Heater



Project Nr.	Offer nr.	= 219,1822
		+
Page	Page	2 / 12

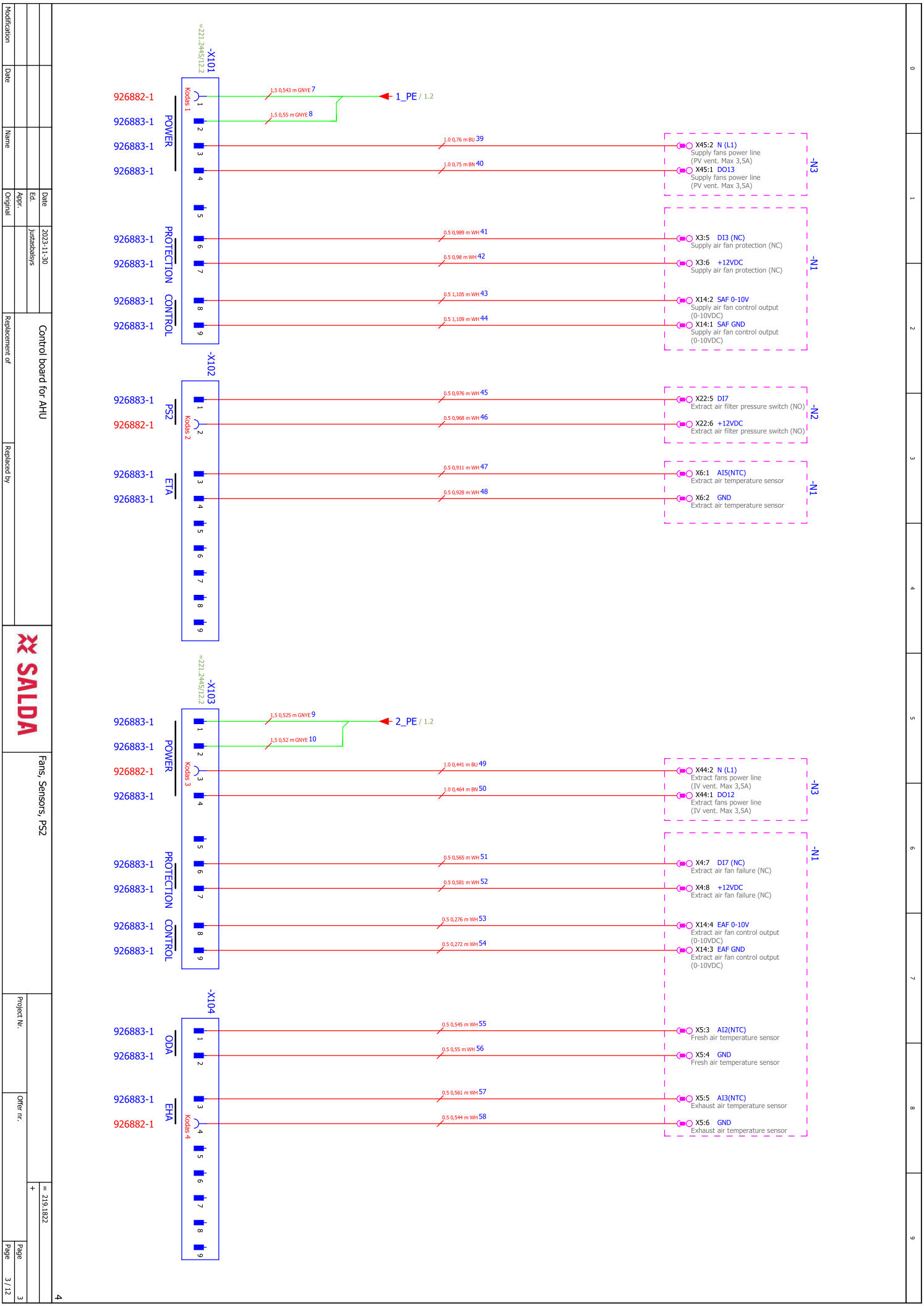

Modification	Date	Name

Date	2023-11-30
Edt.	Jusekshisys
Appt.	
Original	

Control board for AHU
 Replacement of
 Replaced by



Fans, Sensors, PSZ

Project Nr.	
Offer nr.	
Page	3 / 12

= 21913822

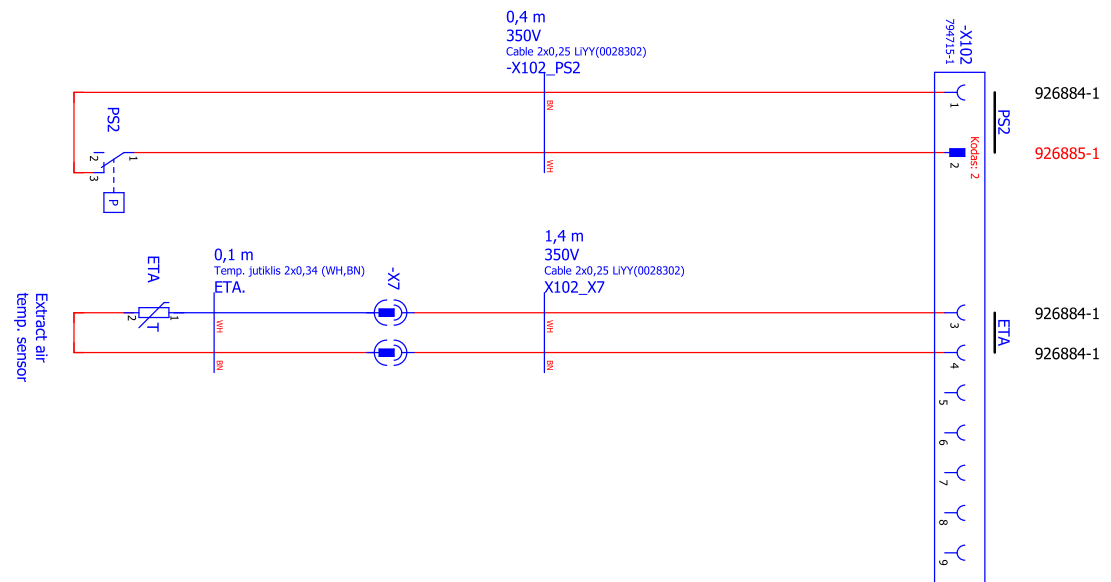
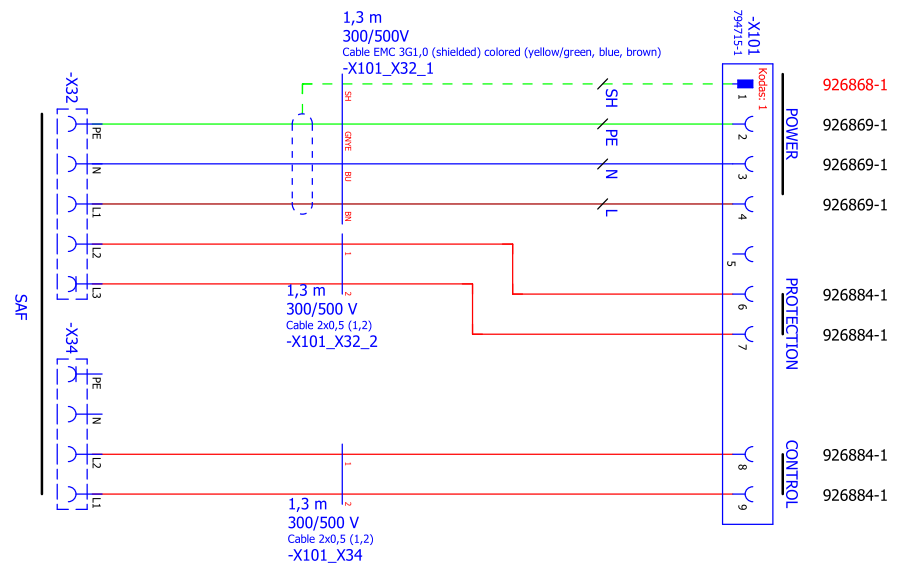

Modification	Date	2023-03-21
Ed.	Appr.	Juhatshaps
Date	Name	
Original	Appr.	
Replacement of	Replaced by	
SALDA		
221.2446.1-PS		
Project Nr.	Offer nr.	
= 221.2446		
Page	Page	1
Page	Page	1 / 10

0	1	2	3	4	5	6	7	8	9
2023-05-04	2023-05-04	2023-05-04	2023-05-04	2023-05-04	2023-05-04	2023-05-04	2023-05-04	2023-05-04	2023-05-04
Ed.	Ed.	Ed.	Ed.	Ed.	Ed.	Ed.	Ed.	Ed.	Ed.
Justaševičius	Justaševičius	Justaševičius	Justaševičius	Justaševičius	Justaševičius	Justaševičius	Justaševičius	Justaševičius	Justaševičius
Original	Original	Original	Original	Original	Original	Original	Original	Original	Original
Replacement of	Replacement of	Replacement of	Replacement of	Replacement of	Replacement of	Replacement of	Replacement of	Replacement of	Replacement of
Replaced by	Replaced by	Replaced by	Replaced by	Replaced by	Replaced by	Replaced by	Replaced by	Replaced by	Replaced by
SALDA									
221.2446.2-PS									
Project Nr.									
Offer nr.									
= 221.2446									
Page									
Page									
2 / 10									

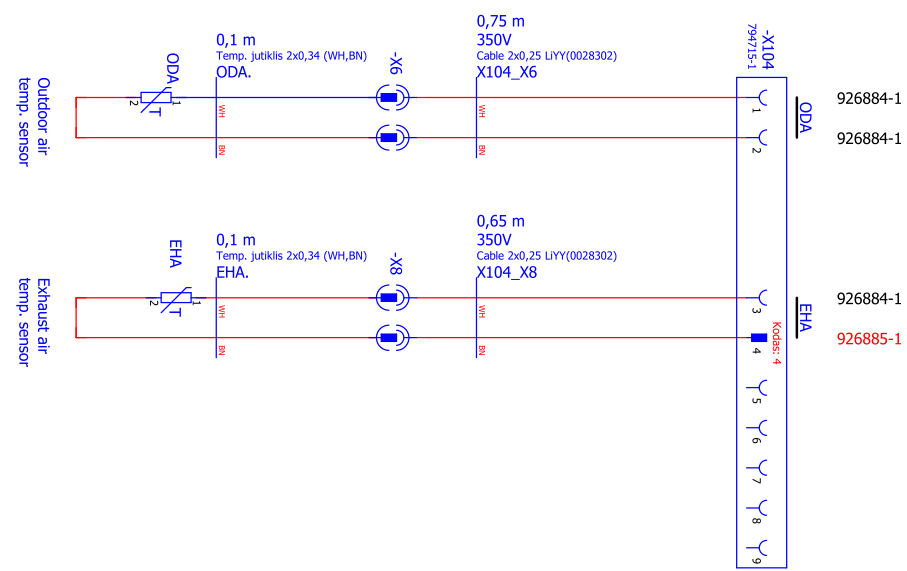
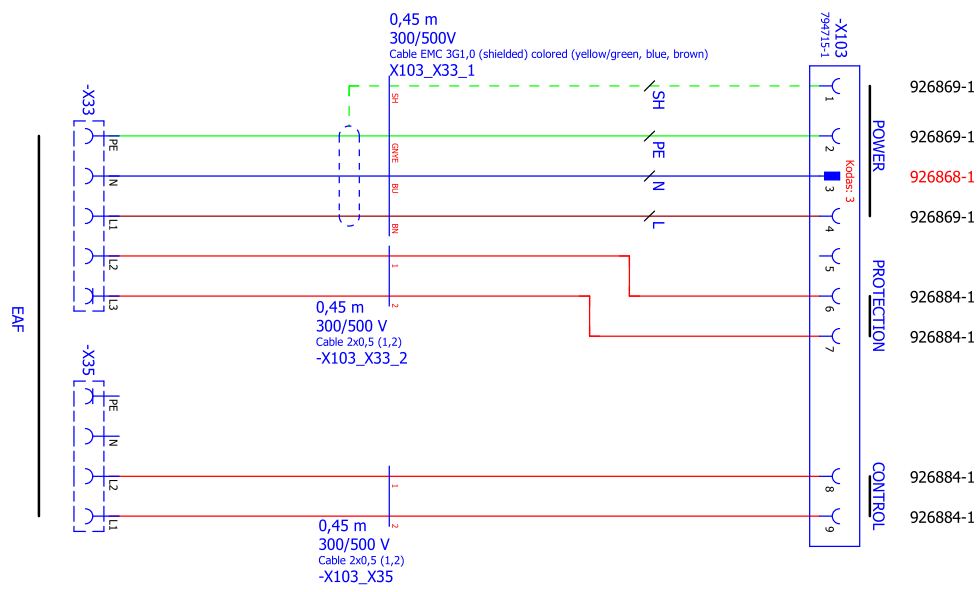

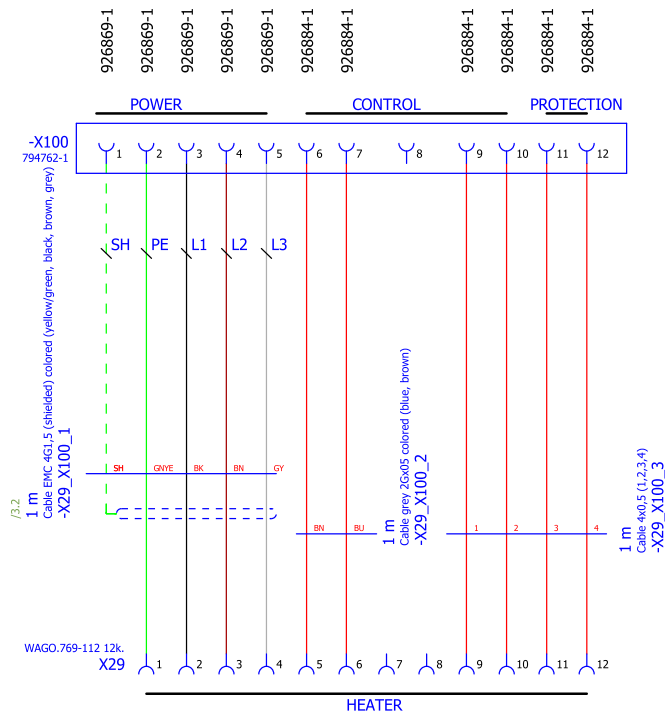

926869-1
926869-1
926869-1
926869-1
926869-1
926884-1
926884-1

926884-1
926884-1
926884-1
926884-1

POWER CONTROL PROTECTION

-X100
794762-1

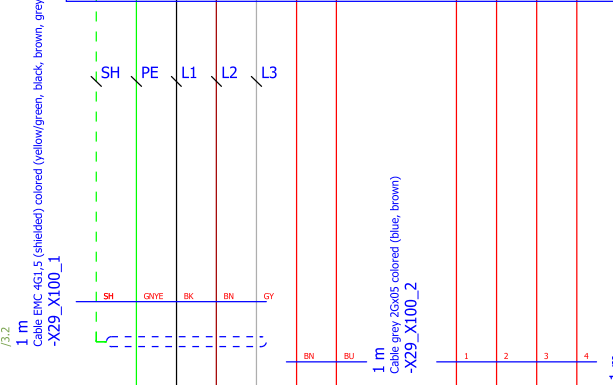

WAGO.769-112 12k.
X29

HEATER

			Date	2023-02-28		221.2446.3-PS			= 221.2446	
			Ed.	justasbalsys					+	
			Appr.							Page
Modification	Date	Name	Original		Replacement of	Replaced by	Project Nr.	Offer nr.	Page	3 / 10

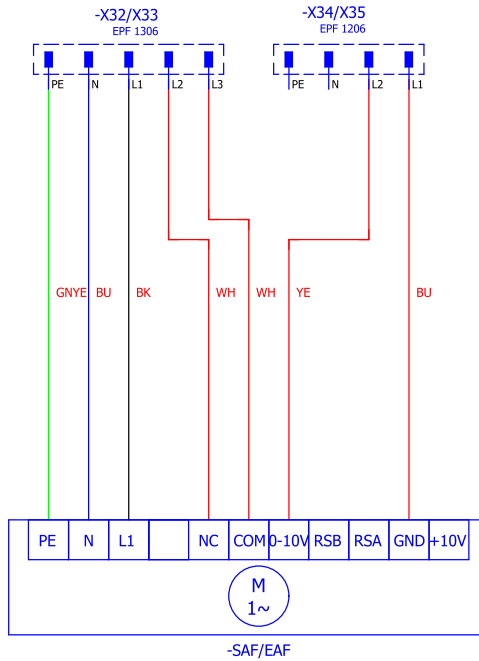

			Date	2023-03-08
			Ed.	justasbalsys
			Appr.	
Modification	Date	Name	Original	

Replacement of	Replaced by
----------------	-------------



Fans

		= SP148 (EBM fan)	
		+	
Project Nr.	Offer nr.	Page	1
		Page	1 / 1

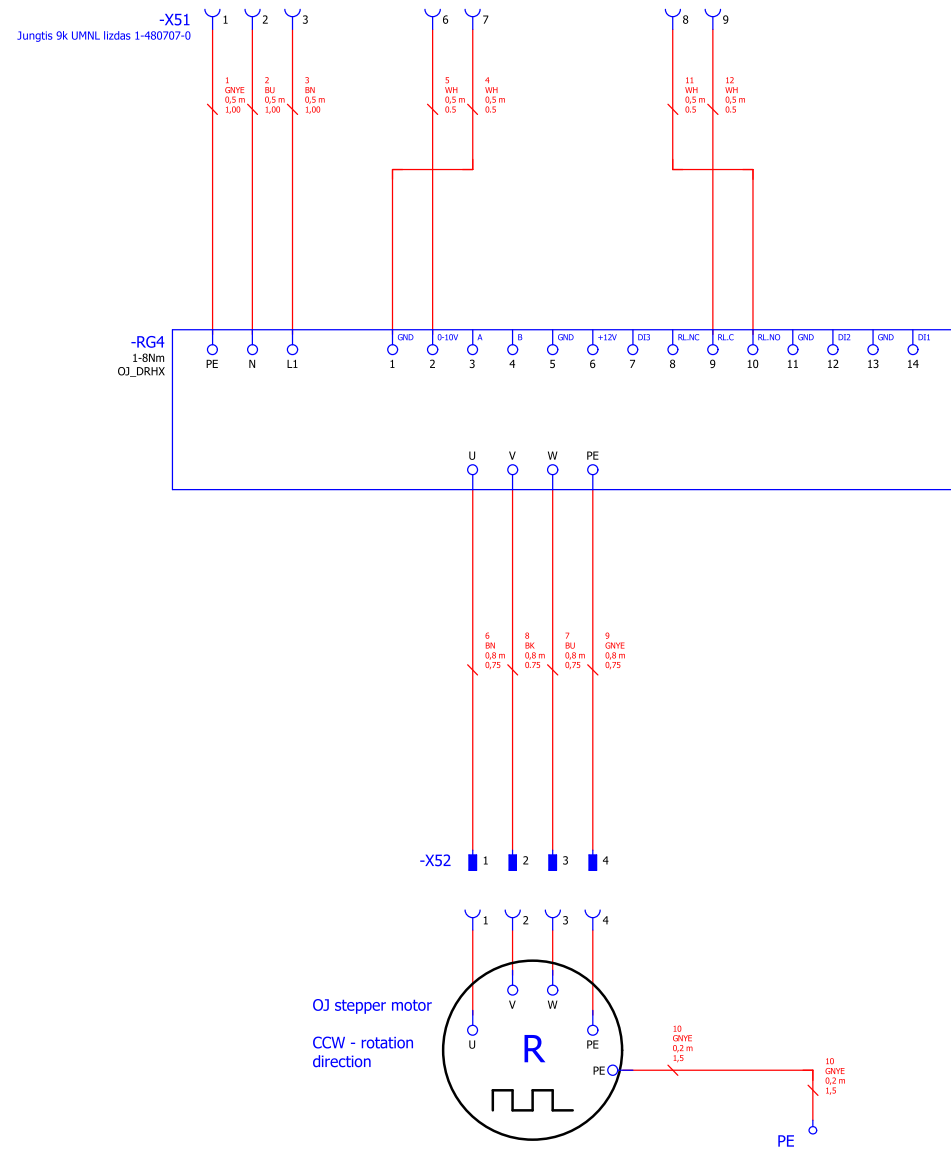

			Date	2023-10-24	SALDA	221.2189.1-PS			= 221.2189	
			Ed.	justasbalsys					+	
			Appr.				Project Nr.	Offer nr.	Page	1
Modification	Date	Name	Original		Replacement of	Replaced by		Page	1 / 3	

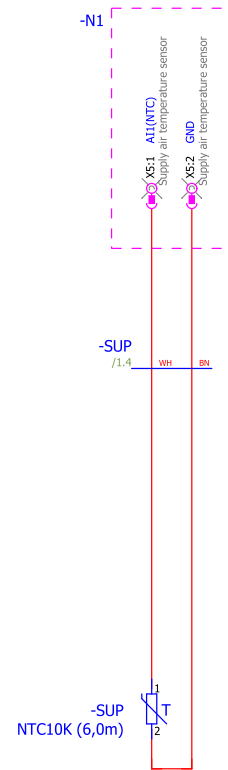

			Date	2023-01-20
			Ed.	justasbalsys
			Appr.	
Modification	Date	Name	Original	

Replacement of	Replaced by
----------------	-------------



SUP to MCB

		= SP150 (SUP connection to MCB)
		+
Project Nr.	Offer nr.	Page 1
		Page 1 / 1