

Modification		Date	
Date		2024-02-26	
Name		mindaugasbelckas	
Appr.			
Original			
Replacement of	Control board for AHU		
Replaced by			
SALDA			
Project Nr.	= 219.1990		
Offer nr.			
Page	1		
Page	1 / 11		

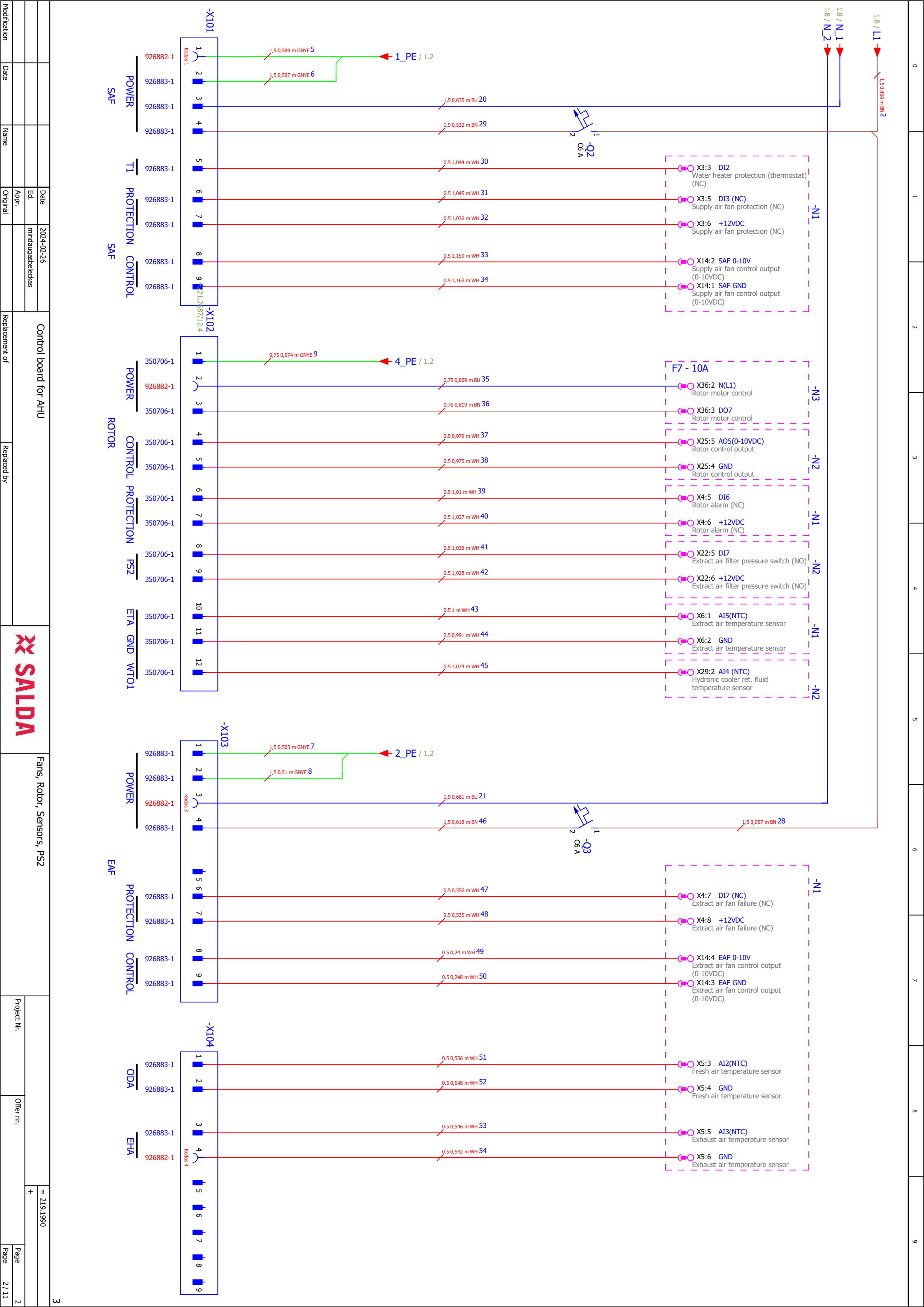

Control board for AHU

Fans, Rotor, Sensors, PS2

Project Nr.

Offer nr.

= 219.1990

Page 2 / 11

3

Modification		Date	
Date		Ed.	
Name		Appr.	
Original			
Replacement of		Date	
Replaced by		mindaugasbelekias	
Control board for AHU		2024-02-26	

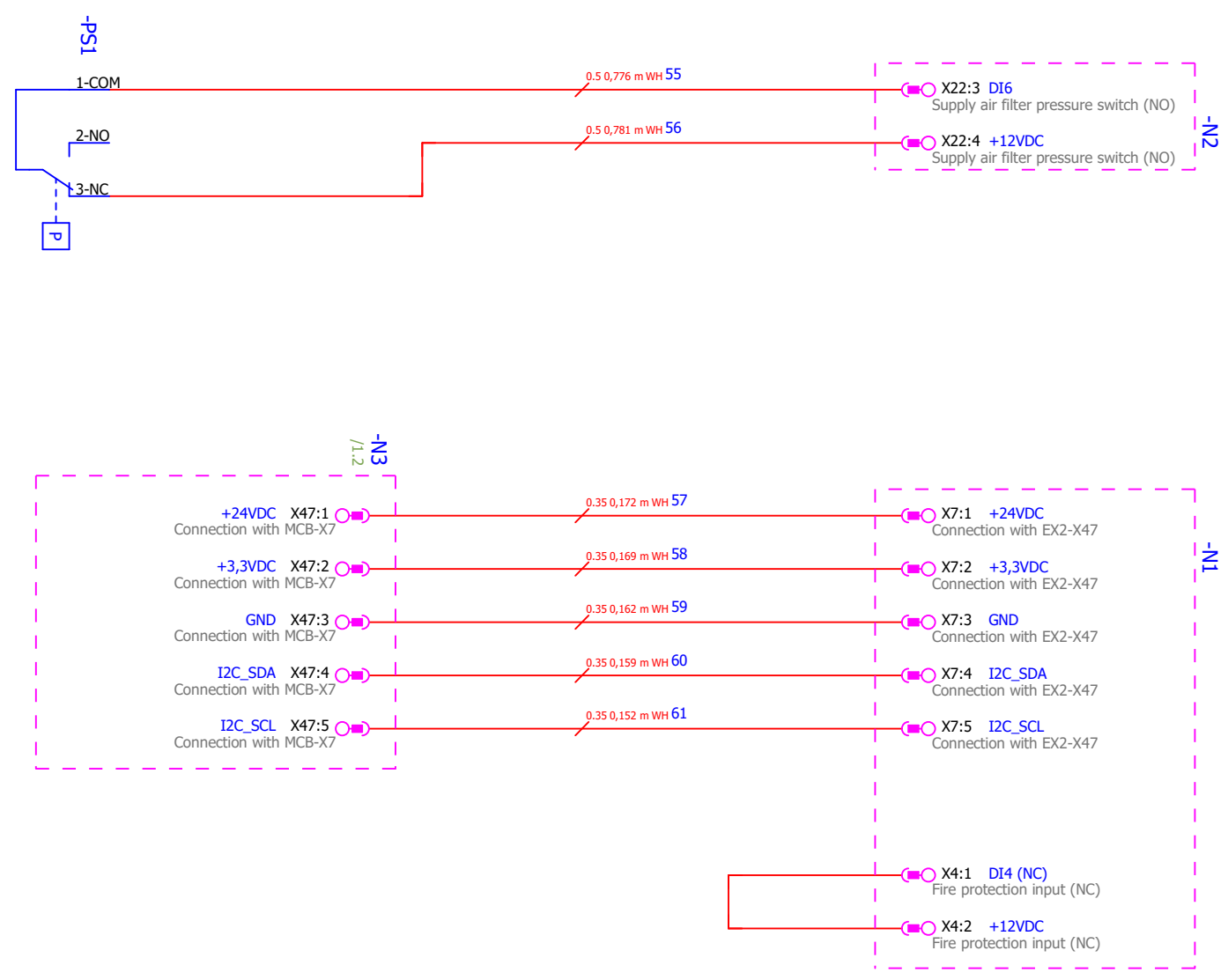

PS1, Communication

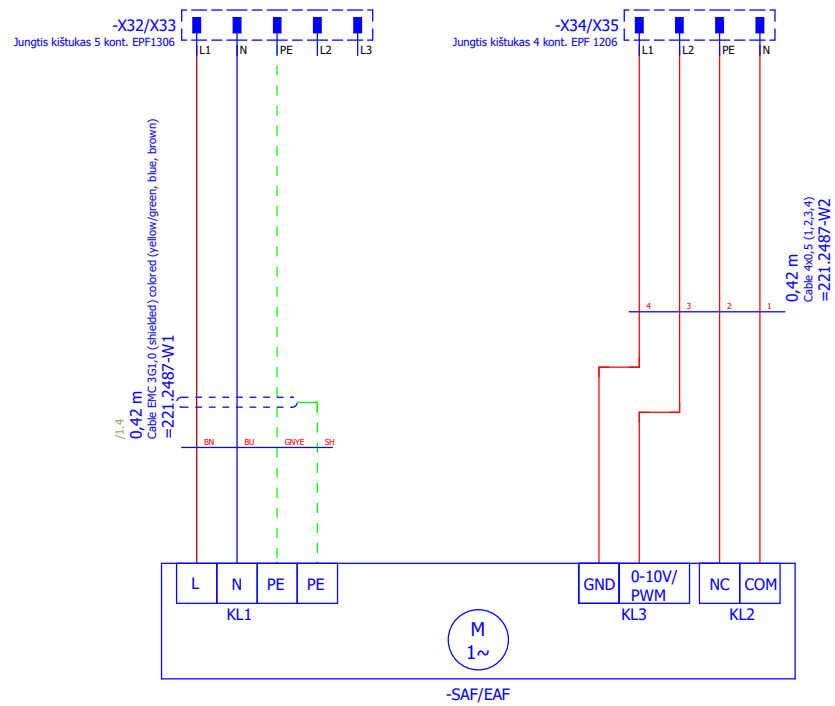

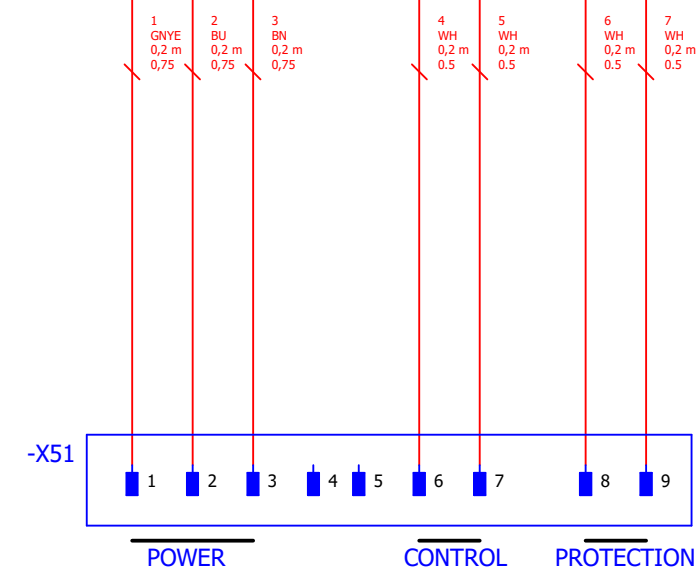
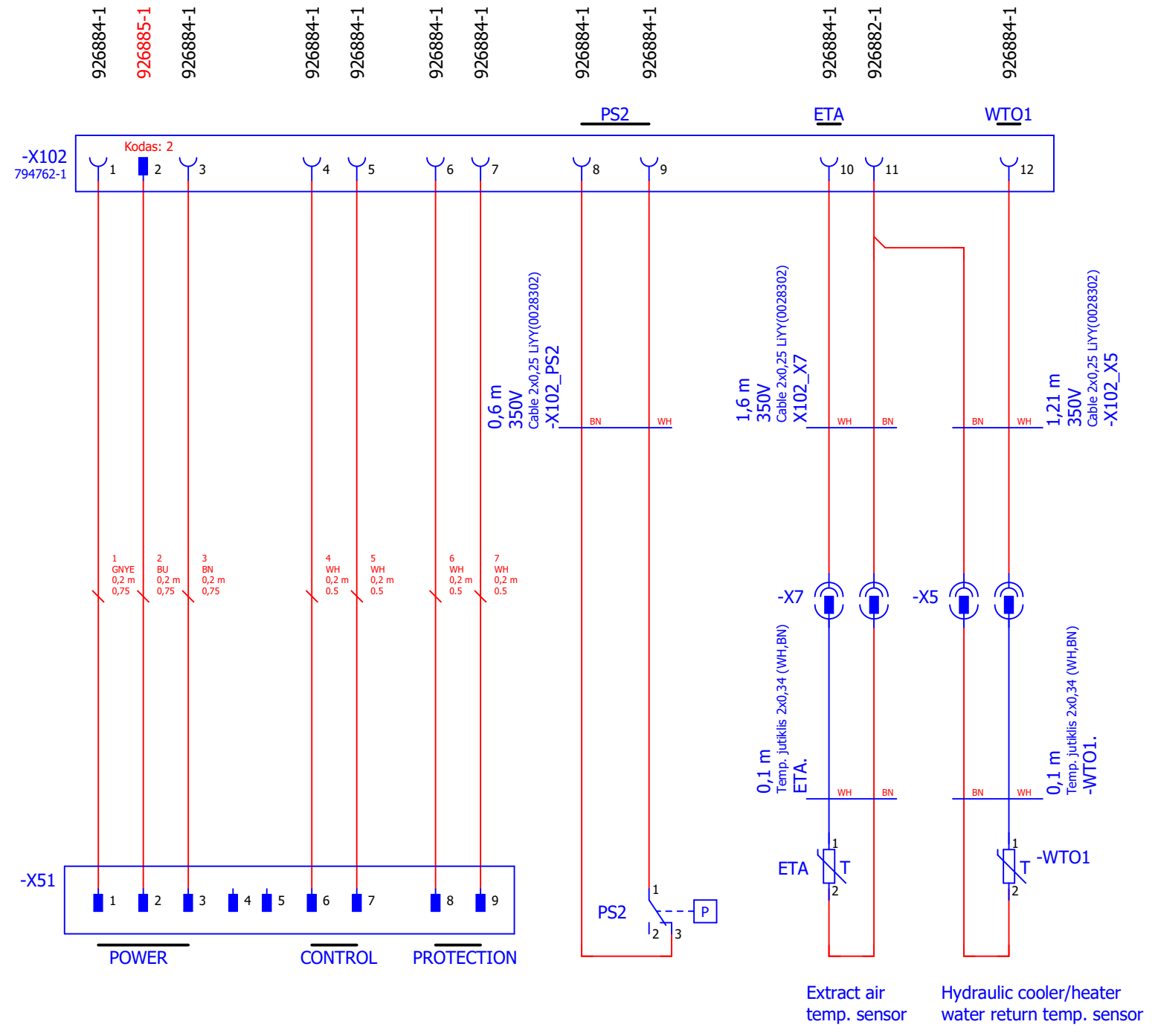
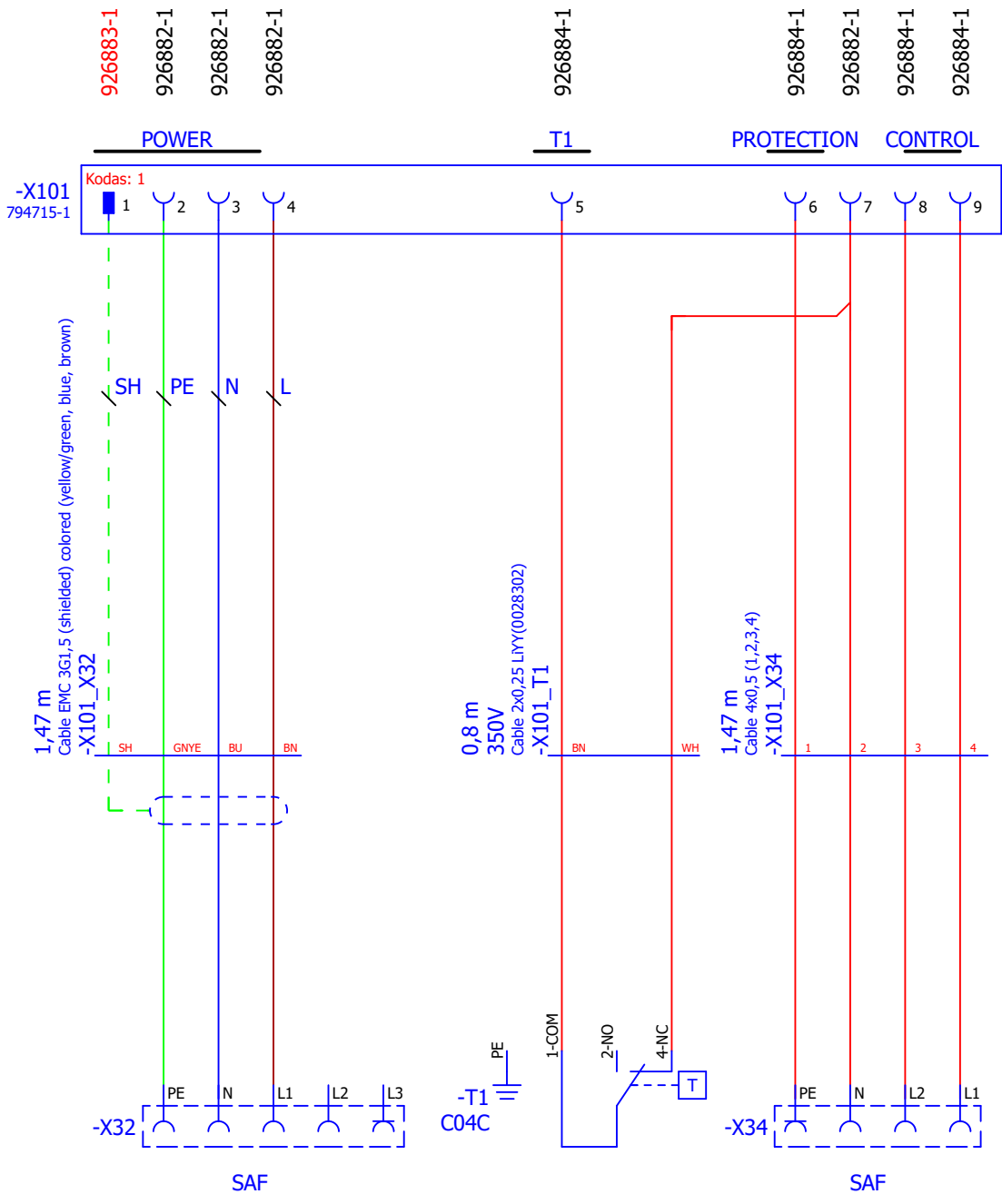

Modification	Date	Name	Original	Replacement of	Replaced by

Date	2024-02-26
Ed.	mindaugasbeleckas
Appr.	
Harness for AHU	



221.2659.1-PS

= 221.2659	
Project Nr.	Offer nr.
Page 1	Page 1 / 10

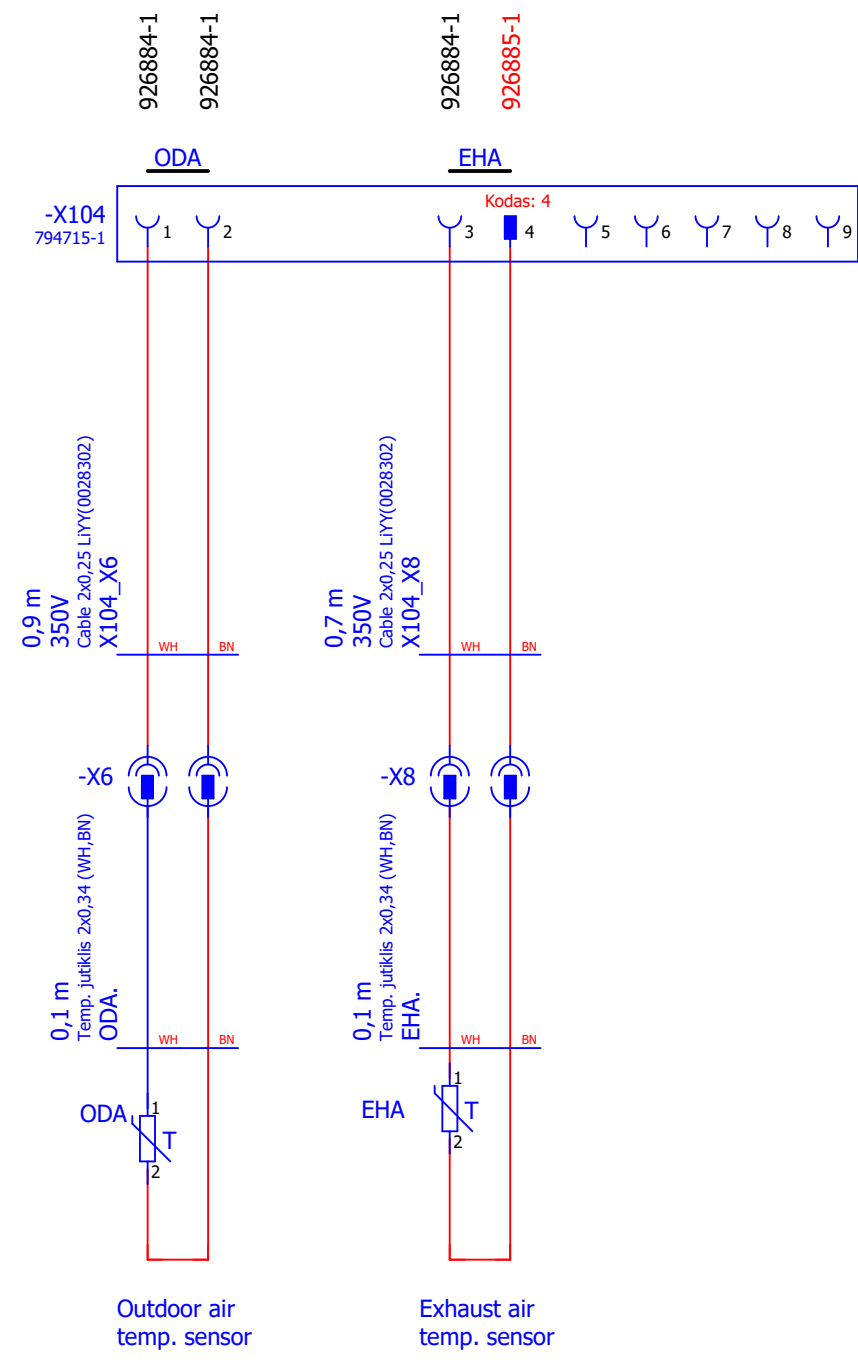
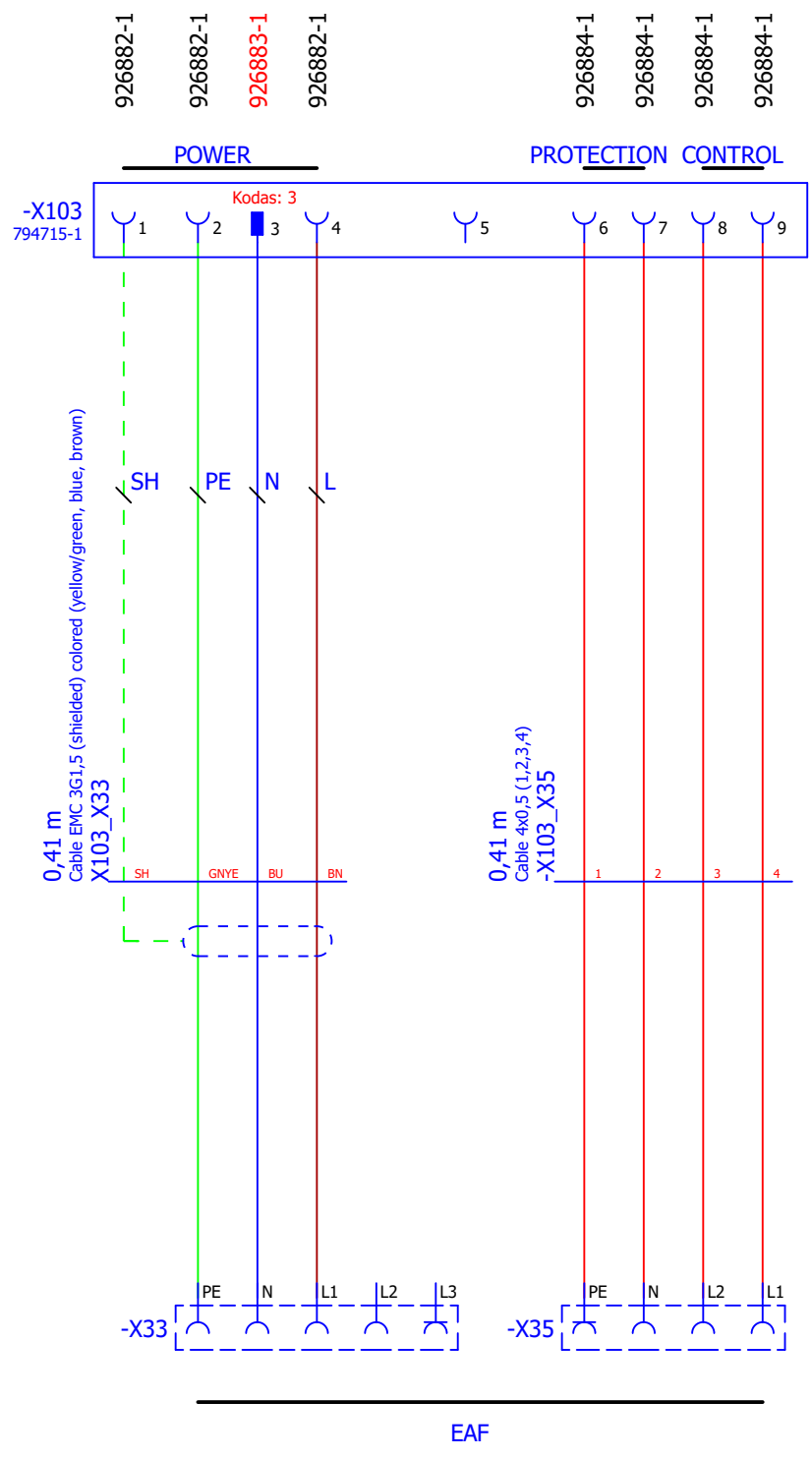

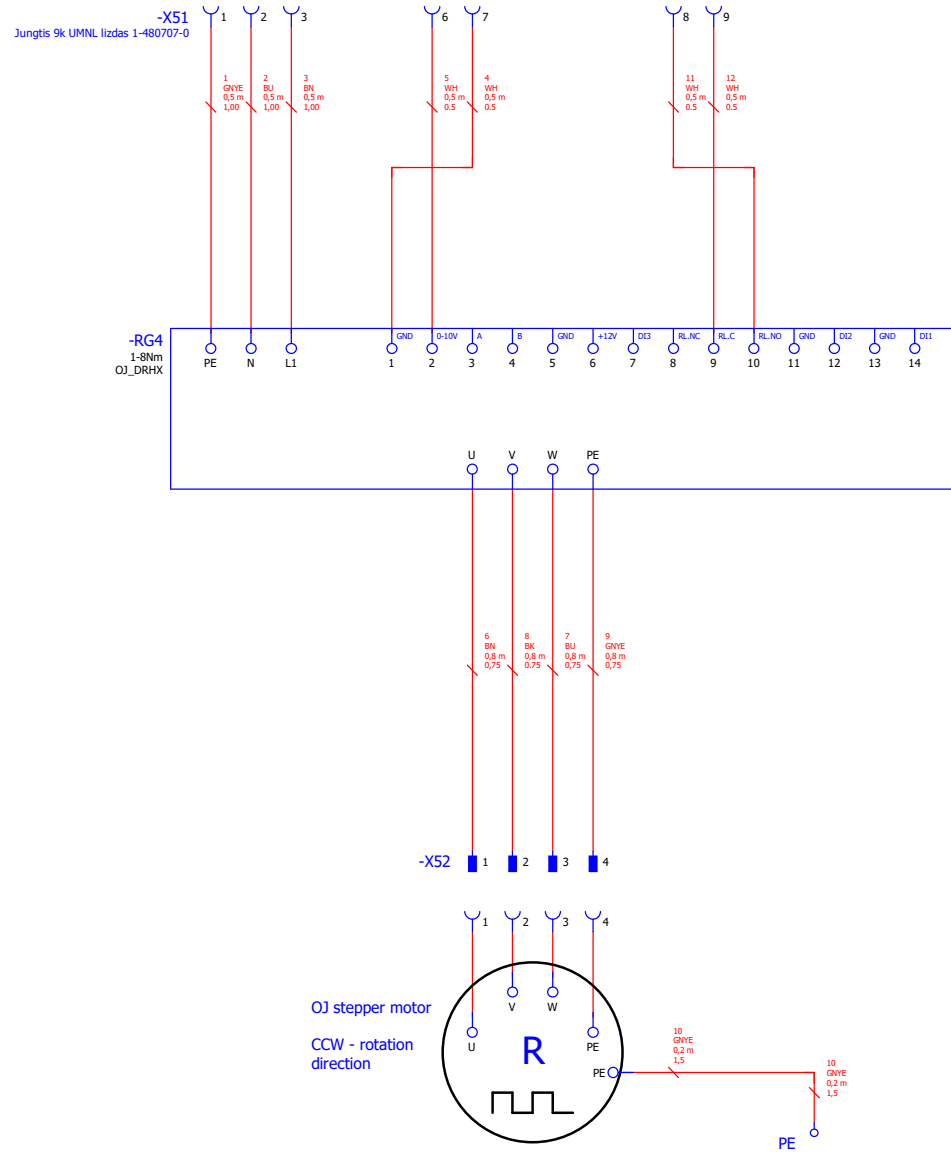

OJ stepper motor
CCW - rotation direction

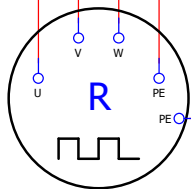

		Date	2023-10-24				221.2189.1-PS	= 221.2189	
		Ed.	justasbalys					+	
		Appr.						Project Nr.	Offer nr.
Modification	Date	Name	Original	Replacement of	Replaced by			Page	1 / 3

