

Modification	Date	Name	Date	Appr.	Original	Replacement of	Replaced by
			2024-06-10	Juanababyls		Control board for AHU MCB 219-2030	
SALDA							
Fans, Sensors, PSI, TI							
				Project No. 219-2030			
				Offer no.			
				= 219			
				Page 2 / 19			

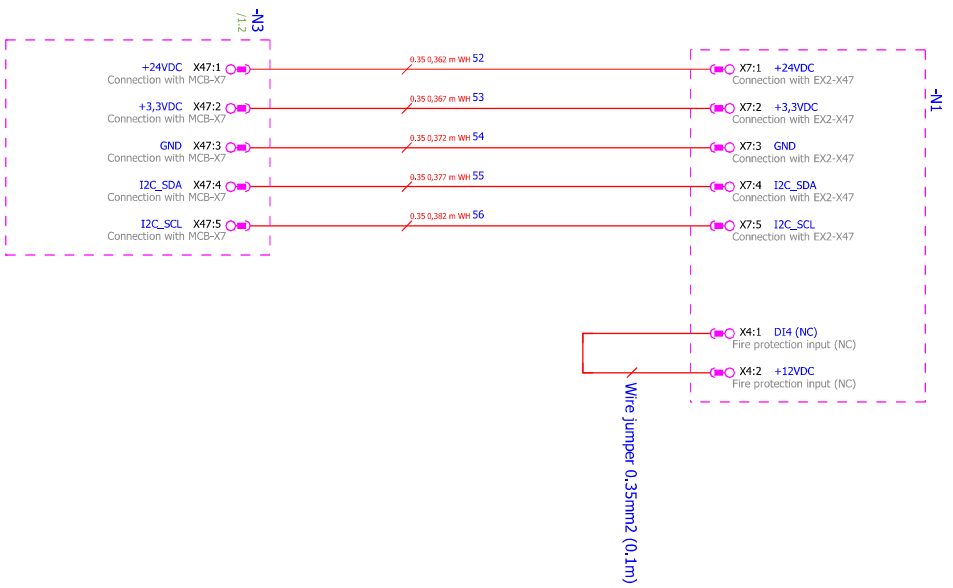

Modification	Date	Name	Date	Ed.	Appr.	Original	Replacement of	Replaced by
			2024-06-10		Juanababys		Control board for AHU MCB 219-2030	
SALDA								
Rotor, PS2, Communication								
Project No.	219-2030	Offer no.						
Page	= 219							
Page	3							
Page	3 / 19							

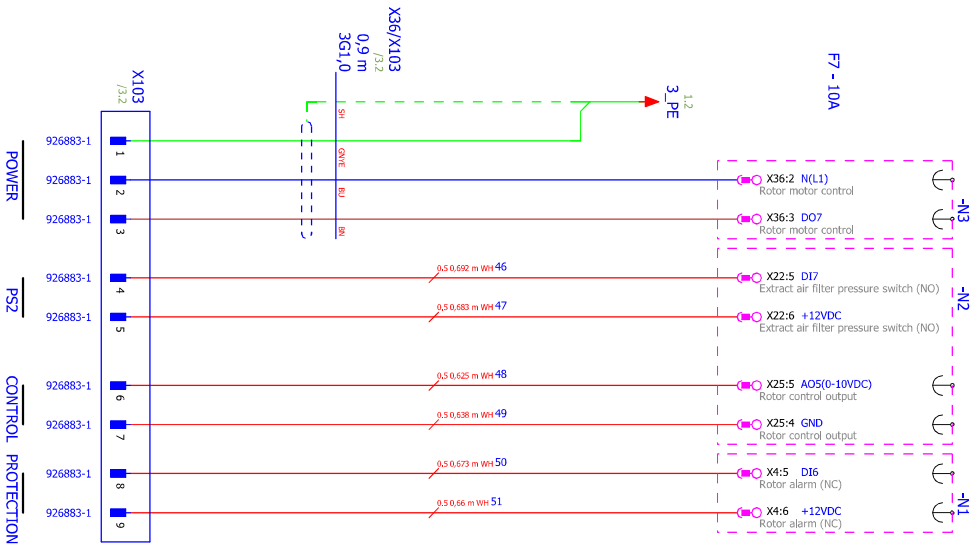
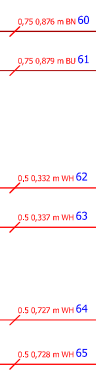
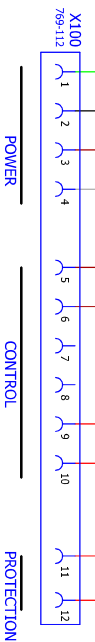
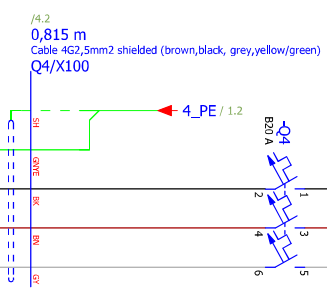
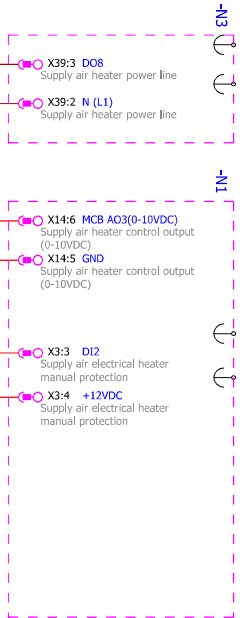

Modification	Date	Name	Date	2024-06-10	Control board for AHU MCB 219-2030	Heater	Project N° 219-2030	Offer n°	= 219	Page 4 / 19
			Ed.	Juanababys	Replaced by					
			Appr.							
			Original							



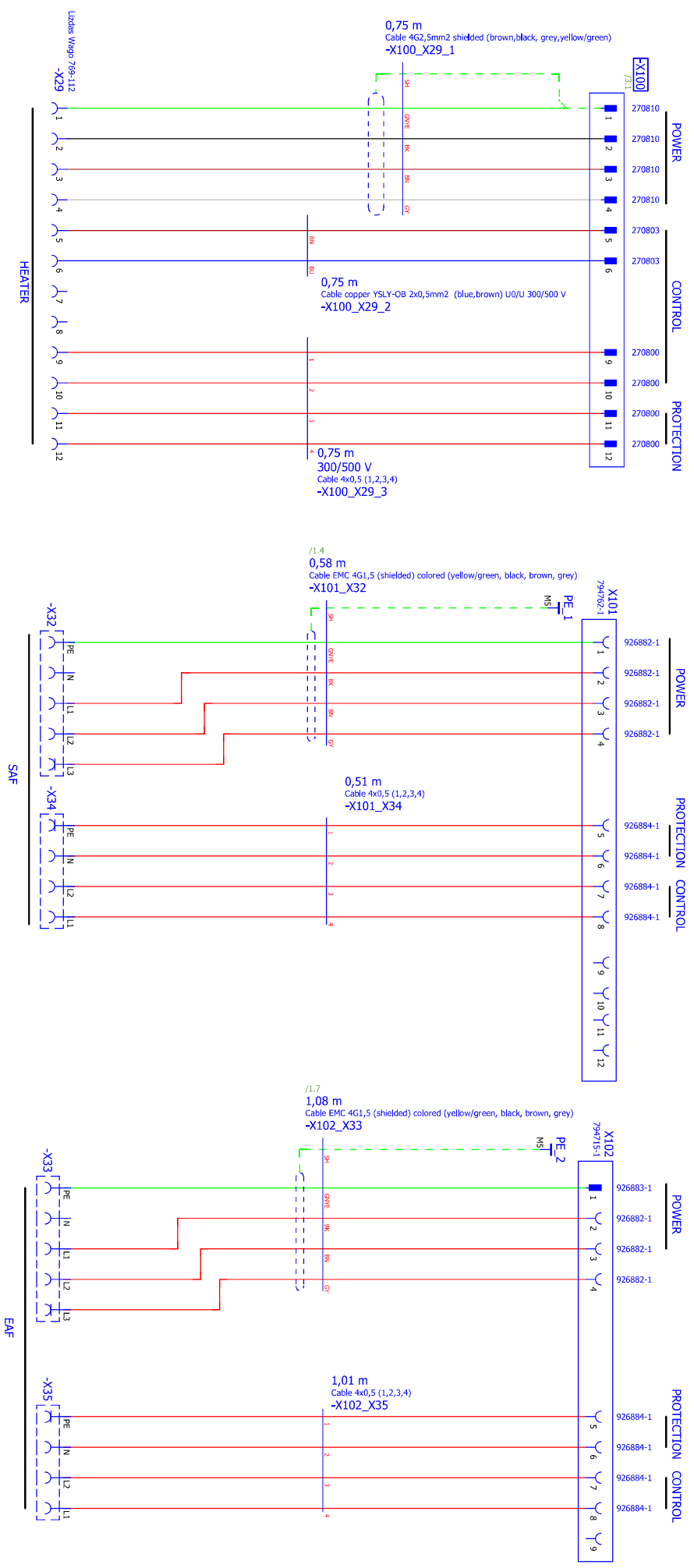

Modification	Date	Name	Date	Appr.	Original	Replacement of	Replaced by
			2024-06-10	Juanaabelys			
XX SALDA							
221.2781-PS							
Project No.	Offer no.		= 221.2781				
Page	Page		Page		1		
Page	Page		Page		2 / 10		

Modification	Date	Name	Date	Ed.	Appr.	Original	Replacement of	Replaced by
			2024-05-22		Vidas Petraitis			



221.2781-PS

Project No.	Offer no.	Page
		2
= 221.2781		Page
		3 / 10

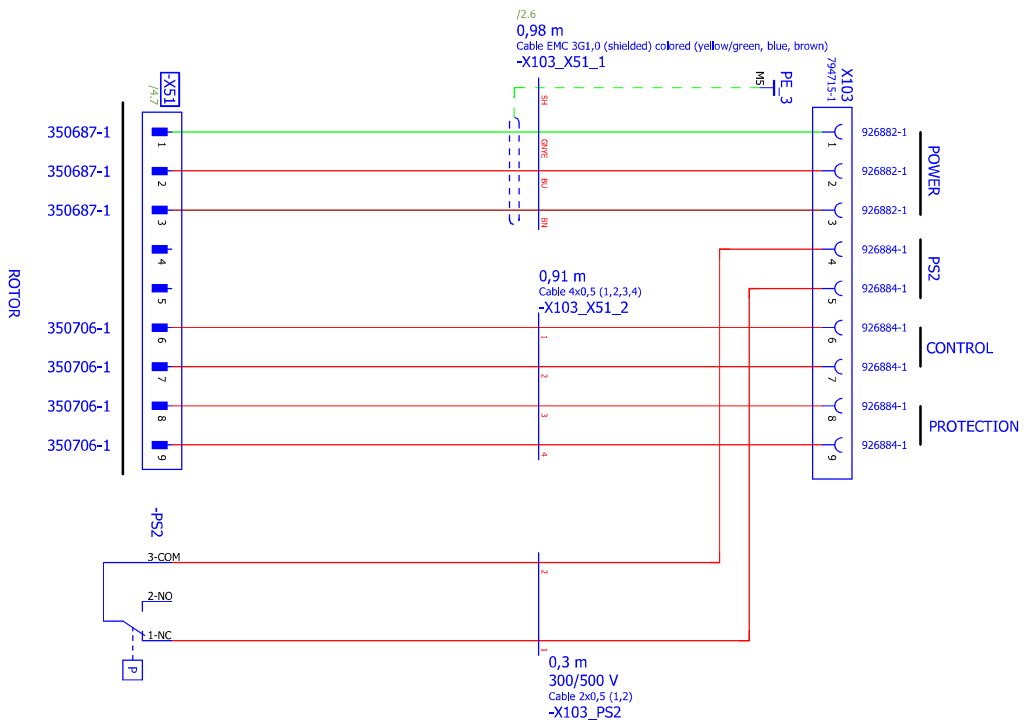
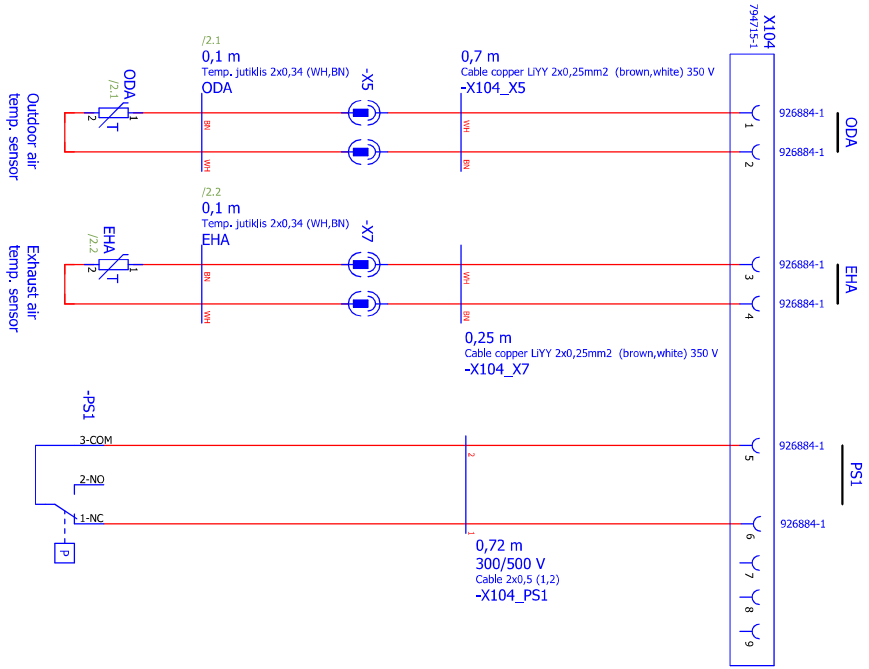

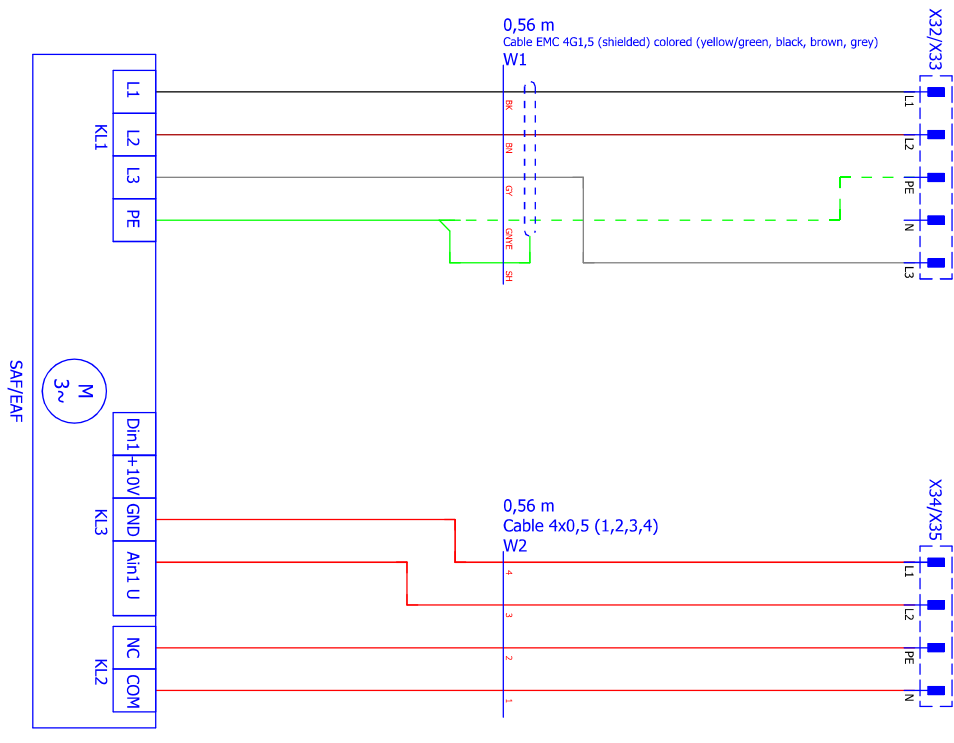

Modification	Date	Name
Ed.	2023-10-16	denfusleksandravici
Original		

Replacement of	Replaced by
Harness for fan 221-2566	

SALDA	221.2566-PS
--------------	-------------

Project Nr.	221-2566-PS
Page	1 / 2
Page	1 / 2

Jungtis 9K UMNLL Izdas 1-480707-0

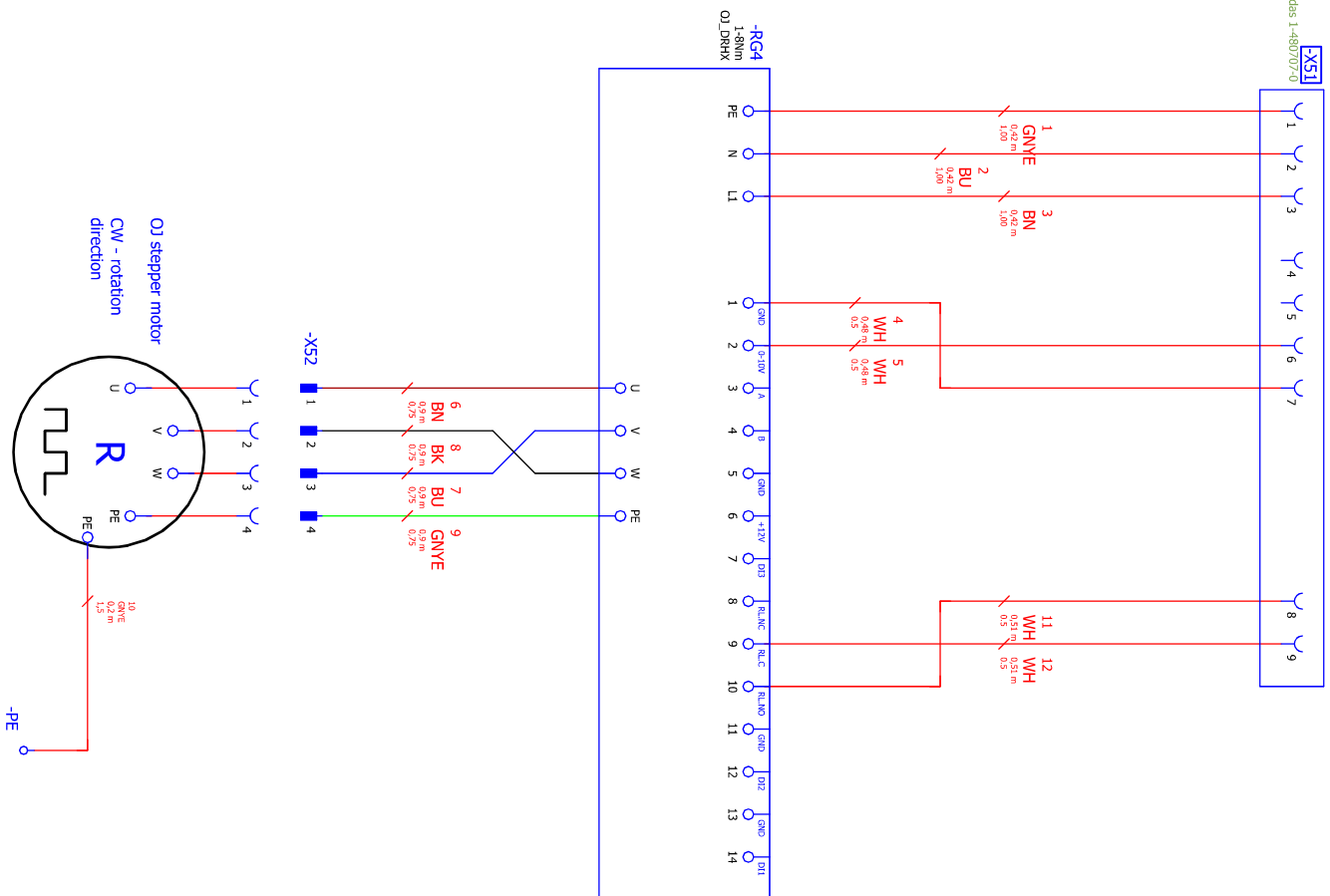

OJ stepper motor
CW - rotação
direction

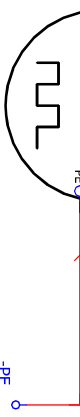

0	1	2	3	4	5	6	7	8	9
Modification	Date	Date	Ed.	2023-10-25	denfusiskandran/di	Replacement of	Replaced by	221.2573-PS	Project Nr. 221.2573
Date	2023-10-25	Ed.	denfusiskandran/di	Replacement of	Replaced by	221.2573-PS	Project Nr. 221.2573	Offer nr.	Page 1 / 2
=									Page 1
+									Page 1 / 2

0	1	2	3	4	5	6	7	8	9
---	---	---	---	---	---	---	---	---	---

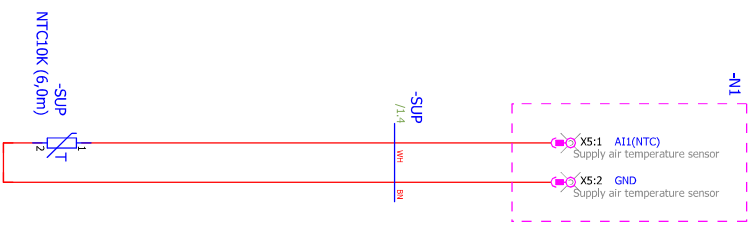

Modification	Date	2023-01-20	Replacement of	Replaced by	Project Nr.	Offer nr.	= SPT50 (SUP connection to MCB)
	Edi. Appr.	Jurabalsys					
Date							
Name							



SUP to MCB

