

L, mm W1, mm

RIS 1900 H	1084	2100
------------	------	------

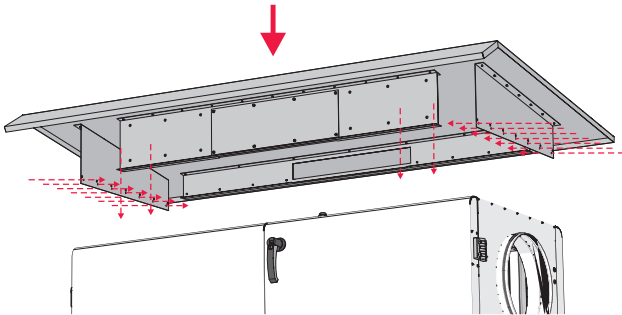
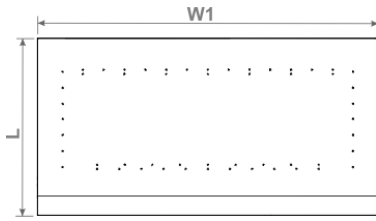

ROOF RIS/RIRS

- EN MOUNTING AND INSTALLATION INSTRUCTION
- LT MONTAVIMO IR INSTALIAVIMO INSTRUKCIJA
- DE MONTAGE- UND INSTALLATIONSANLEITUNG
- RU ИНСТРУКЦИЯ ПО УСТАНОВКЕ И МОНТАЖУ
- FR MANUEL DE MONTAGE ET D'INSTALLATION
- IT MANUALE INSTALLAZIONE E MONTAGGIO

SALDA

www.salda.lt

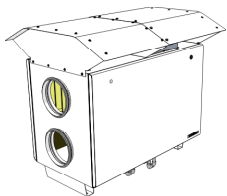

L, mm W1, mm W2, mm

RIS 700 H EKO 3.0	1002	700	642
-------------------	------	-----	-----

RIS 1900 H EKO 3.0	1115	1030	952
--------------------	------	------	-----

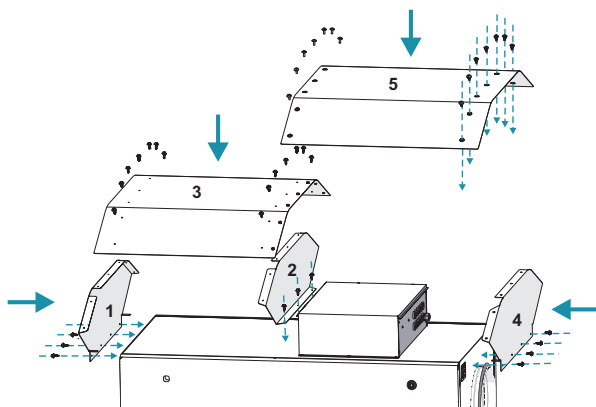
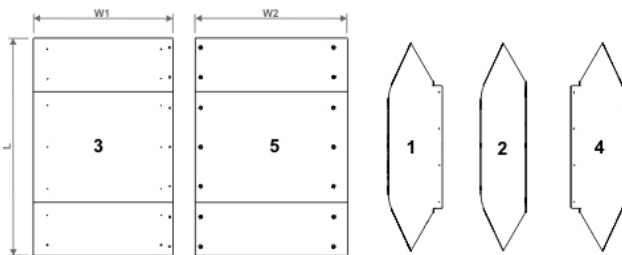

Raigainės g. 100
 Šiauliai LT-78109, LITHUANIA
 +370 41 540 415
 office@salda.lt



MAN000042



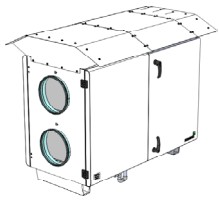

	L, mm	W1, mm	W2, mm	W3, mm
RIS 1200 H EKO 3.0	1077	670	640	350
RIS 2500 H EKO/EC	1216	755	707	799
RIS 5500 H EC	1394	895,5	849	1050,5
RIS 5500 H EKO	1900	914	914	914

	L, mm	W1, mm	W2, mm	W3, mm
RIRS 1200/1900 H EKO 2.0/3.0	1212	343	702	407
RIRS 2500 H EKO	1422	550,5	669	550,5
RIRS 3500 H EKO	1517	630,5	802	630,5
RIRS 5500 H EKO	1828	650,5	769	650,5

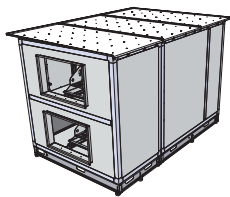
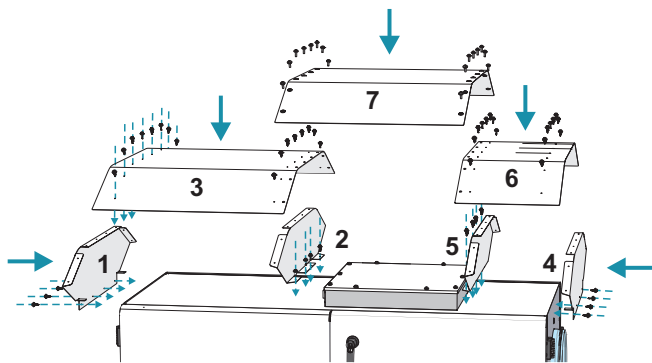
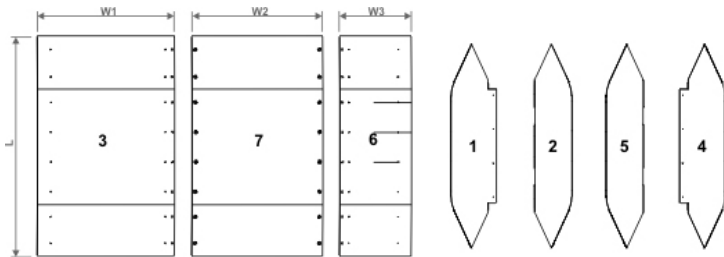

	L, mm	W1, mm	W2, mm	W3, mm
RIS 5500 H EKO 3.0	1900	914	914	914

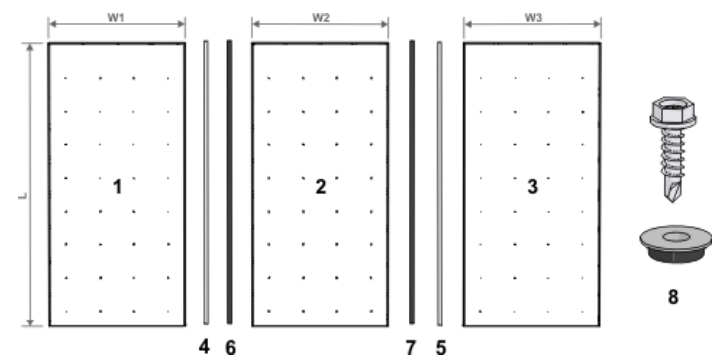

[EN] 4, 7 parts – E type (9x4) insulation rubber.
 [LT] 4, 7 detalės - E tipo (9x4) sandarinimo guma.
 [RU] 4, 7 детали – «Е» типа (9x4) резиновый уплотнитель.
 [DE] Teile 4, 7 –Dichtungsgummi E-Typ (9x4).

[FR] 4 et 7 - joint en caoutchouc de type E (9x4).
 [IT] 4, 7 : guarnizione in gomma di tipo E (9x4).

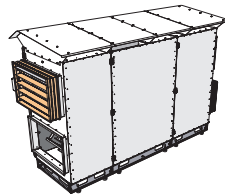
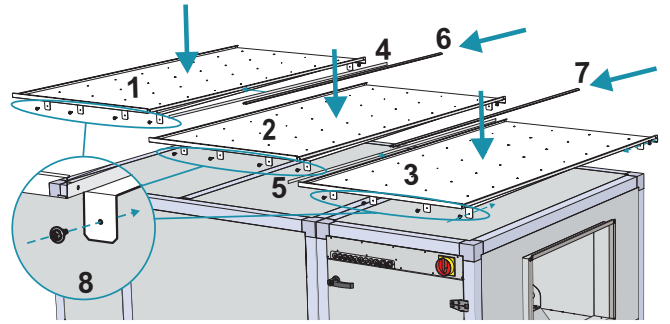

	L, mm	W1, mm	W2, mm	W3, mm	W4, mm
RIS 3500 H EKO	1244	840	747	700	749

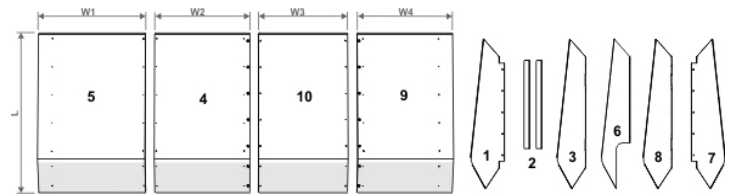

[EN] Part 2 – template for screwing the 3rd part.
 [LT] 2-a detalė - šablonas 3-ios detalės prisukimui.
 [RU] 2 деталь - шаблон крепления 3-ей детали.
 [DE] Teil 2 – Schablone für Befestigung von Detail 3.
 [FR] 2 - modèle pour la fixation de la 3ème pièce.
 [IT] 2: mascherina per il fissaggio del componente n.3.

