

POWER SUPPLY  
1IMX230V+N+PE; 50Hz



Modification	Date	Name

Date	2024-03-19
Ed.	Vidas Perutis
Original	
Replacement of	Control board for AHU
Replaced by	

Power supply	
--------------	--

Project Nr.	
Order nr.	



Modification	Date	Name	Date	2024-03-18	Control board for AHU
			Ed.	Vidas Perutis	
			Appr.		
			Original		
			Replacement of		
			Replaced by		



Rotor, PS1, Communication

Project Nr.	
Order nr.	

	= 219.1943
Page	3
Page	3 / 13

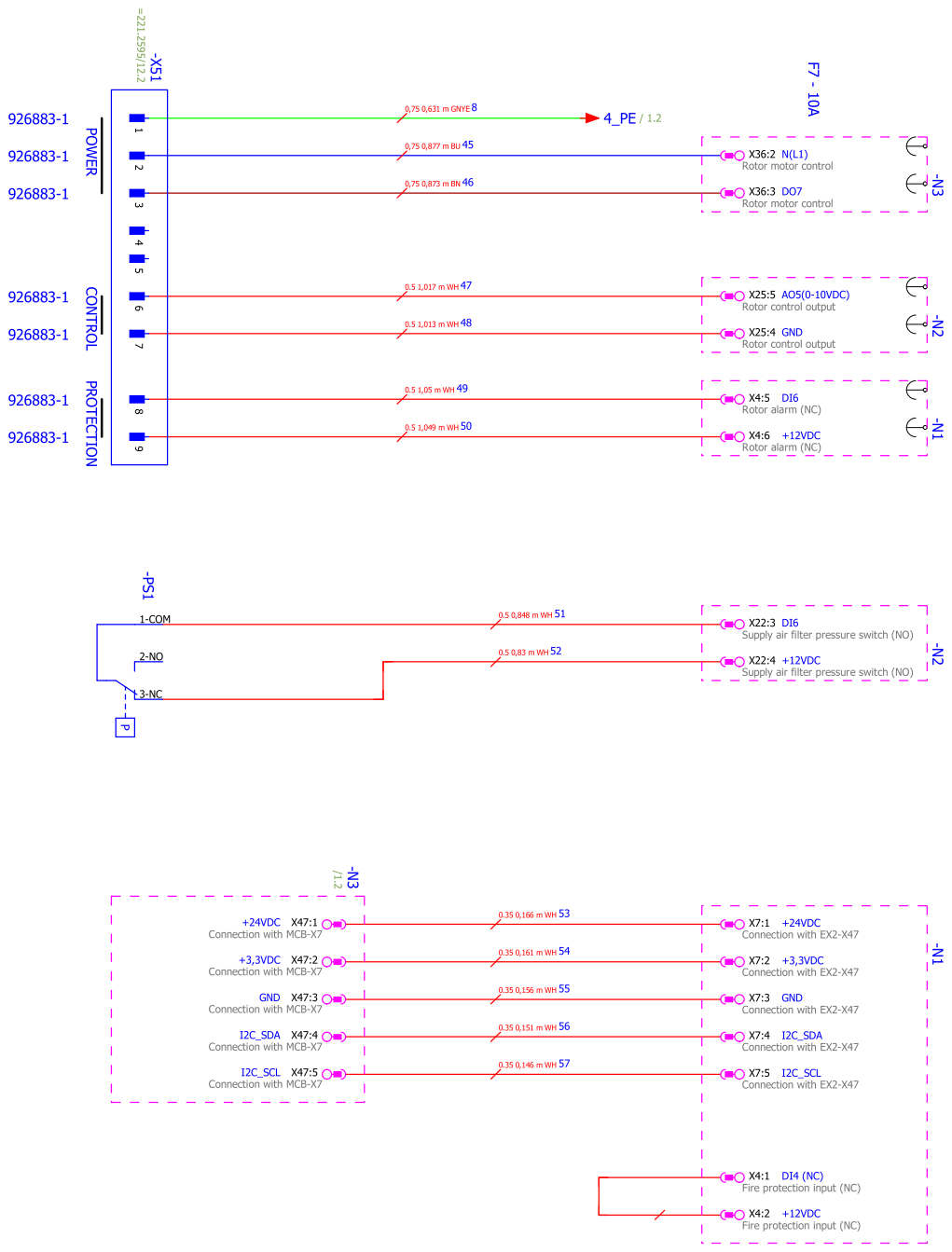

926883-1  
 926882-1  
 926882-1  
 926882-1  
 926884-1  
 926884-1  
 926884-1  
 926884-1

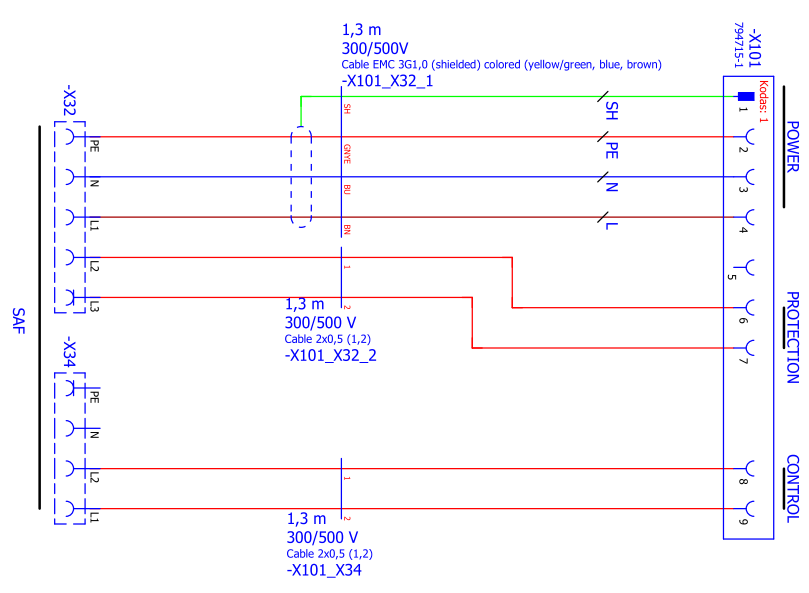

926884-1  
 926885-1  
 926884-1  
 926884-1

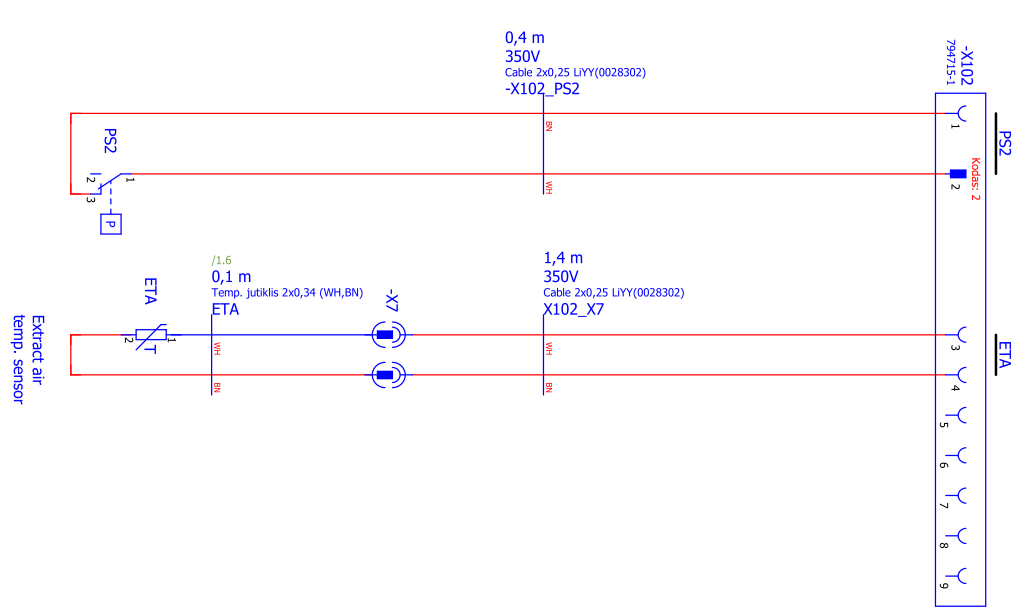

Modification	Date	Name	Date
	2024-01-29		
	Ed.		
	Apr.	justasabrys	
	Original		
	Replacement of		
	Replaced by		



Z21\_2630.1-PS

Project Nr.	Offer nr.	Page
		1
		1 / 9



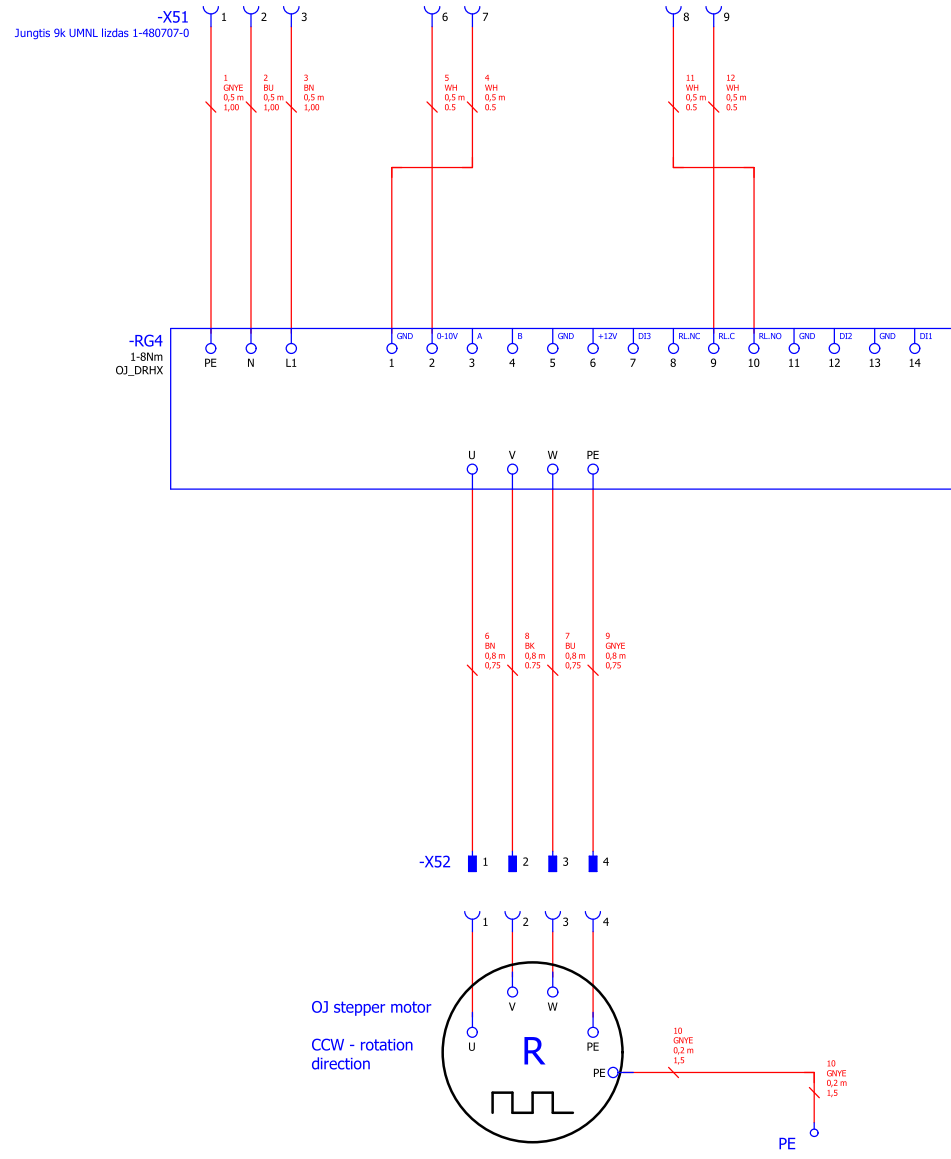

		Date	2023-10-24				221.2189.1-PS	= 221.2189	
		Ed.	justasbalys					+	
		Appr.						Project Nr.	Offer nr.
Modification	Date	Name	Original	Replacement of	Replaced by			Page	1 / 3

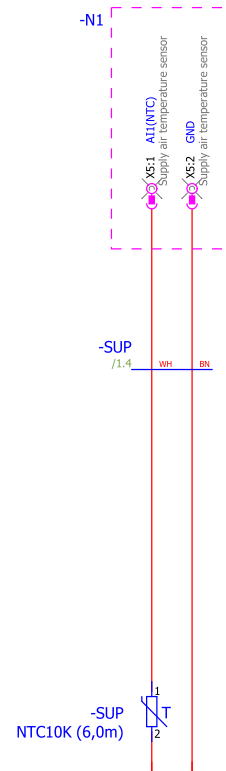

			Date	2023-01-20		
			Ed.	justasbalys		
			Appr.			
Modification	Date	Name	Original	Replacement of	Replaced by	



SUP to MCB

		= SP150 (SUP connection to MCB)
		+
Project Nr.	Offer nr.	Page 1 / 1

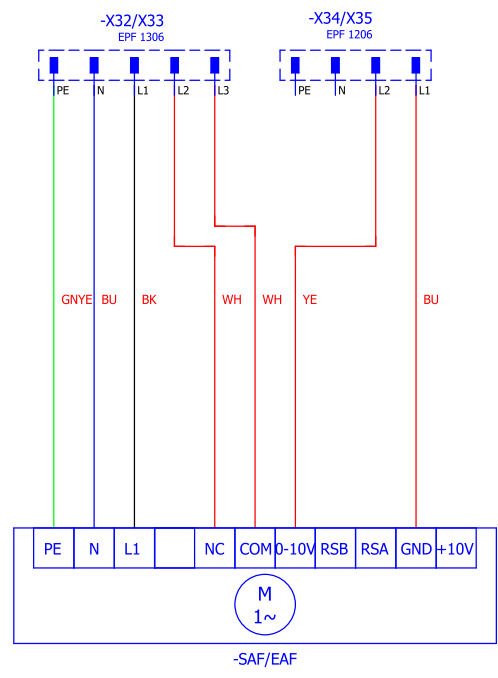

			Date	2023-03-08
			Ed.	justasbalys
			Appr.	
Modification	Date	Name	Original	
			Replacement of	Replaced by



Fans

		= SP148 (EBM fan)	
		+	
Project Nr.	Offer nr.	Page	1
		Page	1 / 1