



AMBERAIR COMPACT S-R H

EN OPERATION, INSTALLATION & MAINTENANCE INSTRUCTIONS



www.salda.it

1. CONTENTS

1. CONTENTS	2
2. SAFETY INSTRUCTIONS AND PRECAUTIONS	4
2.1. SAFETY SWITCH	4
2.2. DANGERS AND RISKS OF INJURY	4
2.3. SAFETY GUARDS	4
3. GENERAL PART	5
3.1. RANGE OF APPLICATION	5
3.2. PRODUCT INFORMATION	5
3.3. SYMBOLS AND MARKING	5
3.4. VERSIONS AND FAN ARRANGEMENT	6
3.4.1. ELECTRICAL CONNECTORS	6
3.5. MECHANICAL DESIGN	7
3.6. INTENDED USE	7
3.7. AIR HANDLING UNIT CONTROL	7
3.8. COMMUNICATION INTERFACE	7
4. INSTALLATION	9
4.1. GENERAL	9
4.2. RECEPTION OF GOODS	9
4.3. LIFTING	9
4.4. TRANSPORTATION AND STORAGE	10
4.5. UNPACKING	10
4.6. STANDARD PACKAGE OF COMPONENTS	11
4.7. MOUNTING LOCATION	12
4.8. THE DOCKING OF UNIT SECTIONS	13
4.8.1. MECHANICAL PART DOCKING	13
4.8.2. ELECTRICAL PART DOCKING	15
4.9. ROOF MOUNTING (ACCESSORY)	15
4.10. CONNECTION OF AN EXTERNAL HEATER/COOLER (ACCESSORY)	16
4.11. CONNECTION OF THE AIR DUCTS	16
4.12. SUPPLY AIR TEMPERATURE SENSOR INSTALLATION	17
4.13. EXTERNAL HEATER/COOLER (COMFORT BOX) CABLE ROUTING	17
4.14. MOUNTING POSITION OF MB-GATEWAY WEB MODULE	18
4.15. CONNECTING WATER COILS	19
4.16. CONNECTION OF THE UNIT TO THE ELECTRIC NETWORK	19
4.17. SYSTEM PROTECTION	20
4.18. EXTERNAL DEVICE CONNECTION	21
4.19. CONNECTION OF ACCESSORIES	22
4.19.1. OUTDOOR AND EXHAUST AIR DAMPERS	22
4.19.2. FIRE AND FIREPLACE SAFETY (SAFETY INPUTS, DAMPERS)	23
4.19.3. EXTERNAL HEATER, COOLER (COIL2)	25
4.19.4. EXTERNAL PREHEATER (COIL3)	28
4.19.5. AIR QUALITY SENSORS WITH ANALOG OUTPUT	30
4.19.6. INTEGRATED DX COOLER OR COMBINED HEATING/COOLING COIL	31
4.19.7. EXTERNAL INDICATION OUTPUTS AND CUSTOM SWITCHES	32

5. COMMISSIONING	33
5.1. GENERAL	33
5.2. OPERATIONS PRIOR TO THE FIRST START	33
5.3. CHANGE OF FANS CONTROL TYPE	34
5.4. PRESSURE SWITCH SETTING	36
5.5. ACCESSORIES SETUP	36
5.5.1. ACCESS OF CONFIGURATION PARAMETERS	36
5.5.2. AIRFLOW AND FIRE DAMPERS	37
5.5.3. FIRE AND FIREPLACE PROTECTION INPUTS	37
5.5.4. EXTERNAL HEATER, COOLER (COIL2)	37
5.5.5. EXTERNAL PREHEATER (COIL3)	37
5.5.6. AIR QUALITY SENSORS WITH ANALOG OUTPUT	38
5.5.7. CUSTOM SWITCHES	38
5.6. OPERATING THE UNIT	38
5.6.1. ST-SA-CONTROL REMOTE CONTROL PANEL AND SALDA AIR APP	38
5.6.2. WEB INTERFACE	40
6. MAINTENANCE	41
6.1. MAINTENANCE INTERVALS	41
6.2. OPENING THE DOOR	42
6.3. FRONT DOOR REMOVAL	42
6.4. BACK COVER REMOVAL	43
6.5. FILTER REPLACEMENT	43
6.6. HEAT EXCHANGER MAINTENANCE	44
6.7. FANS MAINTENANCE	44
6.8. ELECTRICAL HEATER MAINTENANCE	45
6.9. WATER COIL MAINTENANCE	45
6.10. CHECKING THE DAMPERS	45
6.11. CONTROL BOARD MAINTENANCE	46
7. TROUBLESHOOTING	47
7.1. SYSTEM NOTIFICATIONS	47
7.2. POSSIBLE FAULTS AND TROUBLESHOOTING	47
8. TECHNICAL DATA	48
8.1. DIMENSIONS	48
8.2. CONNECTION TO WIRING TERMINALS	80
8.3. ELECTRICAL DATA	85
8.4. FILTER DATA	89
8.5. SAFETY DATA	89
8.6. PIPING AND INSTRUMENTATION DIAGRAM	90
9. APPENDICES	93
9.1. ECODESIGN DATA	93
9.2. THE COMPONENTS OF THE AIR HANDLING UNITS	97
9.3. DISPOSAL	97
9.4. DECLARATION OF CONFORMITY	98
9.5. WARRANTY	99
9.6. LIMITED WARRANTY COUPON	99



The manufacturer reserves the right to change this technical passport at any time without prior notice if some typographic errors or inaccurate information is found, as well as after improving the apps and/or the devices. Such changes will be included in the new issues of the technical passport. All illustrations are just for information and thus may differ from the original device. The newest manual version is available at <https://select.salda.it>

2. SAFETY INSTRUCTIONS AND PRECAUTIONS

Read these instructions very carefully before installing and using this equipment. Installation, connection and maintenance should be carried out by a qualified technician and in accordance with local regulations and legislation.

The company shall take no responsibility for the injuries or damaged property if the safety requirements are not followed, or the device is modified without the permission of the manufacturer.

Main safety rules

Danger



- Before carrying out any electrical or maintenance works, make sure that the device is disconnected from the mains and that all moving parts of the device have stopped.
- Make sure that the fans are not accessible through air ducts or branch openings.
- If any liquids on electric parts or connections that bear voltage are noticed, stop the operation of the device.
- Do not plug the device into the mains that differ from the one indicated on the label or on the housing.
- Voltage of the mains should comply with the electrotechnical parameters indicated on the label.
- The device should be earthed in accordance with the regulations on the installation of electric devices. Turning on and using an un-earthed device is not allowed. Follow the requirements specified on the device's labels that indicate danger.

Warnings



- Connection of electricity and maintenance of the device should be performed by qualified personnel only and in accordance with the manufacturer's instructions and safety requirements.
- In order to reduce the risk during installation and maintenance, suitable protective clothing must be worn.
- Beware of sharp angles while carrying out installation and maintenance works.
- Do not touch heating elements until they haven't cooled down.
- Some devices are heavy, you should be very careful while transporting and installing them. Use suitable lifting equipment.
- When connecting electricity to the mains, a circuit breaker of suitable size must be used.
- Use appropriate safety equipment (gloves, goggles) when performing installation or repair works.
- The equipment must be installed in accordance with the installation and maintenance instructions.
- The equipment should only be serviced according to the instructions below.
- If the power cable is damaged, it must be replaced by the manufacturer or its service representative, or by a person with the required technical qualifications.
- Do not drill into the unit's casing and do not use self-tapping screws if it is not pointed out in manual, as the internal components might be damaged.

Warning!



- If the device is installed in a cold environment, make sure that all connections and tubes are properly isolated. Intake and exhaust air ducts should be isolated in all cases.
- Openings of the ducts should be covered during transportation and installation.
- Make sure not to damage the coil when connecting the piping of the water coil. For tightening up, use a wrench/spanner.

Before starting up the device



- Make sure, that there are no strange objects inside the device;
- Manually check fans to make sure they are not stuck or blocked;
- Make sure that all components and accessories are connected in accordance with the wiring diagram or provided instructions.

2.1. SAFETY SWITCH

The safety switch is used for isolating the air handling unit from the electric power source. Starting and stopping of the unit should be performed by an external control device. The safety switch must be switched off before storing the unit or performing maintenance or repairs to the unit.

2.2. DANGERS AND RISKS OF INJURY

Danger caused by moving parts

Typical moving parts are impellers.

The unit doors with a lock prevent contact with the fans.



- **Do not open the doors while AHU is operating.**
- **Wait until the fans stop before opening the door.**
- **Keep the keys at a safe location separate from the AHU.**

2.3. SAFETY GUARDS

Cover of the electric equipment and automatics serves as a safety guard.

Only qualified electricians or trained service technicians are allowed to remove the cover.



- **The unit must be isolated from the power supply before removing the cover.**
- **During unit operation, all the safety guards must be installed and doors closed.**

3. GENERAL PART

3.1. RANGE OF APPLICATION

⚠ Not suitable for operation in pools, saunas and other similar premises.

The AmberAir Compact S units are designed for general ventilation applications such as offices, educational buildings, public buildings, shops, etc. Units with side duct connection can be installed outdoors if covered from the precipitation. If ducted accessories are mounted outdoors, they must be insulated.

AmberAir Compact S is designed to operate in surrounding and inlet air temperatures from -23°C to +40°C.

3.2. PRODUCT INFORMATION

This manual includes the information required for installing and maintaining the heat recovery unit type AmberAir Compact S manufactured by SALDA UAB. The units include the following model options:

AmberAir Compact S-R-1500-H-E-R-C1 AlZn

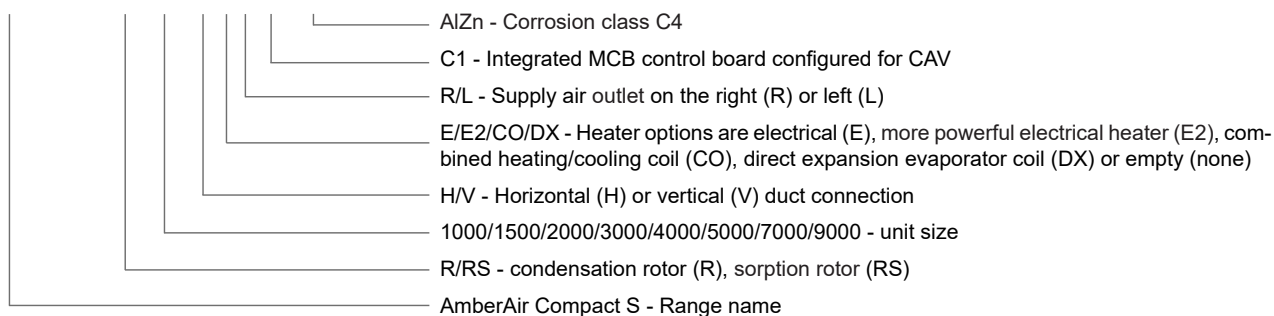

3.3. SYMBOLS AND MARKING

⚠ Warning – pay attention

i Additional information

Apply the technical label on the unit (in an easily accessible location) or on the dashed location of the technical manual to keep the important information about the unit.

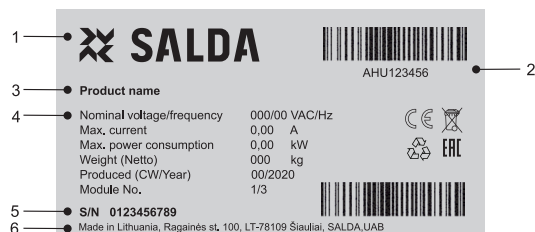

Fig. 3.3.1 Technical label

1 - Logo; 2 - Product code (SKU); 3 - Product name; 4 - Technical data; 5 - Serial number; 6 - Production place.



Fig. 3.3.2 Indication for duct connection.

ODA - outdoor air; SUP - supply air; ETA - extract air; EHA - exhaust air.

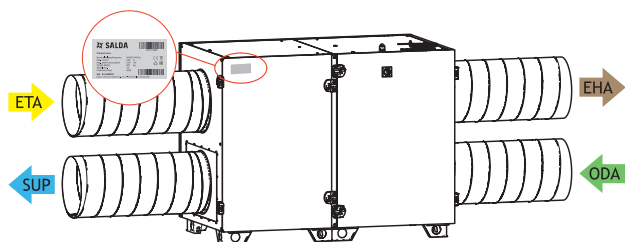

Fig. 3.3.3 Technical label place and air duct indication AmberAir Compact-S-R-1000-2000-H (left version)

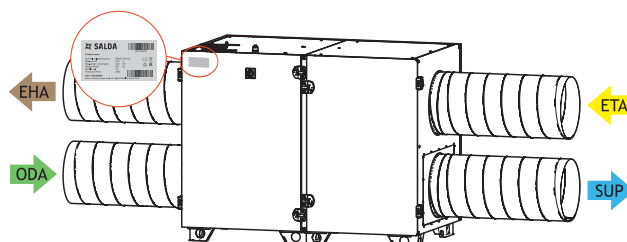

Fig. 3.3.4 Technical label place and air duct indication AmberAir Compact-S-R-1000-2000-H (right version)

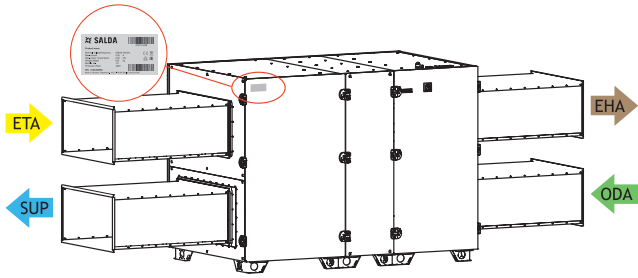

Fig. 3.3.5 Technical label place and air duct indication AmberAir Compact-S-R-3000-4000-5000-H (left version)

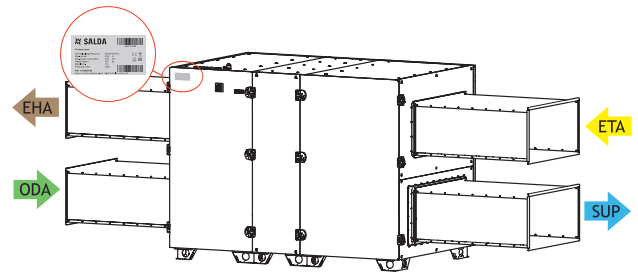

Fig. 3.3.6 Technical label place and air duct indication AmberAir Compact-S-R-3000-4000-5000-H (right version)

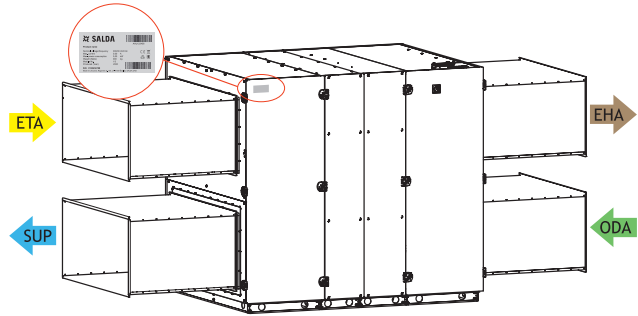

Fig. 3.3.7 Technical label place and air duct indication AmberAir Compact-S-R-7000-9000-H (left version)

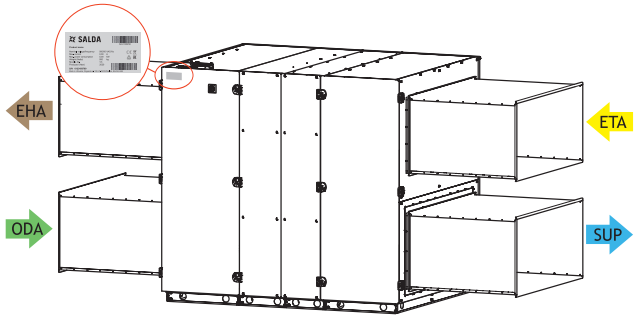

Fig. 3.3.8 Technical label place and air duct indication AmberAir Compact-S-R-7000-9000-H (right version)



NOTE. Ducts are not parts of the unit.

3.4. VERSIONS AND FAN ARRANGEMENT



The safety power switch is located on unit casing.

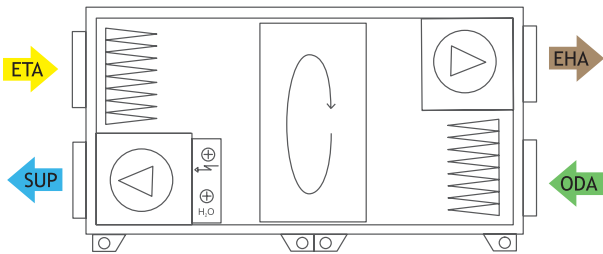

Fig. 3.4.1 AmberAir Compact S-R H (left version)

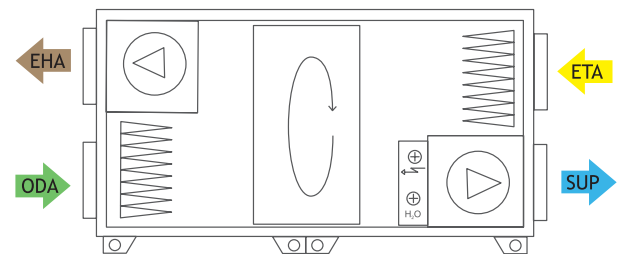
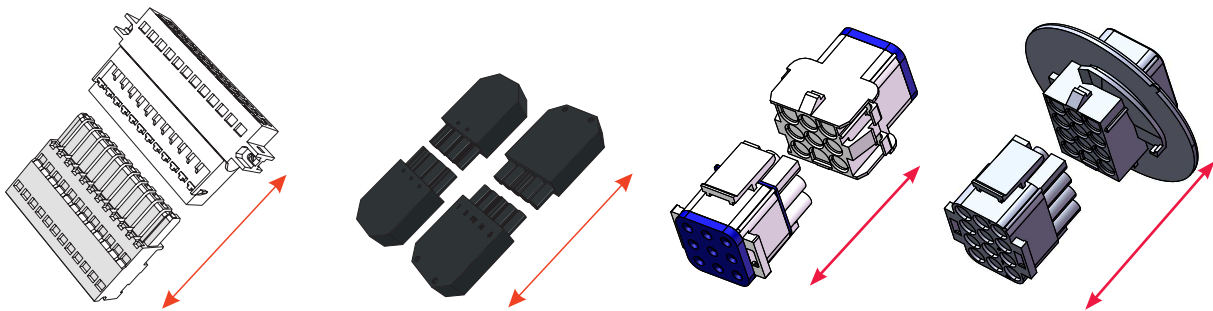

Fig. 3.4.2 AmberAir Compact S-R H (right version)

3.4.1. ELECTRICAL CONNECTORS

A lot of electrical components of the unit (electrical heater, fans, heat exchanger section, control board) are equipped with electrical connectors. Cables and wires of these components can be easily disconnected/connected from the unit using connectors when maintenance or repair is being implemented.



3.5. MECHANICAL DESIGN

The AmberAir Compact is available in 8 sizes for horizontal (H) duct connection version and 6 for vertical (V) duct connection version. The outer panel is painted in RAL7040. The handles are black. Internal surface: galvanized plated sheet steel or AlZn. Corrosion resistance class C3 or C4.

Panel insulation thickness – 50 mm (mineral wool).

AmberAir Compact is equipped with bag filters ePM10 65% (M5) and ePM1 55% (F7).

The supply air and extract air fans have backward-curved blades. The fans are direct-driven with a variable speed control.

Casing parameters: D1 (M), L1 (M), F9, T2, TB2.

3.6. INTENDED USE

Air handling units are designed to provide ventilation in premises and depending on settings, passive heat recovery, air heating or “free cooling”. Sound levels exceeding 60 dB(A) may occur depending on load and unit size (see select.salda.it for detailed information).

The unit is equipped with a heat exchanger and a heater (or cooler) to compensate for heating/cooling losses during room ventilation, so we do not recommend using the unit as the main source of room heat/cold. The unit may not reach the set supply air temperature if the actual room temperature differs significantly from the desired one, as this will cause the heat exchanger to operate inefficiently.

The device is not designed to transport solid particles by air. The device must not be operated in rooms where there is a risk of explosive gases being released.

We recommend not to switch off the device during the first year of operation, but to leave it operating in the minimum (20%) mode. Due to the moisture in the structures of the new building, condensation is possible both inside and outside the unit. Continuous operation of the device will significantly reduce the risk of condensation.

We recommend that you always keep the appliance switched on, as this will ensure a good indoor climate and reduce the risk of condensation on the walls. The device can be switched off when a service inspection is performed or filters are changed.

If the unit is installed in a room with high humidity, there is a high potential for condensation to form on the walls of the unit in cold weather outdoors.

3.7. AIR HANDLING UNIT CONTROL

AmberAir Compact units have integrated efficient microcontroller-based MCB controllers. All unit's active components are controlled by the MCB controller. It has a lot of functions that can efficiently operate the air handling unit. Users have access to the controller configuration where the control settings can be changed, or new controllable devices can be added to the air control system. Users can also connect to the controller and monitor unit's status or change preferred environment settings.

3.8. COMMUNICATION INTERFACE

Air handling unit can be controlled with a remote-control panel, WEB interface or mobile app via MB-Gateway and BMS (building management system). More information is provided in the table below.

With MB-GATEWAY	Remote control panels	BMS direct connection	Wireless communication
Web interface SALDA AIR mobile application BMS over Modbus TCP/IP BMS over BACnet IP	ST-SA-Control	Modbus RTU (RS485)	MB-GATEWAY + WIFI router

Modbus RTU connects to X8 terminal block of MCB controller (see section “**CONNECTION TO WIRING TERMINALS**”). By default, the controller is configured with RS485 port settings:

Baud rate: 19200 bps
Data: 8 Bit
Parity: Even
Stop bit: 1
Modbus address: 1

X18 MCB connector is for the Remote controller.
 X19 MCB connector is for BMS.
 S1 DIP switch is for X19.

Switch	Position	Purpose
S1	1	120 Ohm termination load (On/Off)
	2	1 kOhm RS line pull-up (On/Off)
	3	1 kOhm RS line pull down (On/Off)

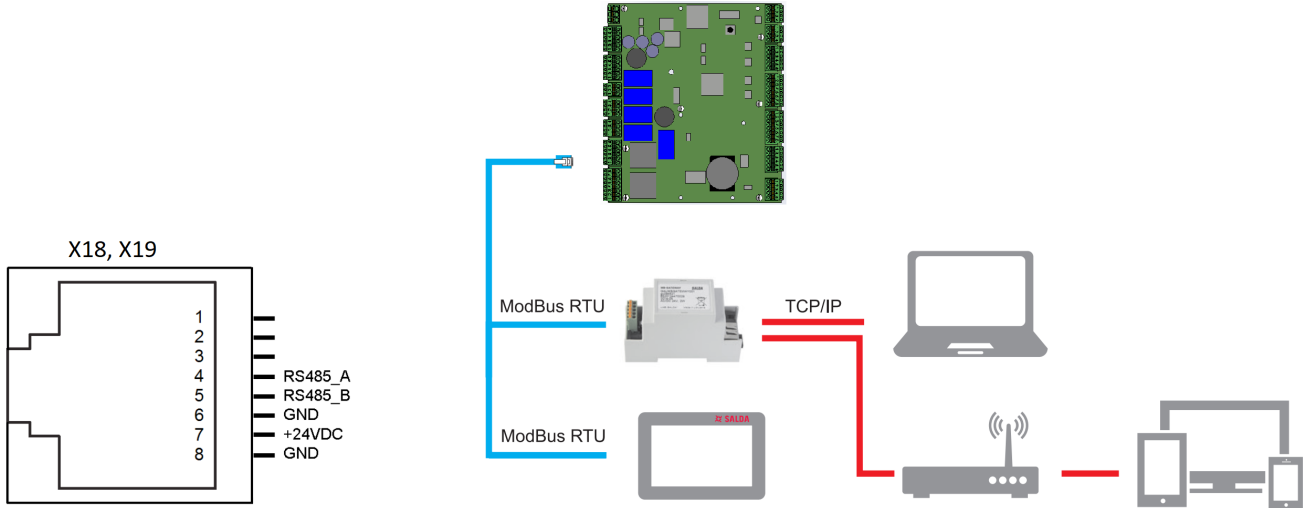

4. INSTALLATION

4.1. GENERAL

Personnel must be trained before starting to use the unit. Any damages to the unit or its components are not covered by warranty if the requirements are not fulfilled.

The product identification labels are located on the inspection side of the air handling unit.

The air handling unit is supplied in a special package.

Ordered accessories are supplied in separate packages.

4.2. RECEPTION OF GOODS

Each device is carefully checked before transportation. When receiving the goods, checking the devices for any damage made during transportation is recommended. If any damage to the unit is observed, immediately contact the representatives of a transport company. Please inform the representative of the manufacturer, if any deviation of the device is noticed.

4.3. LIFTING

The product can be lifted with a forklift or a crane using slings. When lifting with a forklift, the length of the fork must be greater than the length or width of the product (depending on the product version).

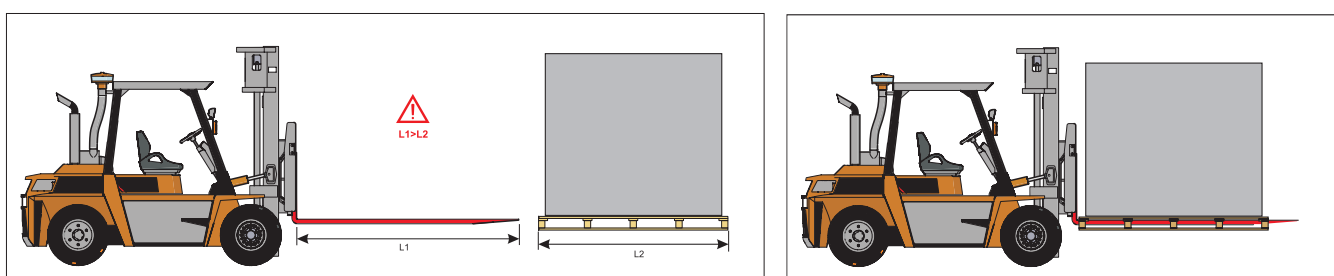

Fig. 4.3.1 AmberAir Compact S-R-1000-5000-H lifting with a forklift

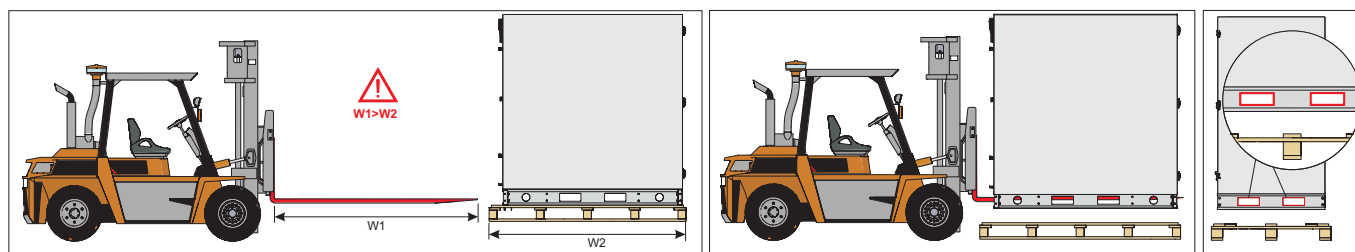

Fig. 4.3.2 AmberAir Compact S-R-7000-9000-H lifting with a forklift

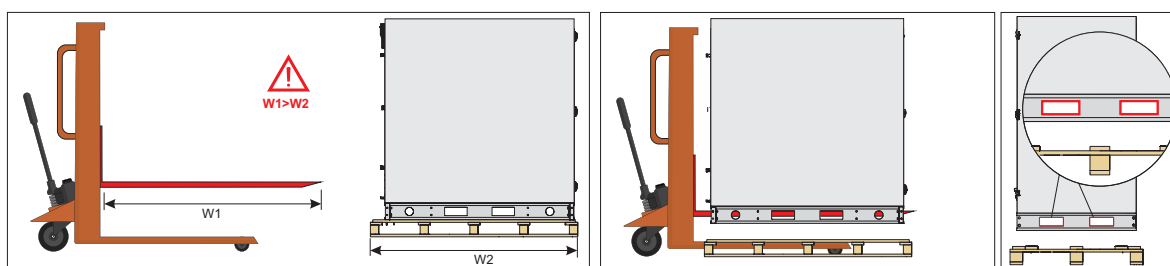

Fig. 4.3.3 AmberAir Compact S-R-7000-9000-H lifting with a hand lifter



To prevent damage to the casing, only a product placed on a pallet should be lifted.

When lifting the product with the slings, it is required to insert spacers between them to prevent damage to the casing.

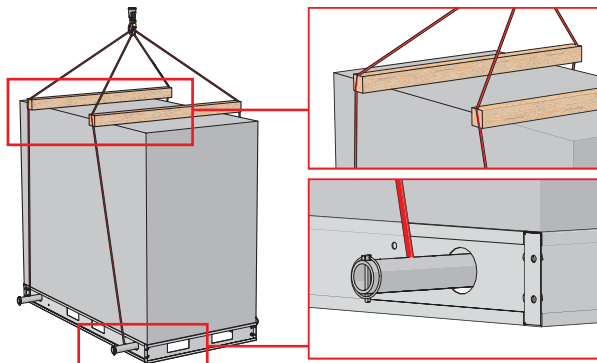

Fig. 4.3.4 AmberAir Compact lifting with slings

4.4. TRANSPORTATION AND STORAGE

- All units are factory-packaged to withstand normal conditions of transportation.
- When unpacking, check the unit for any damage made during transportation. Installing the damaged units is not allowed!
- The packaging is used for protection purposes only!
- When unloading and storing the units, use suitable lifting equipment to avoid damage and injuries. Do not lift units by holding on power supply cables, connection boxes, air extract or exhaust flanges. Avoid hits and shock overloads. Before installation, the units must be stored in a dry room with relative air humidity not exceeding 70 % (at +20 °C) and with an average ambient temperature ranging between +5 °C and +30 °C. The storage place must be protected against dirt and water.
- The units must be transported to the storage place or installation site using forklifts.
- The recommended storage period should not be longer than one year. In case of storing the units for a period longer than one year, checking if the fan bearings and motor rotate without difficulty (turning the impeller by hand) and if the electric circuit insulation is not damaged or the moisture has not accumulated must be performed before the installation of the unit.



Before installation Air Handling unit must be stored in clean and dry premises in their original packaging. If the unit is installed but not yet in use, all connection openings must be tightly closed and the unit must be additionally protected against environmental influences (dust, rain, cold, etc.).

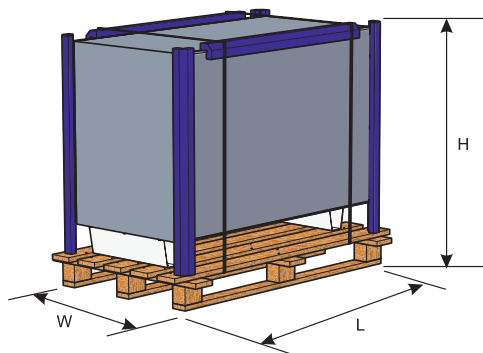

	H	W	L	Max. number of transported packages
AmberAir Compact S-R/RS	[mm]	[mm]	[mm]	[pcs.]
1000-H	1234	1000	1784	1
1500-H	1284	1000	1784	1
2000-H	1384	1100	1850	1
3000-H	1540	1300	2060	1
4000-H	1675	1450	2200	1
5000-H	1755	1500	2050	1
7000-H	2039	1785	2917	1
9000-H	2164	1960	2877	1

4.5. UNPACKING



Accessories may be packed together with the product. Prior to transporting the unit, the accessories should be unpacked first.

- Remove the film from the unit.
- Remove the bracing packaging tape that keeps the protective profiles in place.
- Remove the protective profiles.
- After unpacking the unit, examine it to make sure that no damage was made during transportation. Installation of damaged units is not allowed!

- Before commencing the installation of the unit, please check if all ordered equipment has been delivered. Any deviation from the ordered equipment list must be reported to the product supplier.
- The supply air sensor is placed inside a plastic bag and fastened to the top of the unit with adhesive tape.

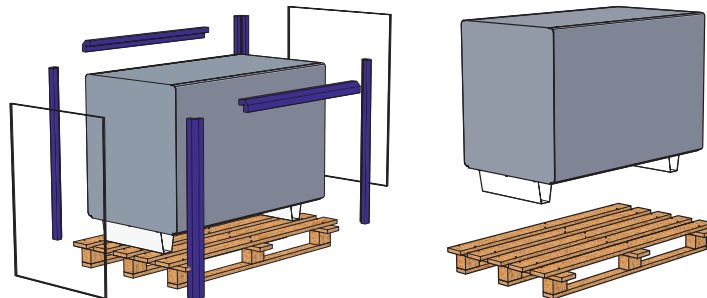

Fig. 4.5.1 AmberAir Compact S-R-1000-5000-H

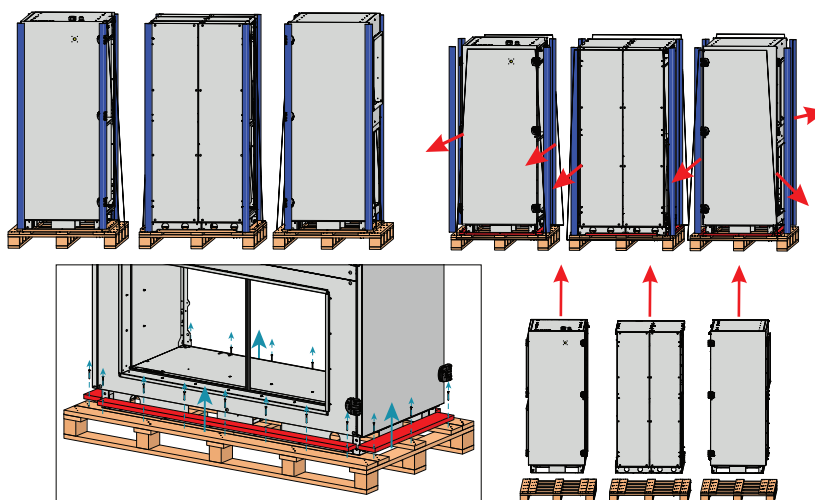

Fig. 4.5.2 AmberAir Compact S-R-7000-9000-H

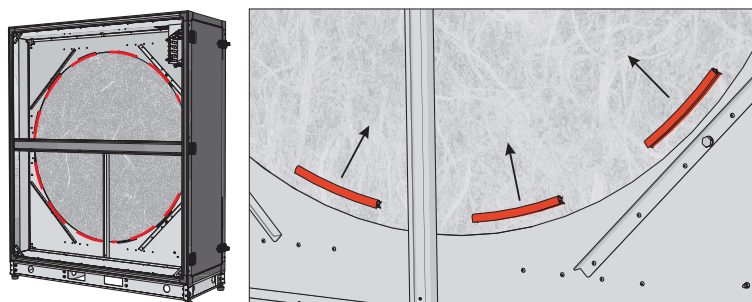

Fig. 4.5.3 Transportation rubber tapes removal (AmberAir Compact S-R-7000-9000-H)

4.6. STANDARD PACKAGE OF COMPONENTS

The separately packaged components of the unit are in the box and placed inside the product.

AmberAir Compact S-R/RS	1000-H	1500-H	2000-H	3000-H	4000-H	5000-H	7000-H	9000-H
Key L-shape	1	1	1	1	1	1	1	1
Manual	1	1	1	1	1	1	1	1
Ziplock bag 150/220 mm	1	1	1	1	1	1	-	-
Cardboard box 300x200x100	-	-	-	-	-	-	1	1
Bag 10/15	-	-	-	-	-	-	2	2
Bolt 8x30 DIN912	-	-	-	-	-	-	16	16
Spring washer 8 DIN125	-	-	-	-	-	-	16	16
Bolt 10x25 DIN933	-	-	-	-	-	-	8	8
Nut 10 DIN934	-	-	-	-	-	-	8	8
Spring washer 10 DIN127	-	-	-	-	-	-	8	8
Washer 10 DIN125	-	-	-	-	-	-	16	16
Sealable bag 25x35cm	-	-	-	-	-	-	2	2

L-shape key - for unlocking the product hinge/locks.
 Manual - placed in a folder and affixed on the outside of the product.

4.7. MOUNTING LOCATION

The air handling unit must be mounted on a relatively large and sturdy base, based on the weight of the unit and in accordance with building regulations. The base must be made of reinforced concrete or metal structures. If the unit is not equipped with adjustable height feet, it must be installed on a flat base. Vibration-damping gaskets must be fitted between the unit and the installation base.

Determine whether the installation space for the unit is sufficient, as the product must be accompanied by connecting cables, ducts and a condensate drainage system.

On the installation side, there must be enough place (1.5x product depth) for the door to open for service (replacing filters, removing the fan, cleaning the heat exchanger, etc.).

- Installation works should be carried out by qualified and trained staff only.
- When connecting air ducts, consider the labels on the casing of the unit.
- Before connecting to the air duct system, the connection openings of the ventilation unit should be closed.
- When connecting the ducts, the air-flow direction indicated on the device housing should be observed.
- Do not connect the bends close to the connection flanges of the unit. The minimum distance of the straight air duct between the unit and the first branch of the air duct in the supply and exhaust air ducts must be $3xD$, where D is the diameter of the air duct.
- It is recommended to use flexible connections (accessories). This will reduce the vibration transmitted by the unit to the air duct system and environment.
- If the ventilation unit is a wall-mounted device, it may transmit noise vibrations to the premises. Though the level of noise generated by the fans is admissible, we recommend mounting the unit at a distance of 400 mm from the nearest wall. Where this is not possible, we recommend mounting the unit on the wall of the room where the level of noise is not significant.
- Ducts are connected to the unit in such a way that they could be easily disassembled, and the coil could be removed from the unit when carrying out maintenance, service and/or repair works.



The protective film is used to protect the unit during transportation. It is recommended to remove the film, otherwise, oxidation signs may occur.

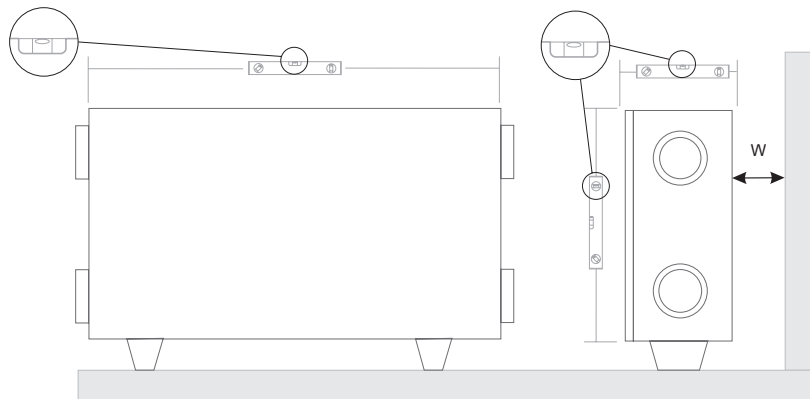

Fig. 4.7.1 Horizontal floor-mounting positions on floor ($W=400$ mm)

UNIT PLACING AND MOUNTING POSITIONING REQUIREMENTS

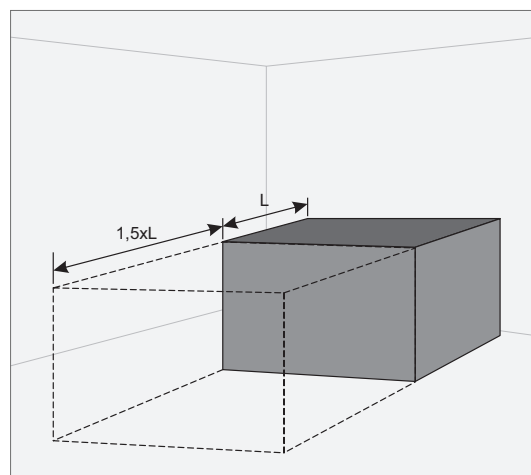

Fig. 4.7.2 Min. distance to open the door - $1,5xL$

FLOOR MOUNTING ON ADJUSTABLE FOOT (ORDERED AS AN ACCESSORY)

- The installation should be performed having positioned the units in the horizontal direction only.
- Install the antivibration feet.
- They must be adjusted without a gradient.

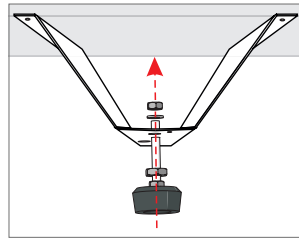

Fig. 4.7.3 Floor mounting

4.8. THE DOCKING OF UNIT SECTIONS

4.8.1. MECHANICAL PART DOCKING

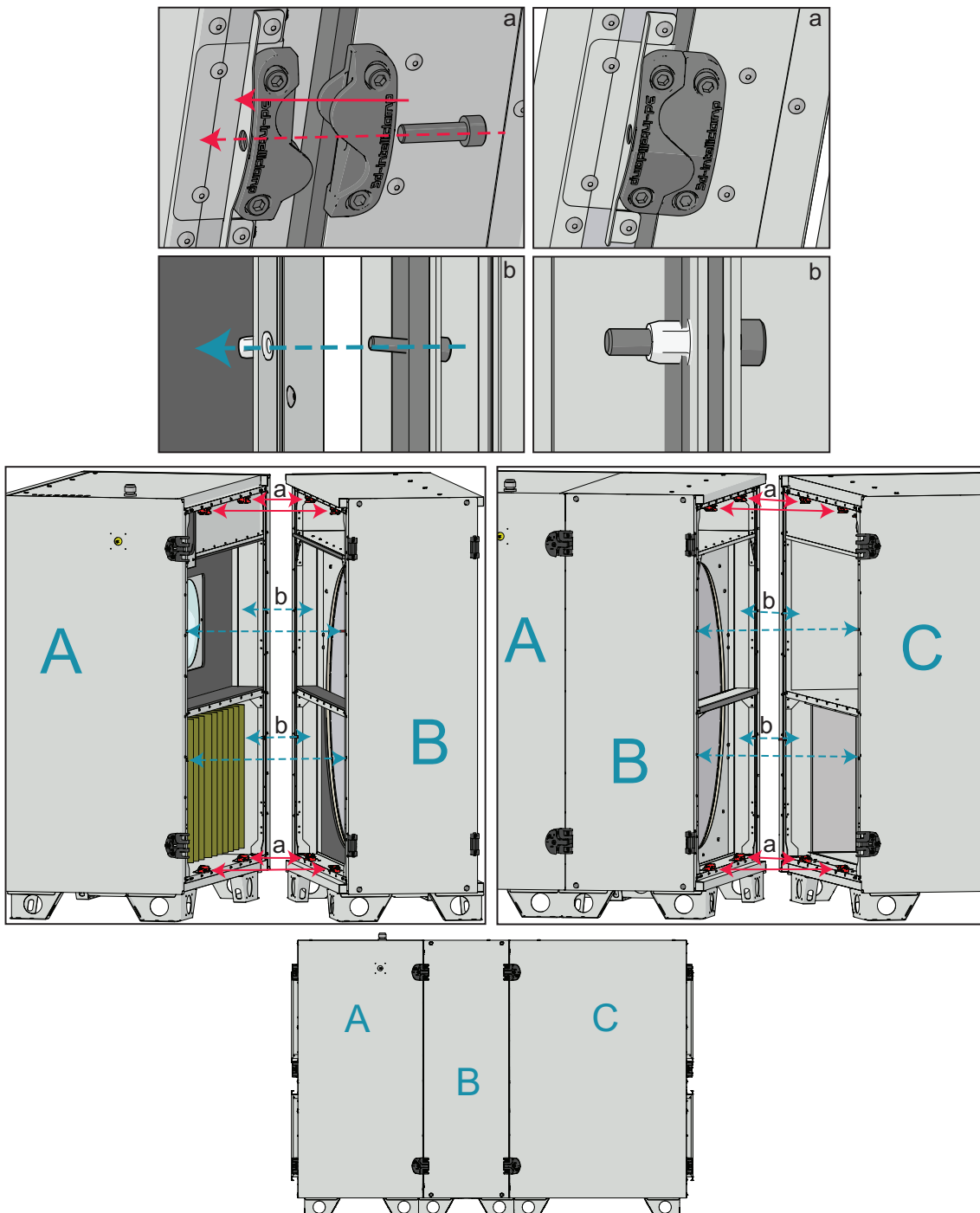

Fig. 4.8.1.1 AmberAir Compact S-R-2000-5000-H Connection of sections

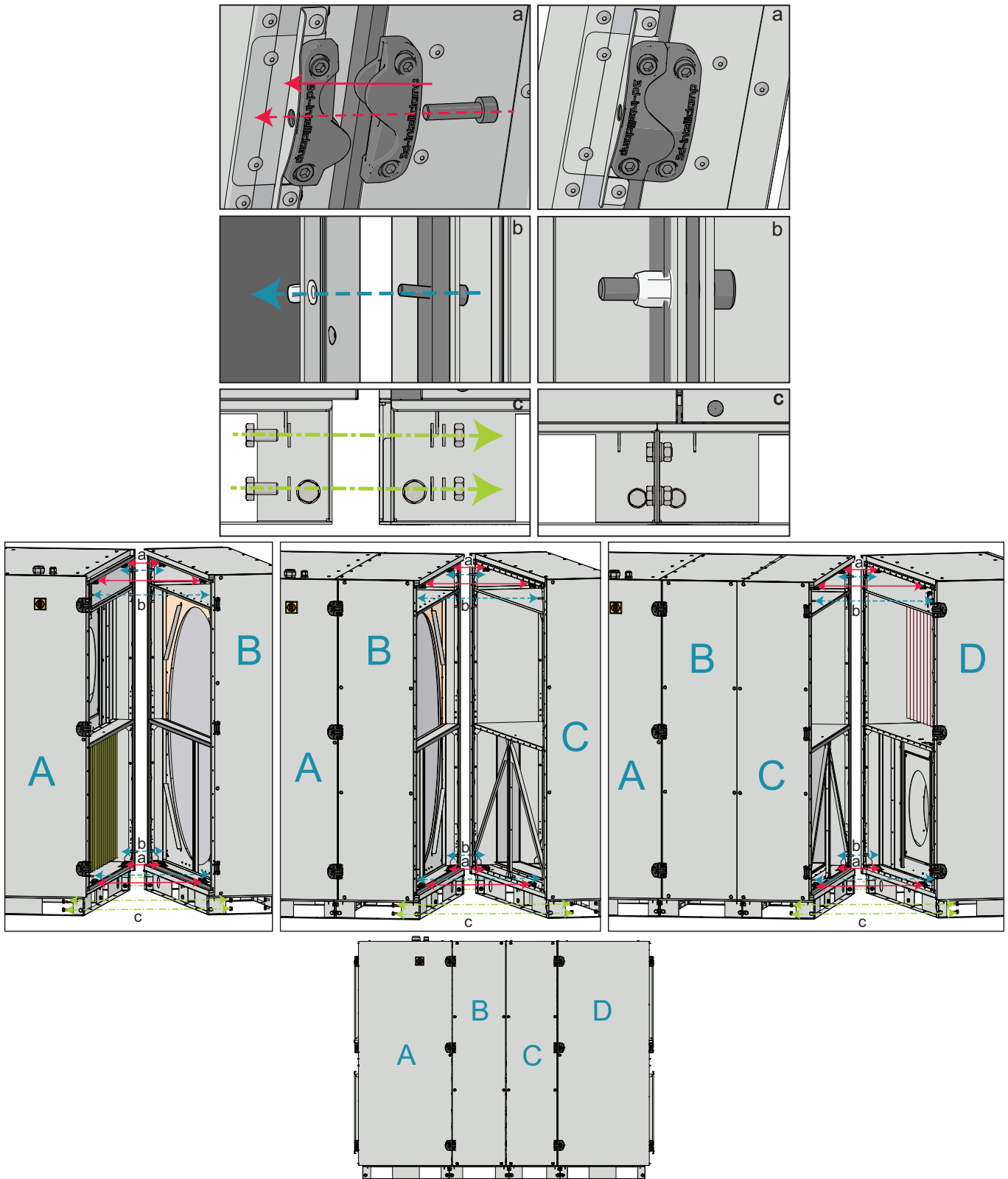

Fig. 4.8.1.2 AmberAir Compact S-R-7000-9000-H Connection of sections



NOTE. Before connecting sections, remove transportation rubber tapes from rotor wheel as shown in Fig. 4.5.3 on page 11.

4.8.2. ELECTRICAL PART DOCKING

After docking unit sections mechanically, electrical part of the sections must be connected:

- Connect all male connectors from control board section to the corresponding female connectors mounted on the side of other sections and heat exchanger (see section “**ELECTRICAL CONNECTORS**”).
- For units with more than 3 sections, connect male connectors to the corresponding female connectors of integrated heater (see section “**ELECTRICAL CONNECTORS**”).
- Connect all earthing wires between contiguous sections by screwing ring terminals with mounting bolts (one wire with two ring terminals for each additionally docked section).

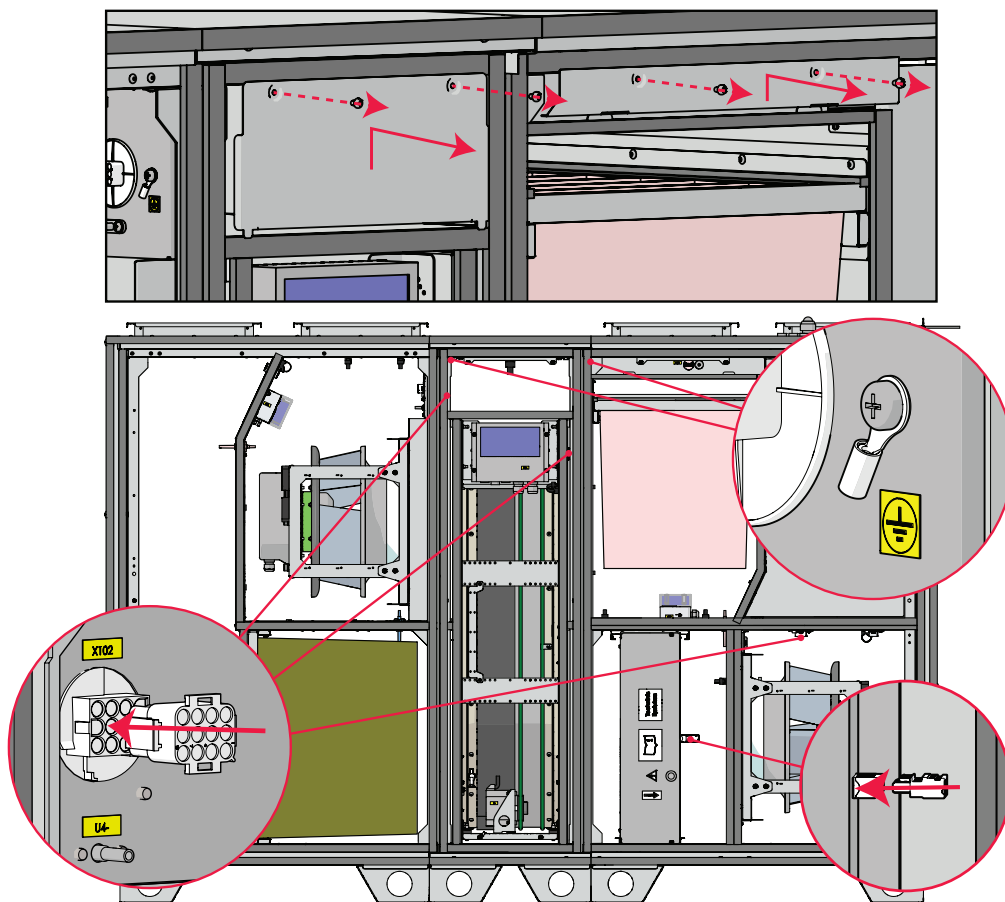

Fig. 4.8.2.1 Example of connection of earthing wires and connectors

4.9. ROOF MOUNTING (ACCESSORY)

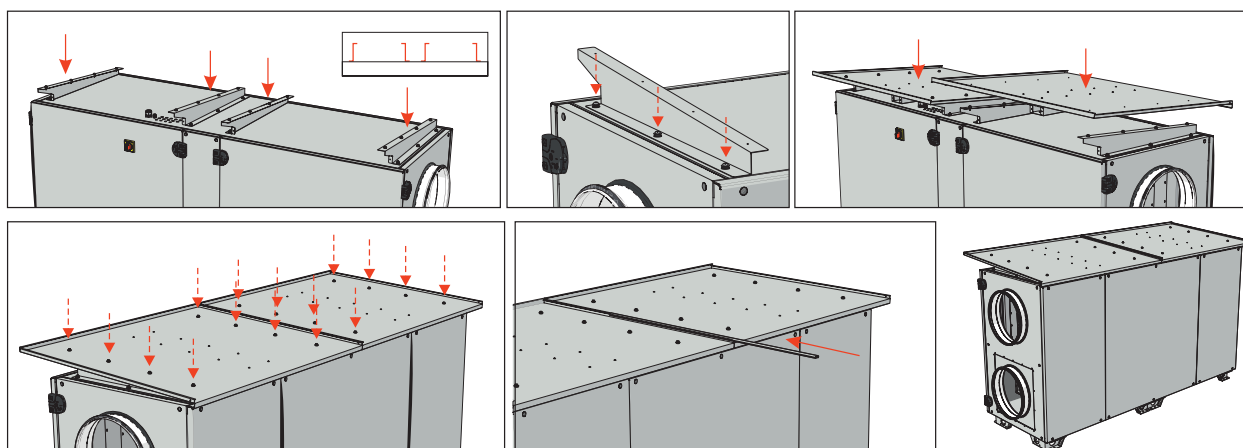

Fig. 4.9.1 Roof mounting

4.10. CONNECTION OF AN EXTERNAL HEATER/COOLER (ACCESSORY)

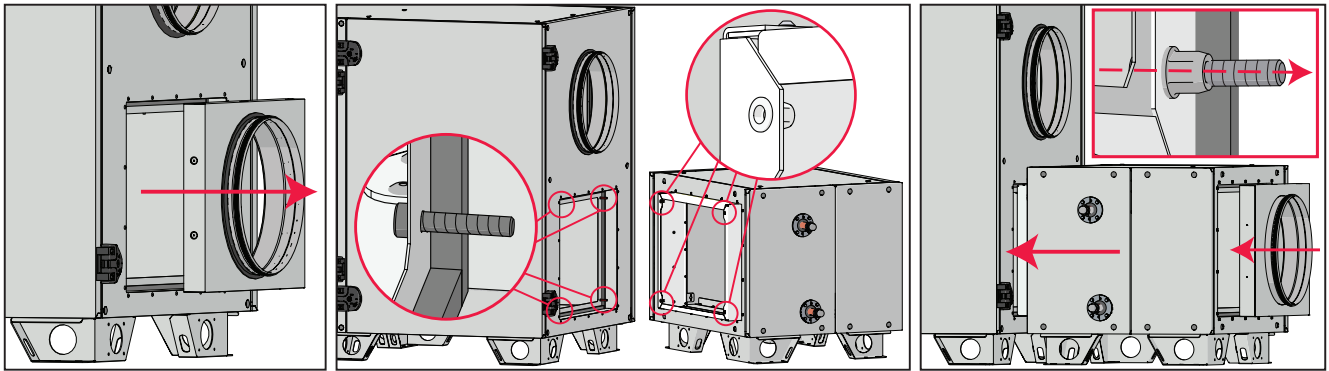

Fig. 4.10.1 External heater/cooler connection

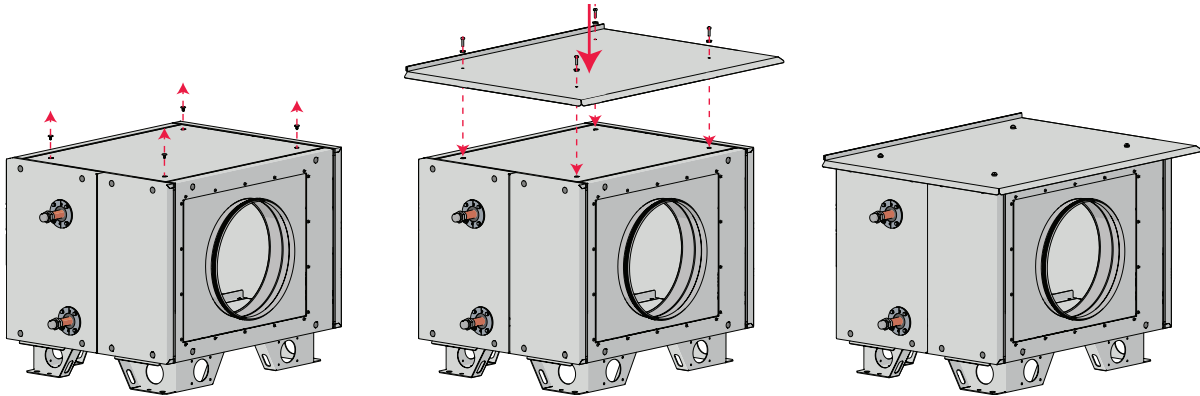

Fig. 4.10.2 External heater/cooler roof mounting

4.11. CONNECTION OF THE AIR DUCTS

- The connected air ducts must not be bent and must be fixed separately.
- Make sure that the fans may not be accessed through air duct heads. Otherwise, a protective grid should be installed. You may choose the grid from the range of products provided on our website <https://select.salda.it>.
- Do not reduce the diameter of the piping near the air inlet or exhaust ducts. If you want to reduce the airflow speed in the system, also to reduce pressure and noise level, you can increase the diameter.
- In order to reduce the level of noise in the air supply system, install silencers (see the chapter on air supply system installation).
- In order to reduce air loss in the system, the air ducts and profile components should be of class C or higher. The catalogue of the above-mentioned items can be found on our website <https://select.salda.it>.
- External air and exhaust system piping should be isolated in order to prevent heat loss and condensation.
- We recommend to maintain a distance of up to 8 meters between air intake and air exhaust ducts. The air intake point should be installed away from potential air pollution sources.
- When installing air ducts next to the ventilation equipment, brackets must be used. They suppress vibrations and assure secure installation of the various system parts. The necessary brackets can be found in our catalogue or on our website <https://select.salda.it>.
- Air ducts are often mistakenly connected in an inappropriate location. The ventilation units bear the labels indicating the correct air duct connection layout. Before starting up the system, carefully check if all related works have been performed properly.
- The air ducts can be connected to the air handling unit's rectangular connections by means of slip-clamps.

The ducts should be insulated according to local regulations and standards.

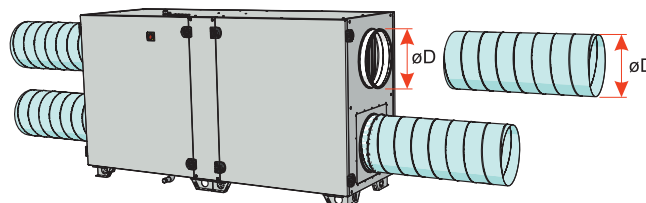





Fig. 4.11.1 AmberAir Compact S-R H

-  For flange diameters see section “DIMENSIONS”.
-  We recommend installing shut-off valves in the air intake and exhaust ducts. When operating the air handling unit with a water coil, a spring-loaded shut-off valve must be installed in the air intake duct.
-  The supply air temperature sensor is installed in the supply air duct after the coil, so it is necessary to leave space for the sensor in the straight duct.

4.12. SUPPLY AIR TEMPERATURE SENSOR INSTALLATION

The supply air temperature sensor is equipped with a B-meter-long cable. The sensor is connected to the X5:1 and X5:2 terminals of MCB controler. In order for the air handling unit to work properly, the supplied air temperature sensor must be installed inside the supply air duct. The minimum distance at which the sensor must be installed from the unit is A meters. Make sure that the sensor is installed in a place providing good access for technical service.

-  If the external heater/cooler is connected to the air handling unit’s supply air duct, the supply air temperature sensor must be installed at least A meters from the heater/cooler component.

After the place of supply air temperature sensor is chosen, drill a hole in the air duct. Insert the temperature sensor in the drilled hole and seal the hole around the temperature sensor tightly.

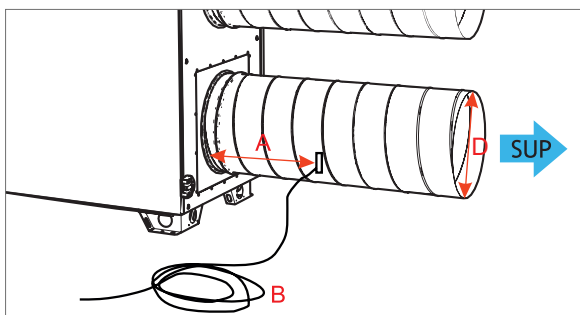

Fig. 4.12.1 Sensor installation for an air handling unit.
A - 3xD; B - 6m (A - min. distance; B - cable length; D - duct diameter).

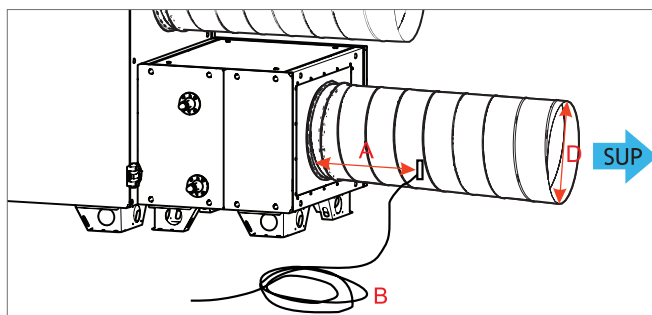

Fig. 4.12.2 Sensor installation when an external heater/cooler is used.
A - 3xD; B - 6m (A - min. distance; B - cable length; D - duct diameter).

4.13. EXTERNAL HEATER/COOLER (COMFORT BOX) CABLE ROUTING

When Comfort Box external heater/cooler is used, its electrical cables should be routed through the AHU to the control box through the existing cable seals as displayed in the picture below. Electrical connection diagrams can be found in section “EXTERNAL DEVICE CONNECTION”.

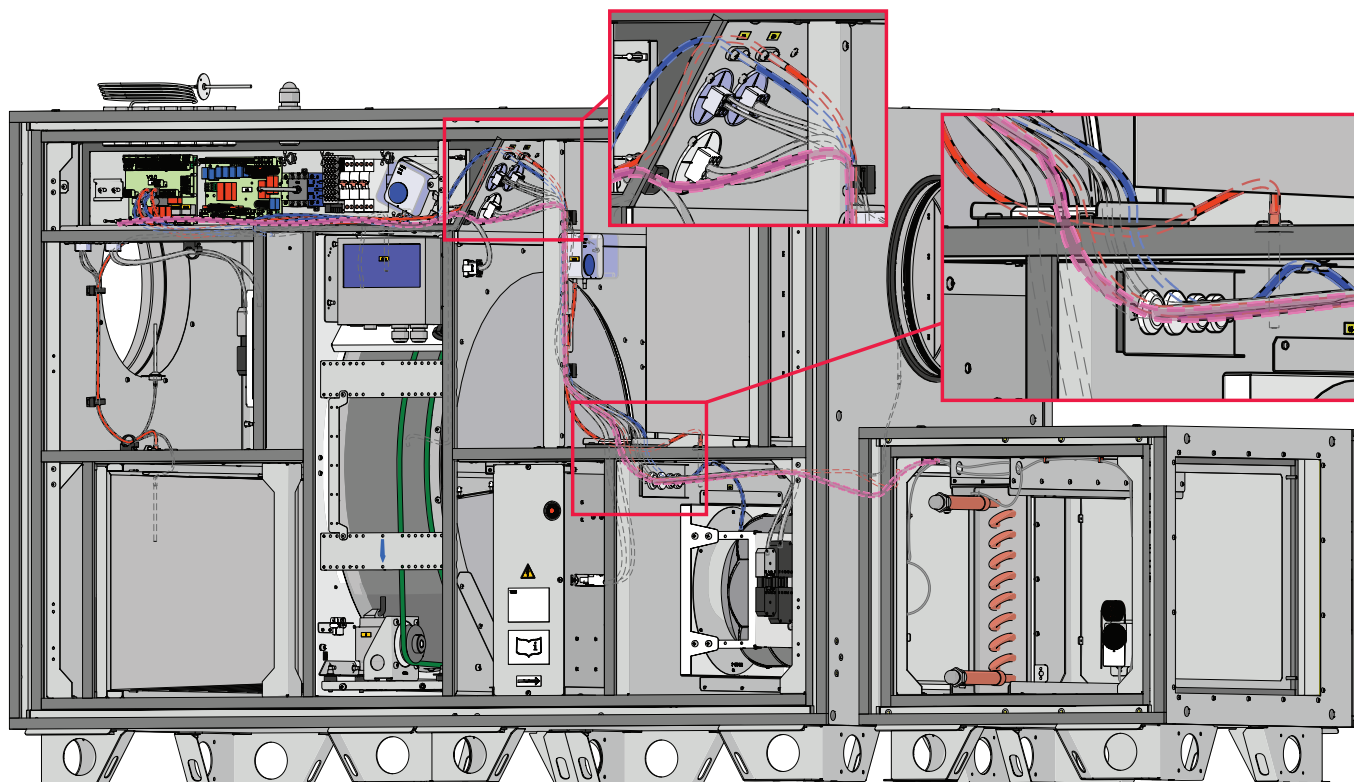

Fig. 4.13.1 External heater/cooler (Comfort Box) cable routing for AmberAir Compact S-R-1000-2000-H

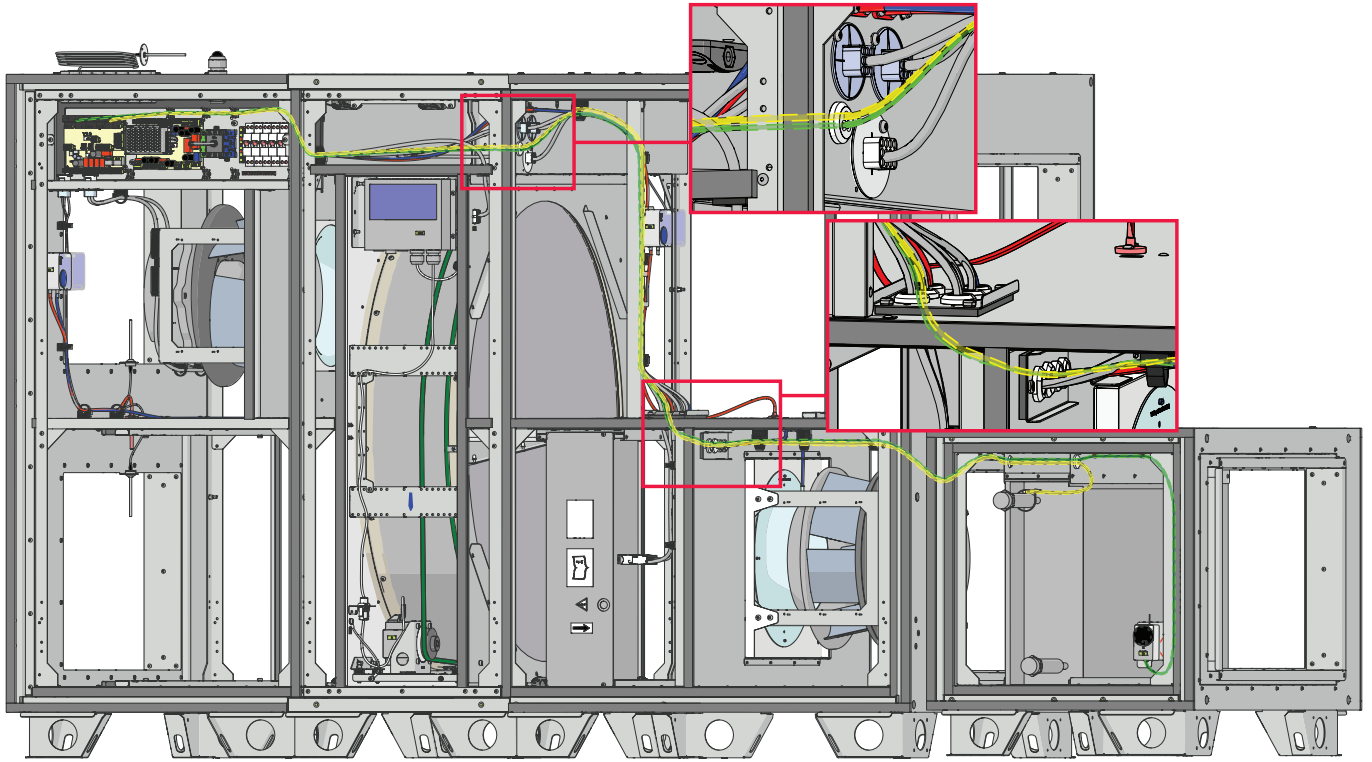

Fig. 4.13.2 External heater/cooler (Comfort Box) cable routing for AmberAir Compact S-R-3000-9000-H

4.14. MOUNTING POSITION OF MB-GATEWAY WEB MODULE

If MB-Gateway module is used, it can be mounted on dedicated DIN rail on control board panel or in the compartment above the rotor (in this case it must be secured using end plates):

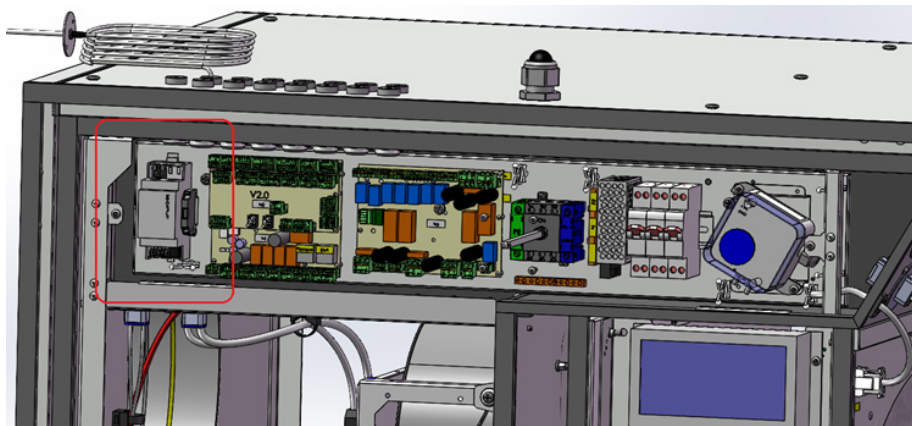

Fig. 4.14.1 AmberAir Compact S-R-1000/1500/2000/7000-H MB-Gateway mounting position

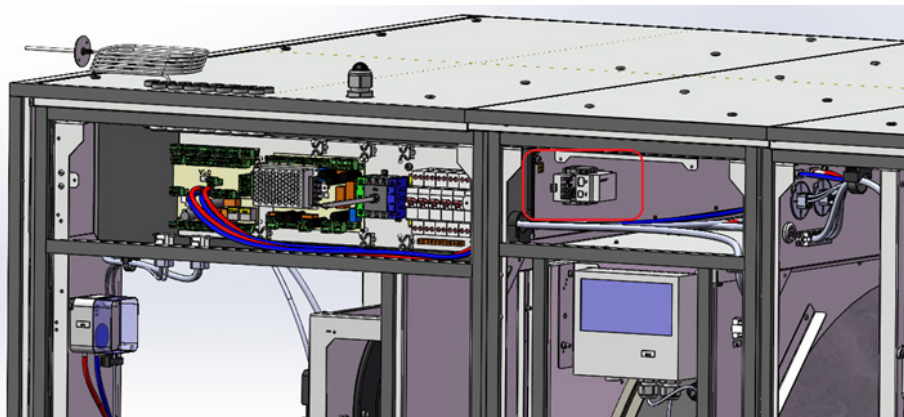





Fig. 4.14.2 AmberAir Compact S-R-3000/4000/5000/9000-H MB-Gateway mounting position

4.15. CONNECTING WATER COILS

Only a specially trained employee may connect the air handling unit to the heating or cooling system. When connecting the coil nozzles to the system, they must be fixed in place with a pipe wrench.

The coil pipes must be connected in such a way that the pipes can be easily accessed during maintenance works. When installing the coil pipes, make sure that the heat carrier supply is completely disconnected. The coil must be filled with a heat transfer medium before starting the air handling unit.

Glycol is used in water heat exchangers. Never pour glycol into wastewater, collect it and dispose of it at recycling centres. Glycol is a very dangerous substance, which may be poisonous even if inhaled in small quantities, avoid contact with the skin and respiratory tract. Keep out of the reach of children. If you are feeling faint, contact your doctor. Avoid breathing glycol vapour indoors. If glycol gets in your eyes, flush them with running water (about 5 minutes). Contact your doctor.

-  **When operating the air handling unit in an environment with a temperature lower than 0 °C, it is necessary to use a water-glycol mixture as the heat carrier or to ensure a return temperature of at least 25 °C.**
-  **The heating mixing point must have a circulating pump and a three-way water mixing valve with a modulating actuator. When using a two-way valve, it is additionally necessary to use a non-return valve to ensure continuous circulation of the heat transfer medium in a small circle. The entire heating mixing point must be installed as close as possible to the coil.**
-  **It is important to keep the air heaters and coolers clean, i.e., to change the filters installed in the air handling unit in time, if the air heater or air cooler becomes dirty it is important to perform their periodic cleaning.**
-  **Take care not to damage the water coil when connecting water pipes to connectors.**

Remove the cable grommet and connect the water pipe to the female threaded connections. Tighten the connection with a spanner. The arrows indicate the water inlet and outlet.

	Water coil		
	Connection	Max diameter pass-through	Type of threads (in/out)
AmberAir Compact S-R/RS-1000-H-CO	DN25 (1")	33,4 mm	Male thread (1")
AmberAir Compact S-R/RS-1500-H-CO	DN25 (1")	33,4 mm	Male thread (1")
AmberAir Compact S-R/RS-2000-H-CO	DN25 (1")	33,4 mm	Male thread (1")
AmberAir Compact S-R/RS-3000-H-CO	DN32 (1-1/4")	42,16 mm	Male thread (1-1/4")
AmberAir Compact S-R/RS-4000-H-CO	DN32 (1-1/4")	42,16 mm	Male thread (1-1/4")
AmberAir Compact S-R/RS-5000-H-CO	DN40 (1-1/2")	48,3 mm	Male thread (1-1/2")
AmberAir Compact S-R/RS-7000-H-CO	DN40 (1-1/2")	48,3 mm	Male thread (1-1/2")
AmberAir Compact S-R/RS-9000-H-CO	DN40 (1-1/2")	48,3 mm	Male thread (1-1/2")

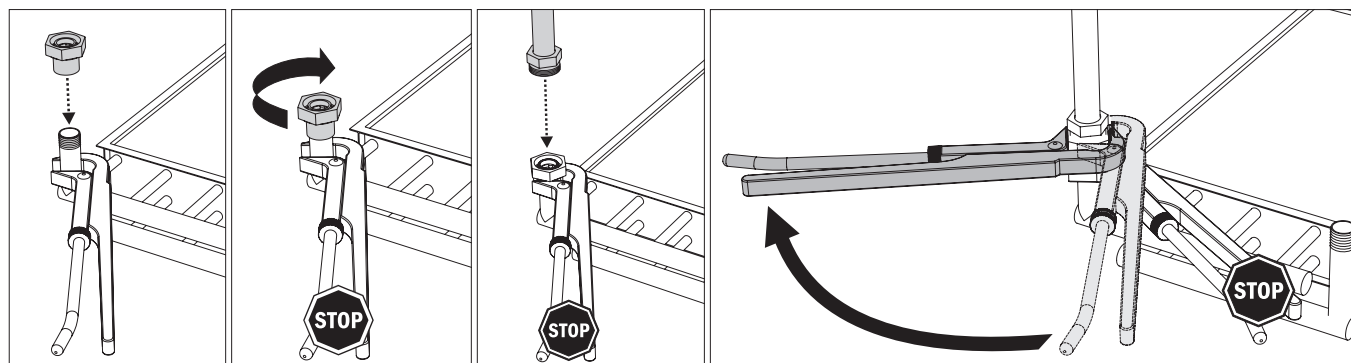

4.16. CONNECTION OF THE UNIT TO THE ELECTRIC NETWORK

- Supply voltage to the unit must be connected by a qualified specialist following the manufacturer's instructions and applicable safety guidelines.
- The unit's power network voltage must correspond to the electro-technical specifications of the unit indicated in the technical decal.
- The unit's voltage, power and other technical specifications are provided in the unit's technical decal (on the unit casing). The unit must be connected to the voltage plug socket of the grounded power network in accordance with the applicable requirements.
- The unit must be earthed according to electrical equipment installation regulations.
- Using extension wires (cables) and power network plug socket distribution devices is not allowed.
- Before it is connected to the power network, the unit must be carefully checked for any damage (operation, control, and measurement nodes) made during transportation.
- Prior to carrying out any ventilation unit installation and connection works (before the unit is commissioned), the unit must be disconnected from the power network.
- Remove the control box cover (see section "CONTROL BOARD MAINTENANCE").
- Remove the cable gland plug and route the power supply cable from the outside of the unit to the inside of the control box through the plastic cable gland on the upper unit's panel.
- Connect securely power supply cable wires to the corresponding unit's safety switch Q1 terminals inside of the control box. Connection depends on the electro-technical specifications of the exact unit.

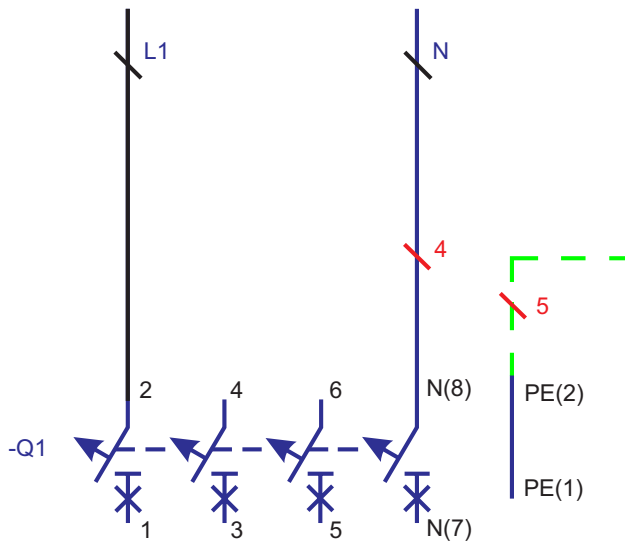

User side

Fig. 4.16.1 Units with 1N~ 230V power supply

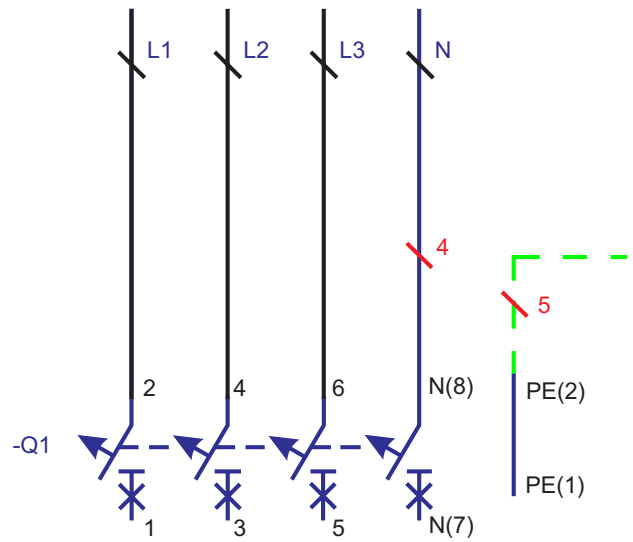

User side

Fig. 4.16.2 Units with 3N~ 400V power supply

- After installation of the ventilation unit, the power network plug socket must be accessible at any time. When the unit is connected to the power network, disconnection from it is performed through the safety switch (by disconnecting phase poles and neutral).
- The power cable can be replaced only by a qualified technician, after the evaluation of the rated power and current.



The manufacturer does not assume any liability for personal injuries and property damage due to non-conformance with the provided instructions.

4.17. SYSTEM PROTECTION

MCB controller and its modules are equipped with integrated protection devices (fuses). Fuse F7 with value 10A provides rotor motor protection against short circuit. Values of the other fuses can be found in MCB technical manual. Additionally, the control board of the unit is equipped with circuit breakers which can be found in electric wiring diagrams.

It is recommended to use the unit with an external electrical protection device.

AmberAir Compact S-R/RS	Recommended fuse (recommended short circuit breaker)	AmberAir Compact S-R/RS	Recommended fuse (recommended short circuit breaker)
1000-H-E-C1	16 A	4000-H-E-C1	32 A
1000-H-E2-C1	16 A	4000-H-E2-C1	40 A
1000-H-CO/DX/Empty-C1	10 A	4000-H-CO/DX/Empty-C1	10 A
1500-H-E-C1	16 A	5000-H-E-C1	32 A
1500-H-E2-C1	25 A	5000-H-E2-C1	63 A
1500-H-CO/DX/Empty-C1	10 A	5000-H-CO/DX/Empty-C1	10 A
2000-H-E-C1	16 A	7000-H-E-C1	63 A
2000-H-E2-C1	25 A	7000-H-E2-C1	63 A
2000-H-CO/DX/Empty-C1	10 A	7000-H-CO/DX/Empty-C1	16 A
3000-H-E-C1	25 A	9000-H-E-C1	63 A
3000-H-E2-C1	40 A	9000-H-E2-C1	100 A
3000-H-CO/DX/Empty-C1	20 A	9000-H-CO/DX/Empty-C1	20 A

AmberAir Compact S-R-1500-H-E-R-C1 AlZn

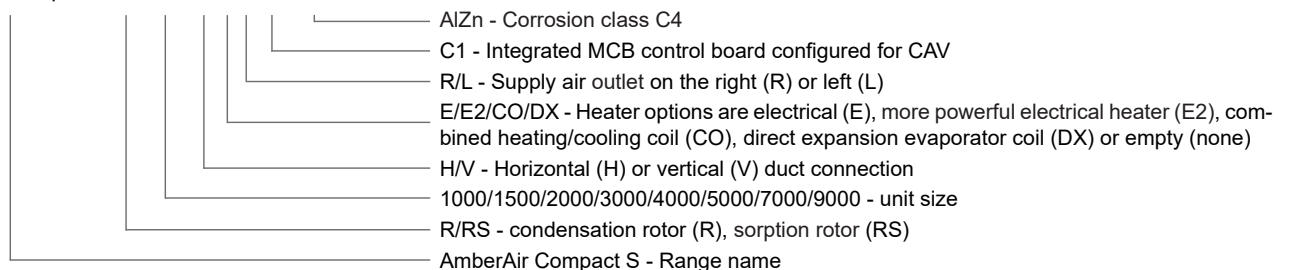

Recommended values are provided only for units with factory-integrated components. When additional accessories are connected to the unit, the external protection device value must be selected accordingly.



To ensure safe maintenance of the unit, it is necessary to turn off the main switch and/or external protection device.

4.18. EXTERNAL DEVICE CONNECTION

All electrical connections must be connected by a qualified specialist following the manufacturer's instructions and applicable safety guidelines. All external devices must be connected to the unit in the control box section. To access the control box section, open the unit's cover and remove the control box section cover (more details can be found in the "**CONTROL BOARD MAINTENANCE**" section). Above the control box, there are cable glands integrated into the unit's upper panel intended for external device cables and wires. Puncture the cable gland or remove the cable gland plug before routing the cable or wires. Make sure all cables and wires are secured and the inside of the control box is sealed. Communication cables of external devices must be routed as far as possible from the power cables.

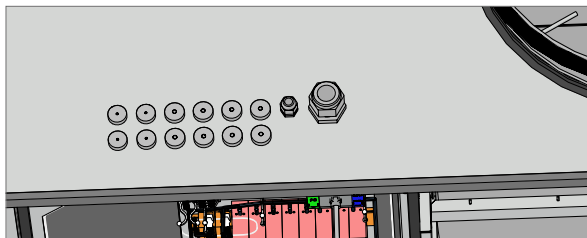
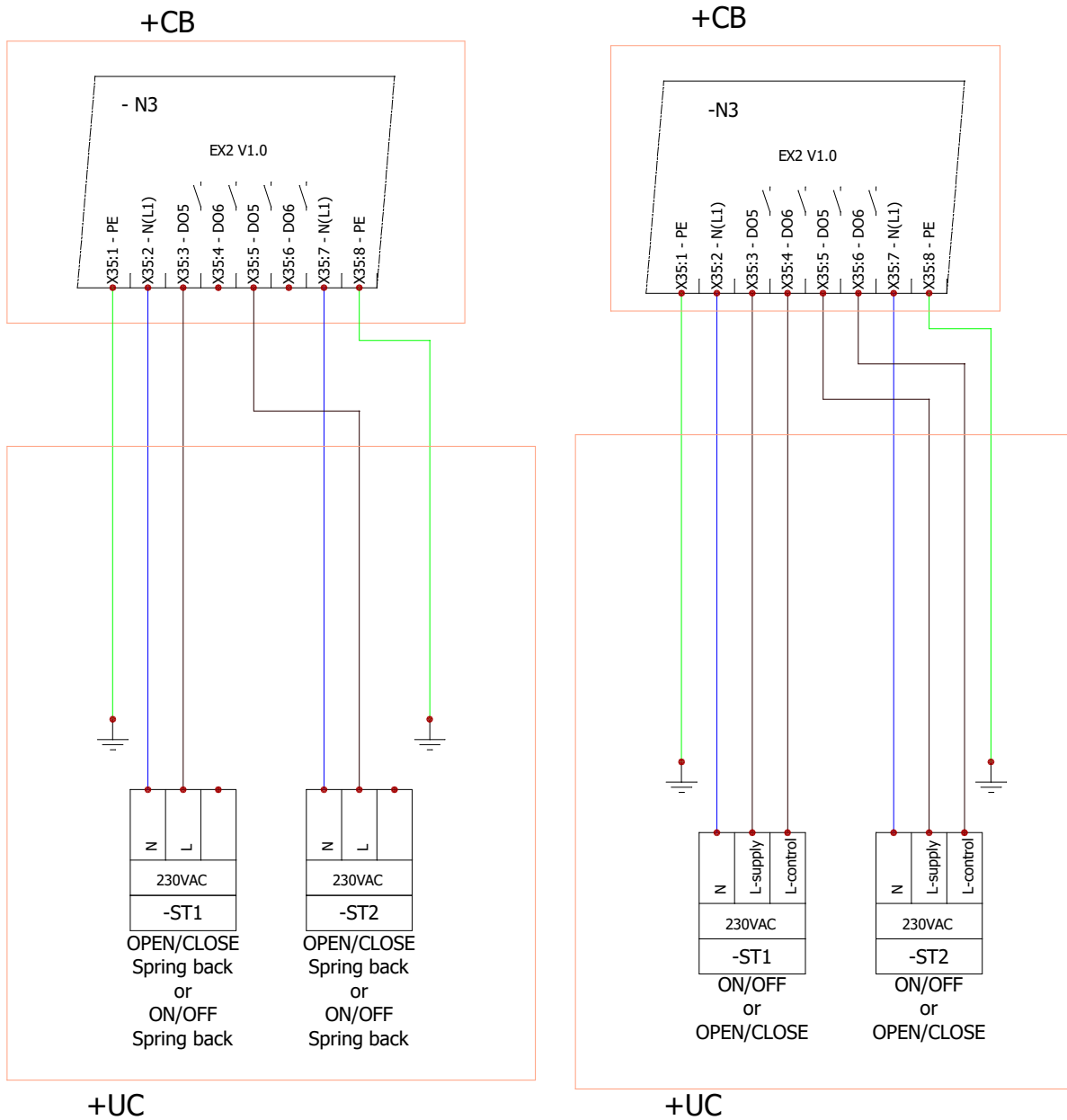

Fig. 4.18.1 Cable glands

4.19. CONNECTION OF ACCESSORIES

4.19.1. OUTDOOR AND EXHAUST AIR DAMPERS

Product AmberAir Compact can be equipped with outdoor air and exhaust air dampers. Dampers can be controlled with Open/Close, On/Off or Spring-back actuators ST1 and ST2. Upon activation of EX2 DO5 the dampers shall open. Upon activation of EX2 DO6 the dampers with Open/Close or On/Off actuators shall close. Dampers with Spring-back actuators close when EX2 DO5 is deactivated.



4.19.2. FIRE AND FIREPLACE SAFETY (SAFETY INPUTS, DAMPERS)

Product AmberAir Compact can be equipped with fire dampers for extract and supply air. Dampers are controlled by Spring-return actuators (A1, A2). Upon activation of signals EX2 DO1 and EX2 DO2 the dampers shall open. When EX2 DO1/DO2 is deactivated, the dampers shall close. Fire dampers must be equipped with damper position switches. When the dampers completely close, the switches K6/K8 should be activated. When the dampers are completely open, switches K5/K7 should be activated. MCB controller can be configured to operate with NO or NC switches. For fire safety function it is available to connect the external switch FA (i.e., smoke detector) to MCB DI4 input. By default, unit's controller is configured to operate with NC fire safety switch. As long as the fire protection device is not connected to the ventilation unit, on an input there must be a factory-installed jumper.

For the fireplace protection function, it is also possible to connect external fireplace protection switch FAA to MCB DI8 input. By default, the unit's controller is configured to operate with NO fireplace protection switch and it can be reconfigured.

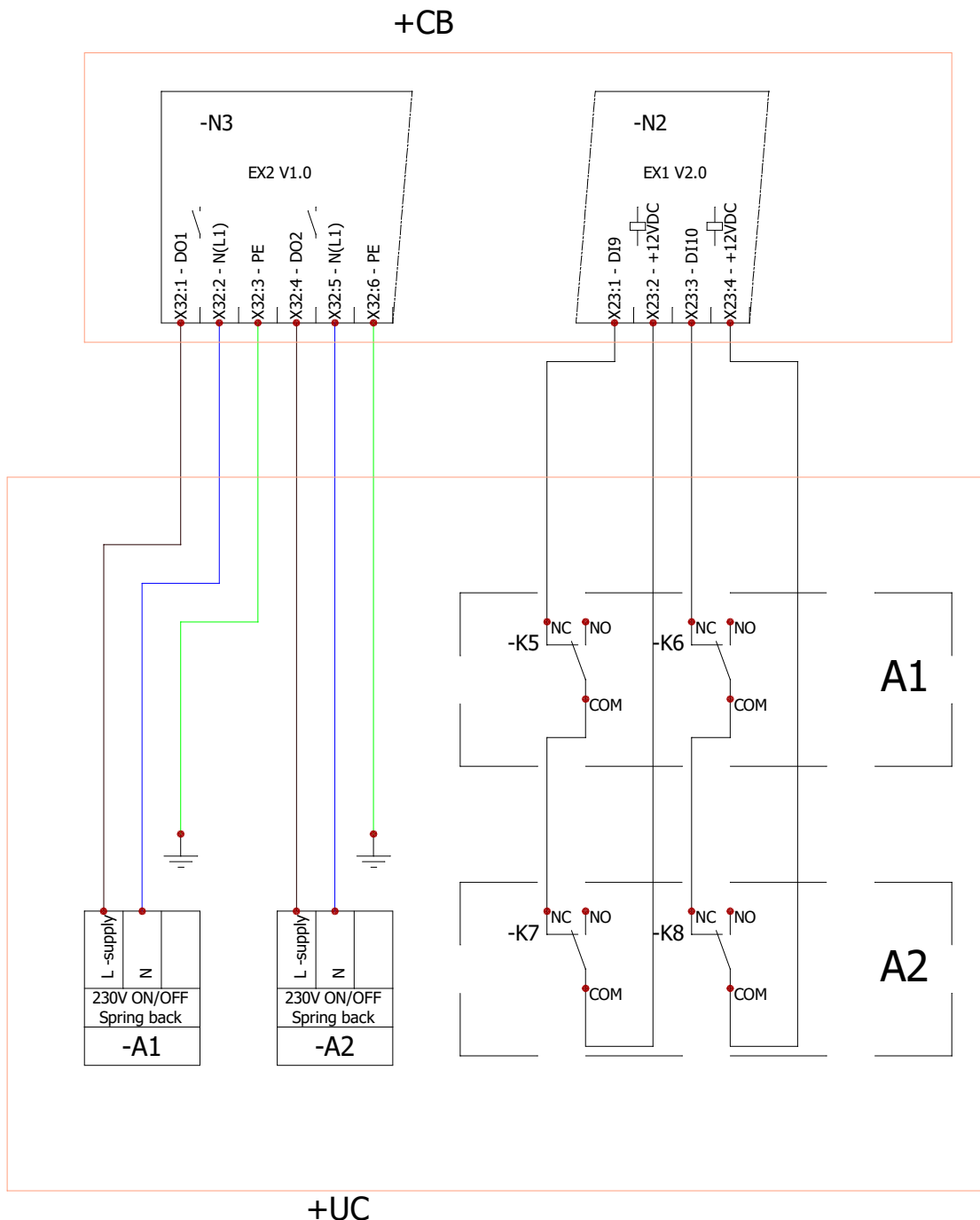

Fig. 4.19.2.1 Fire dampers and position switches connection

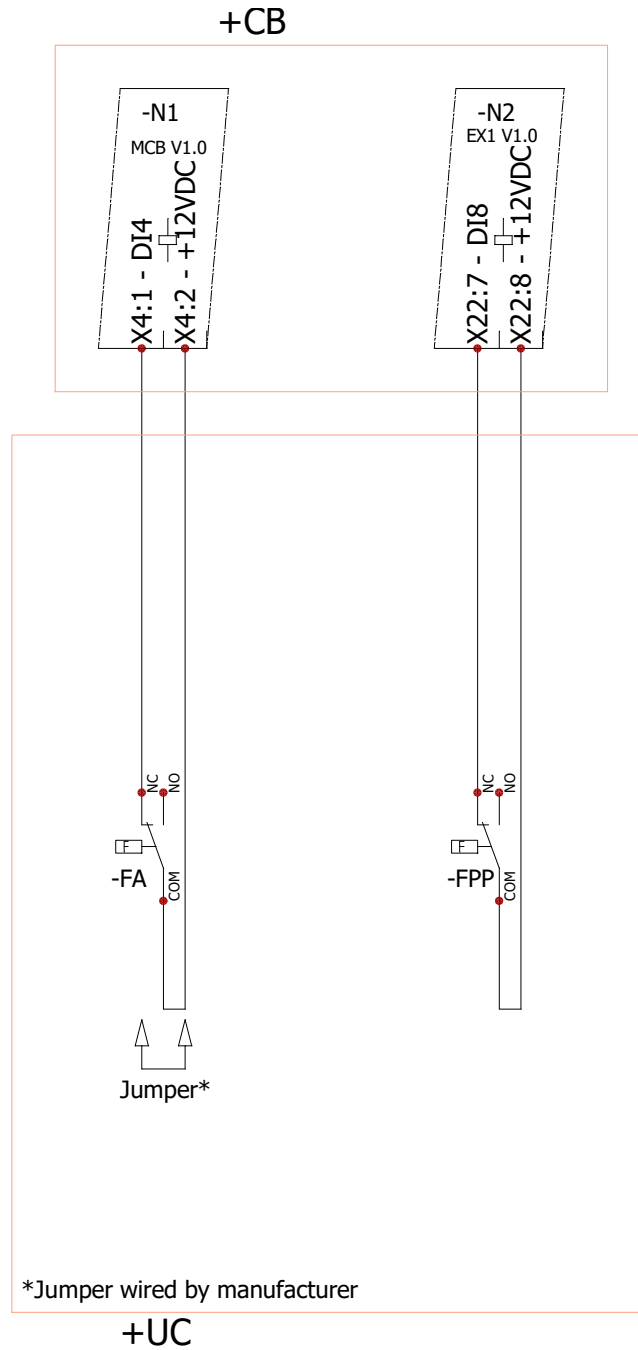

Fig. 4.19.2.2 Fire and fireplace safety switch connection

4.19.3. EXTERNAL HEATER, COOLER (COIL2)

For AmberAir Compact units with integrated electrical heater or without integrated coil, it is possible to connect an external DX cooler and an external combined heating/cooling coil.

For units with integrated combined heating/cooling coil, it is possible to connect an external DX cooler and an external water heater.

For units with integrated DX cooling coil, it is possible to connect an external water heater and an external combined heating/cooling coil.

These components are controlled with DO and 0-10V outputs. When digital output (EX2 DO3 for combined heating/cooling coil; EX2 DO8 for water heater; EX2 DO10 for DX cooler) activates, the external device (DX cooler or water circulation pump) should start. When digital output deactivates, the external device should stop.

Analog output (MCB AO3 for water heater; EX1 AO2 for DX cooler; EX1 AO3 for combined heating/cooling coil) - DX cooler control or water valve actuator control signal. It sets the needed value of heating/cooling of the external device. Combined heating/cooling coil water return temperature sensor connects to EX1 AI4. The coil mode (heating/cooling) can be switched with a reverse thermostat (NC/NO) which connects to MCB DI1. Water heater return water temperature sensor connects to MCB AI7. The combined heating/cooling coil and the water heater additionally use a protection thermostat (NC) which connects to MCB DI2.

When the combined heating/cooling coil and another heater (electrical or water) are used together in the same control system, the combined coil can only work in cooling mode and the protection thermostat can only be used by the water heater. The EX1 DI5 is used for DX cooler protection (NO/NC input mode can be configured). The heating/cooling reverse input connects to EX2 DO9 (NO-cooling; NC-heating).

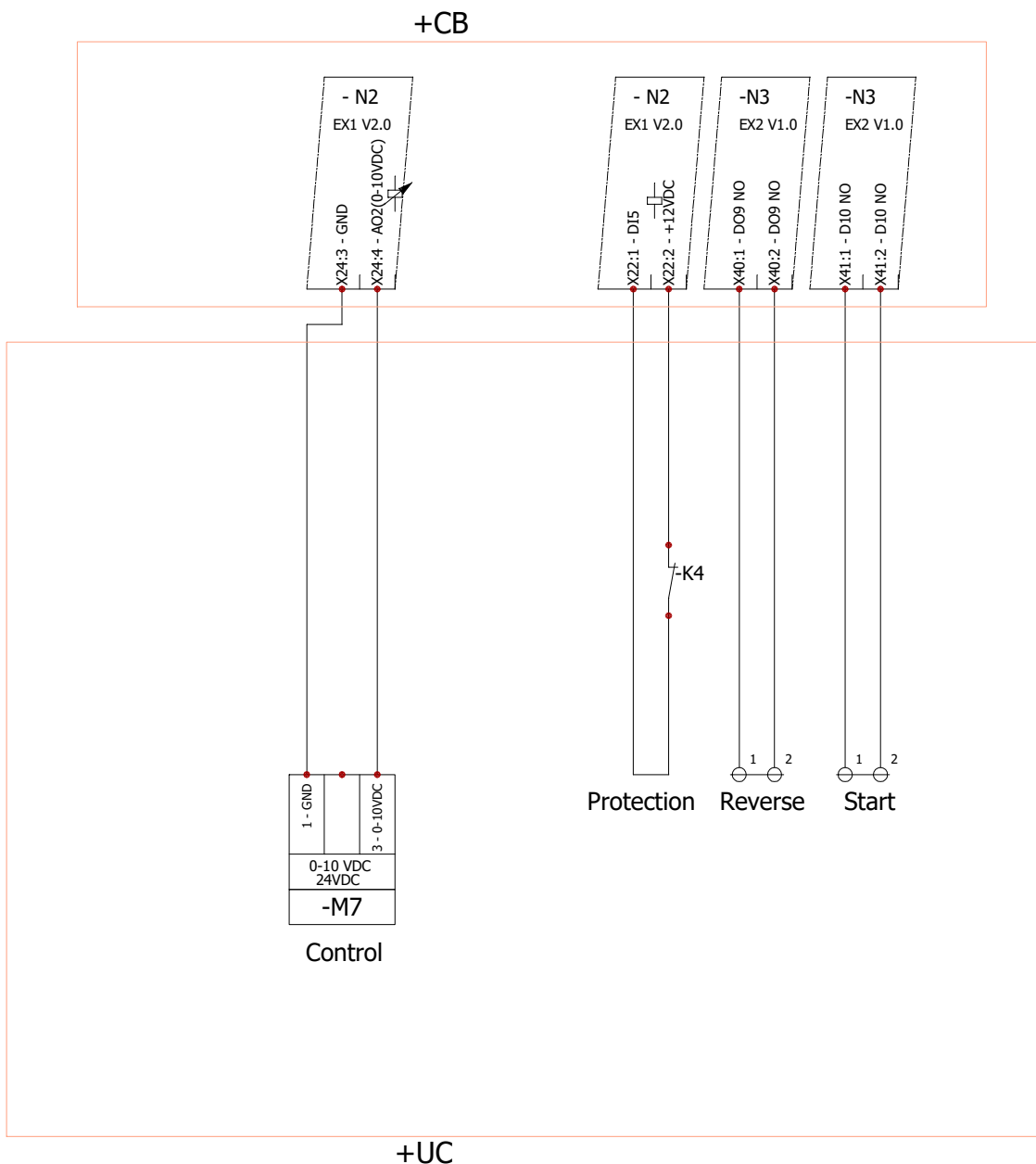
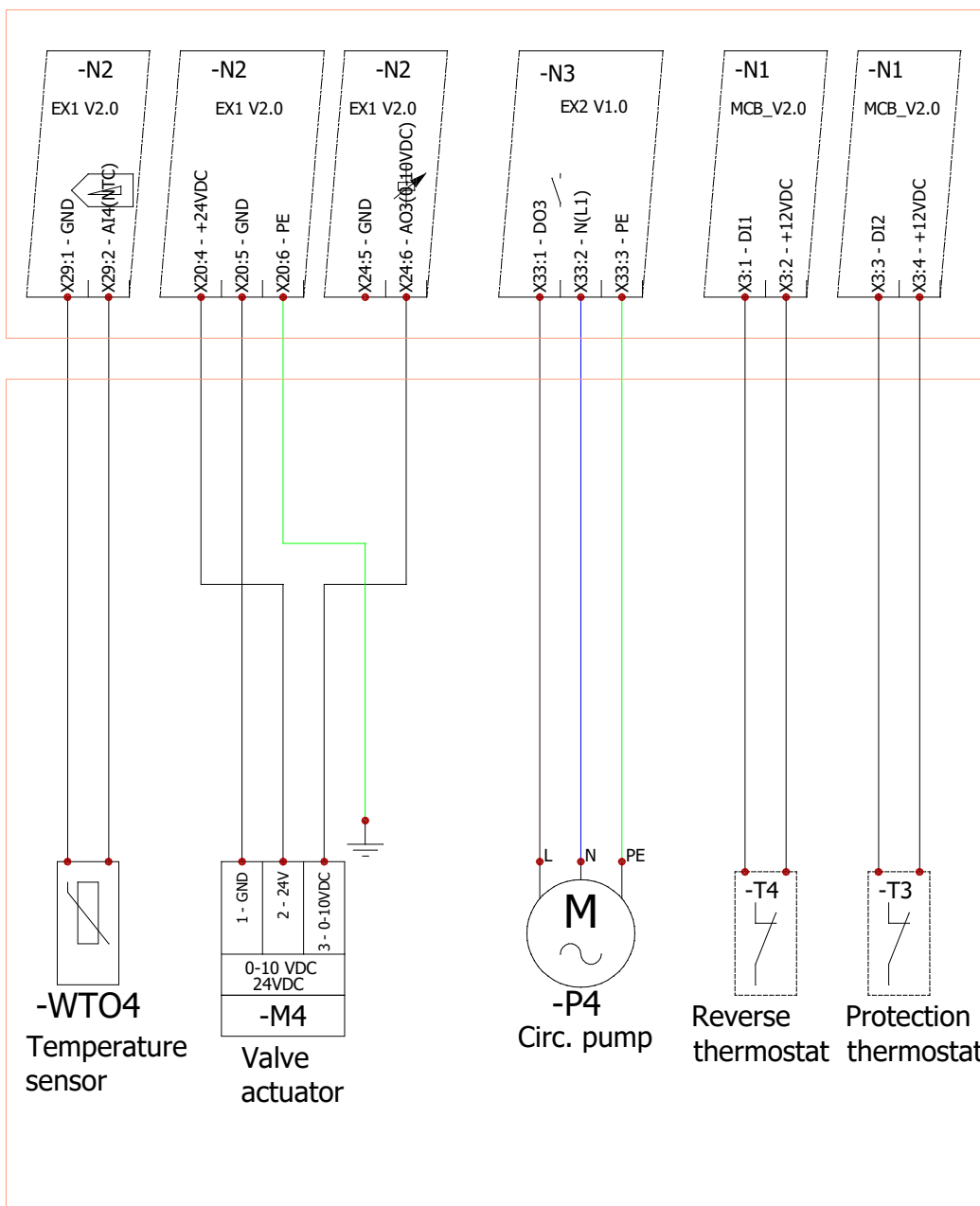

Fig. 4.19.3.1 External DX cooler connection

+CB



+UC

Fig. 4.19.3.2 External combined heating/cooling coil connection

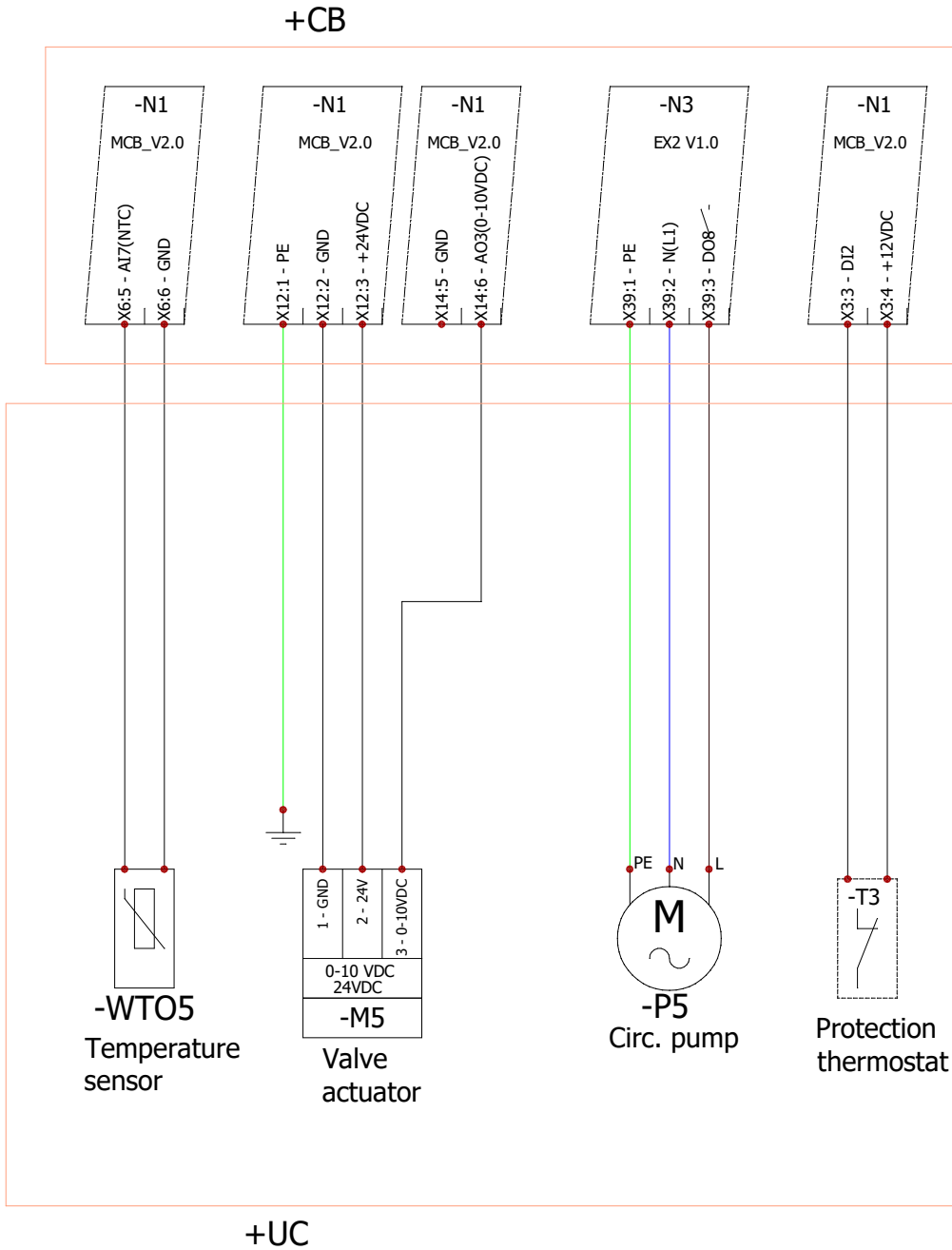

Fig. 4.19.3.3 External water heater connection

4.19.4. EXTERNAL PREHEATER (COIL3)

For AmberAir Compact units it is available to connect electrical or water preheater. These components are controlled with DO and 0-10V outputs. When digital output EX2 DO11 activates, the external device (electrical preheater or water circulation pump) should start. When digital output deactivates, the external device should stop. Analog output EX1 AO1 electrical preheater or water valve actuator control signal. It sets the needed value for heating the external device. The electrical preheater automatic protection (AT1) thermostat connects to EX1 DI1 input. Its manual protection (RT1) thermostat connects to EX1 DI2 input. The water preheater return water temperature sensor connects to EX1 AI5 input. The water preheater return water temperature sensor connects to EX1 AI5 input.

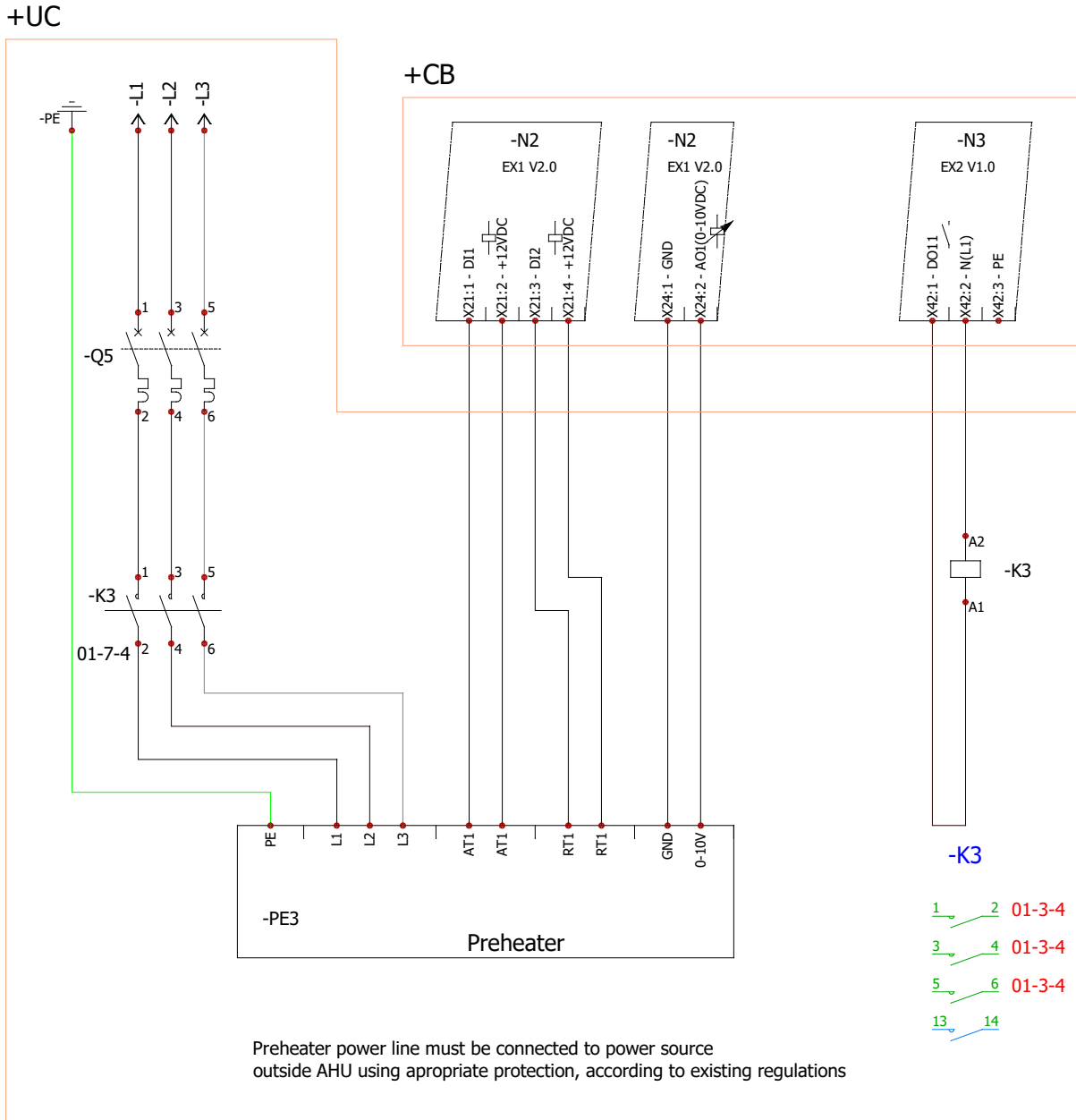

Fig. 4.19.4.1 External electrical preheater connection

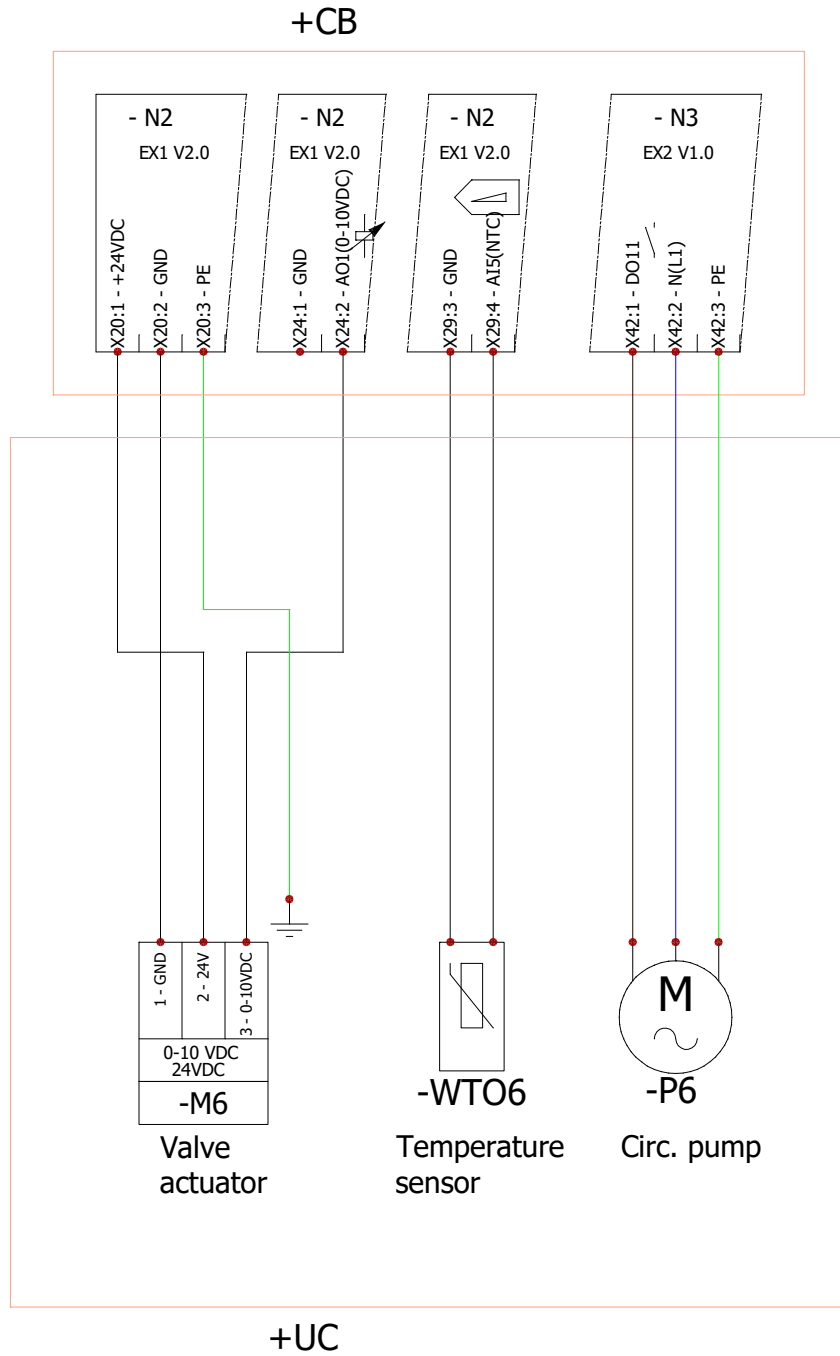
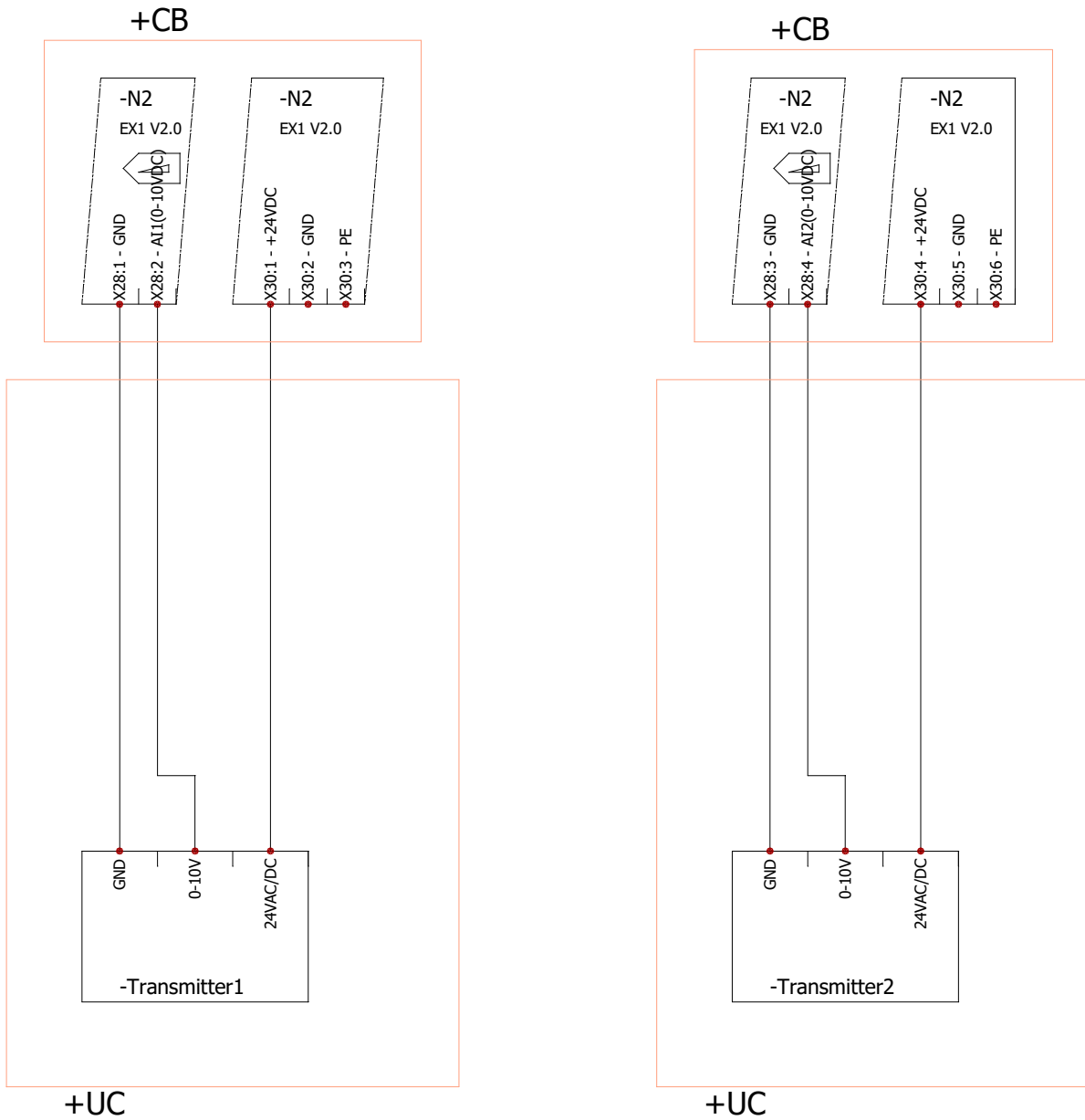

Fig. 4.19.4.2 External water preheater connection

4.19.5. AIR QUALITY SENSORS WITH ANALOG OUTPUT

Two air quality sensors with 0-10VDC output may be connected to the AmberAir Compact unit. These sensors may be installed in the extract air duct or room and can measure extract air RH or extract air CO₂. EX1 AI1/AI2 inputs are dedicated to outputs of 0-10VDC air quality sensors.



4.19.6. INTEGRATED DX COOLER OR COMBINED HEATING/COOLING COIL

The water circulation pump, valve actuator and reverse thermostat can only be connected to the AmberAir Compact units that are designed to operate with combined heating/cooling coil.

The position of the valve actuator with 24VDC power input is controlled by the 0-10VDC signal (EX1 AO3). The circulation pump is controlled by the start/stop (digital output) signal. When digital output (EX2 DO3) is activated the circulation pump should start. When the digital output is deactivated, the circulation pump should stop.

For the units with the integrated combined heating/cooling coil, the coil mode (heating/cooling) can be switched with a reverse thermostat (NC/NO) which connects to MCB DI1.

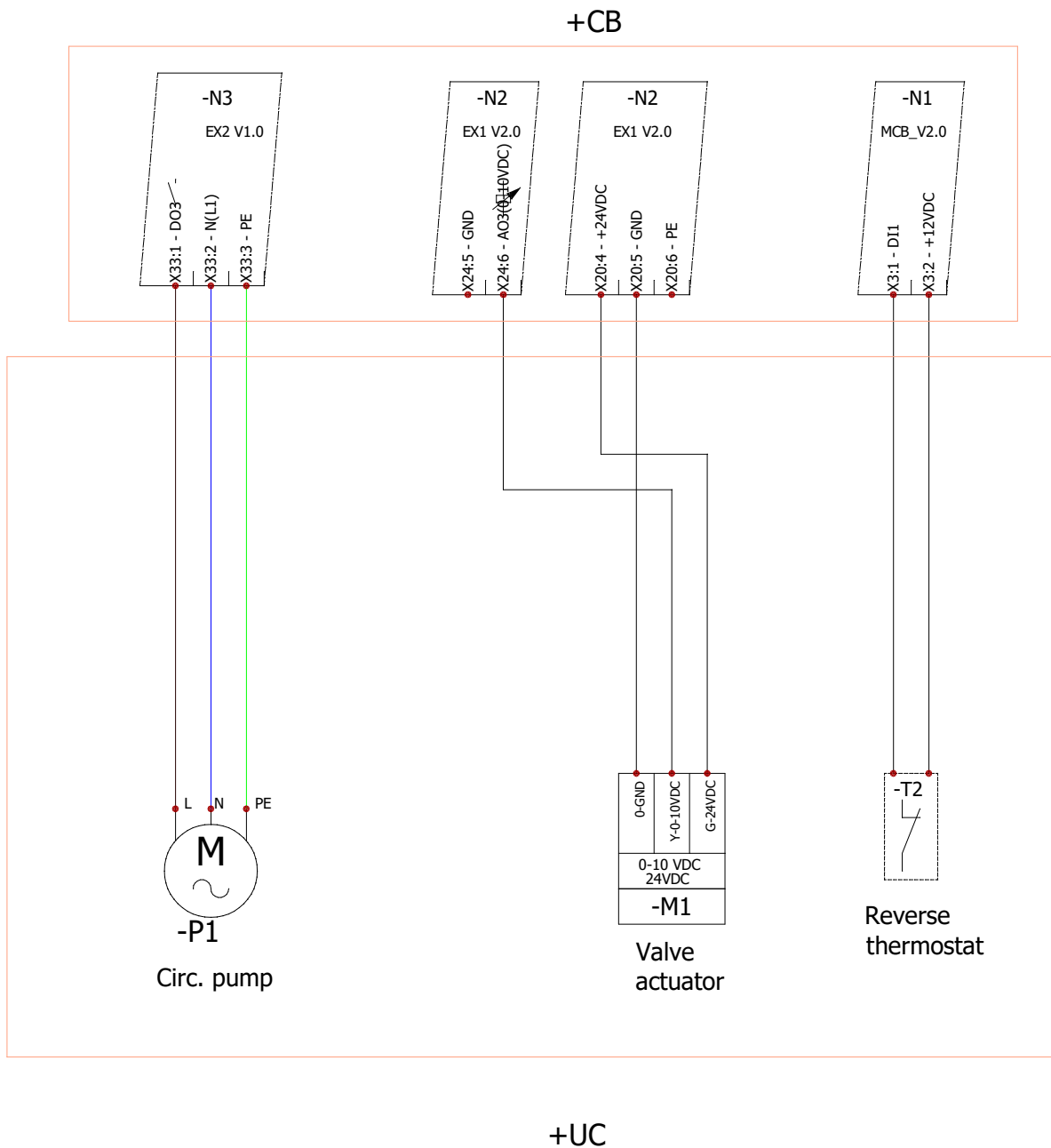

Fig. 4.19.6.1 Internal combined heating/cooling coil accessories connection

Integrated DX cooler coil control signals connect same as external DX cooler control signals (see section “EXTERNAL HEATER, COOLER (COIL2)”).

4.19.7. EXTERNAL INDICATION OUTPUTS AND CUSTOM SWITCHES

Two 24VDC external indication outputs can be connected to the AmberAir Compact unit. One output (START) is to indicate that the unit is operating. Another output (STOP) is to indicate that the unit encountered a problem and stopped operating. EX1 IND_1/IND_2 outputs are dedicated for indication.

Two external switches can also be connected to the AmberAir Compact unit. One switch is to change working mode of the unit (by default Standby). Another switch is to change fan speed (by default 100%) EX1 DI3/DI4 inputs are dedicated to external switches.

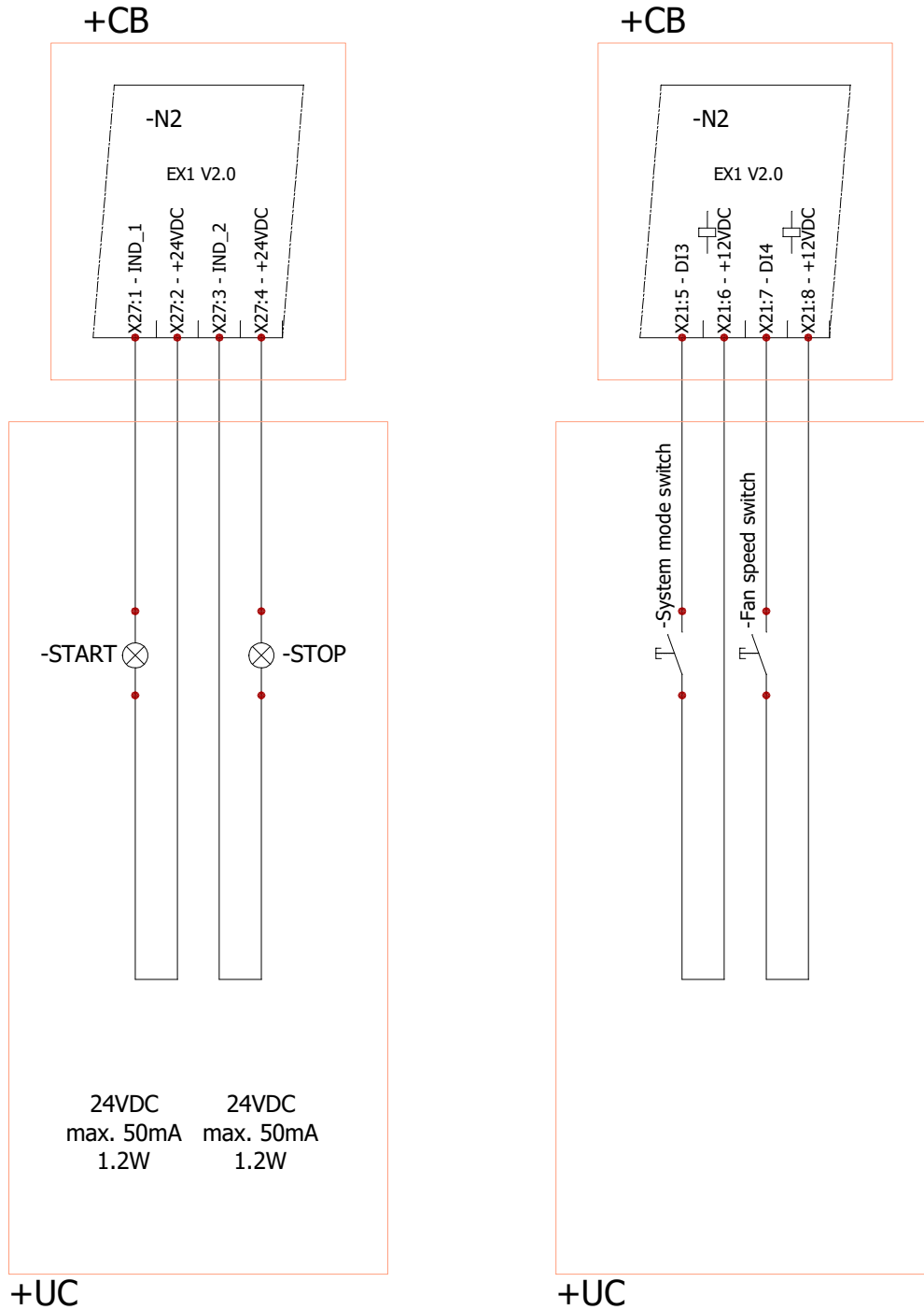

5. COMMISSIONING

5.1. GENERAL

- The unit may be commissioned only by properly educated and trained personnel and in compliance with all the relevant safety regulations and standards.
- Prior to putting the unit into operation for the first time, it is necessary to complete each previous step of the installation instructions.
- Prior to putting the unit into operation, it is necessary to go through each step of the following paragraphs and to record these actions in the appropriate protocols, which will be filed with the operational documentation.
- When checking the individual components of the unit, it is possible to use the following paragraphs containing step-by-step instructions, which have been created as protocols and which can serve as a useful tool for commissioning.

5.2. OPERATIONS PRIOR TO THE FIRST START

The fans must not run when air dampers are closed. It is necessary to avoid pressure shocks arising during testing of the functionality of fire dampers or other dampers by closing the dampers for a short period of time. The first test run of the unit should not exceed 30 minutes. After that, it is necessary to thoroughly check all its sections again. After initial commissioning, it is necessary to clean all the input filters or replace them with new ones.

Name of service technician:

Service company name:

Tel. No.:

Date:

Signature:

DESCRIPTION OF SERVICING OPERATION	YES	NO	COMMENT
Check each section for external or internal damage.			
Check the total tightness of the unit – visually (the door, service panels, fixed panels, etc.).			
Check the mounting of the roof on outdoor units acc. to installation instructions.			
Check for foreign objects, debris, or tools inside the unit. If necessary, clean the inside of the unit			
Check the seal between the filter elements according to the mounting instructions.			
Check the cleanness and integrity of the filter elements.			
Check whether all air filters are installed.			
Check the setting of the pressure differential switch.			
Check the impeller for free rotation.			
Check the cleanness of the impeller and the chamber.			
Check the fan operation for excessive vibrations.			
Check the connection of pressure probes for measuring differential pressure.			
Check the heat exchanger cleanness and integrity of the heat-transfer surface.			
Check that the duct system is fully installed.			
Check that the valves are installed and open.			
Check that the water coils are properly connected.			
Check that the condensate drain is properly installed and filled with water.			
Check the tightness of the connections of the working fluid/mixing device to the water coil.			
Check the water coil for de-aeration.			
Check the water heater connection in counter flow – according to the mounting instructions.			
Check the duct system for unnecessary obstructions, such as completely closed diffusers and control dampers, or for clogged outdoor air intake grilles.			
Check that all components are fastened.			
Check whether the unit's seals and sealing surfaces are not damaged.			
Check whether the unit's cables, wires and connectors are properly connected to external components.			
Check whether cables and wires connected to terminal blocks comply with the existing wiring diagrams.			
Check whether cables and wires correspond to all applicable safety and functional requirements, diameters, etc.			
Check whether electrical earthing and protection systems are properly installed.			

DESCRIPTION OF SERVICING OPERATION	YES	NO	COMMENT
Other operation:			

5.3. CHANGE OF FANS CONTROL TYPE

AmberAir Compact units come from the factory configured to have fan speed control by constant air flow. Units can be converted to control fans by constant air pressure. Converting to constant air pressure control requires additional accessory (conversion kit).

Converting to constant air pressure control type:

- Disconnect the unit from the power source and wait until any fan rotation stops.
- Open the unit door and remove the control board cover (see **"CONTROL BOARD MAINTENANCE"** section).
- Inside control board section of the unit, disconnect U3-, U3+, U4-, U4+ pressure hoses from N2 (MCB EX1) module U3 and U4 sensor adapters.

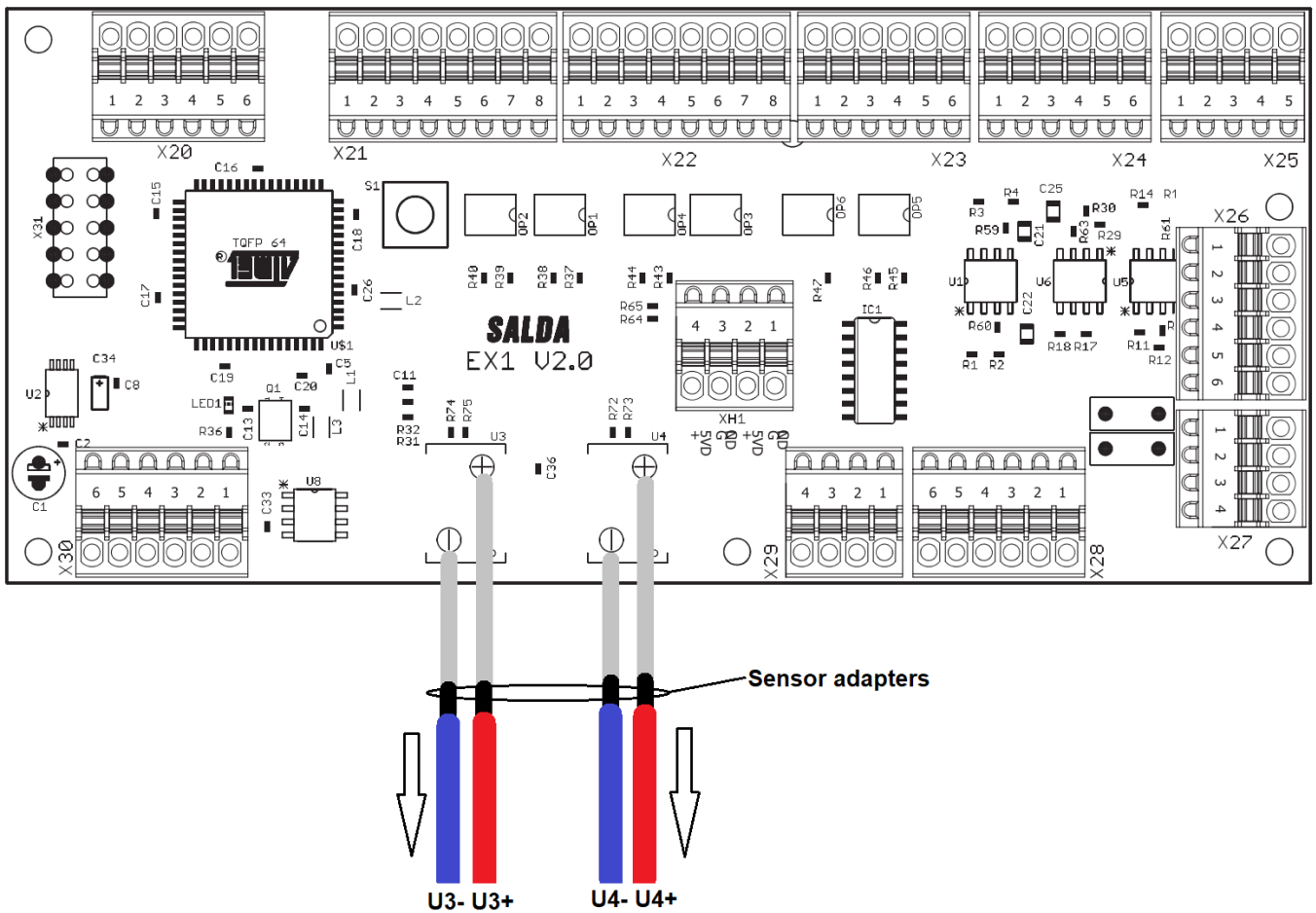

- Connect new hoses to the sensor adapters. Route hoses to the outside of the unit through the upper grommets and mount them as shown below.

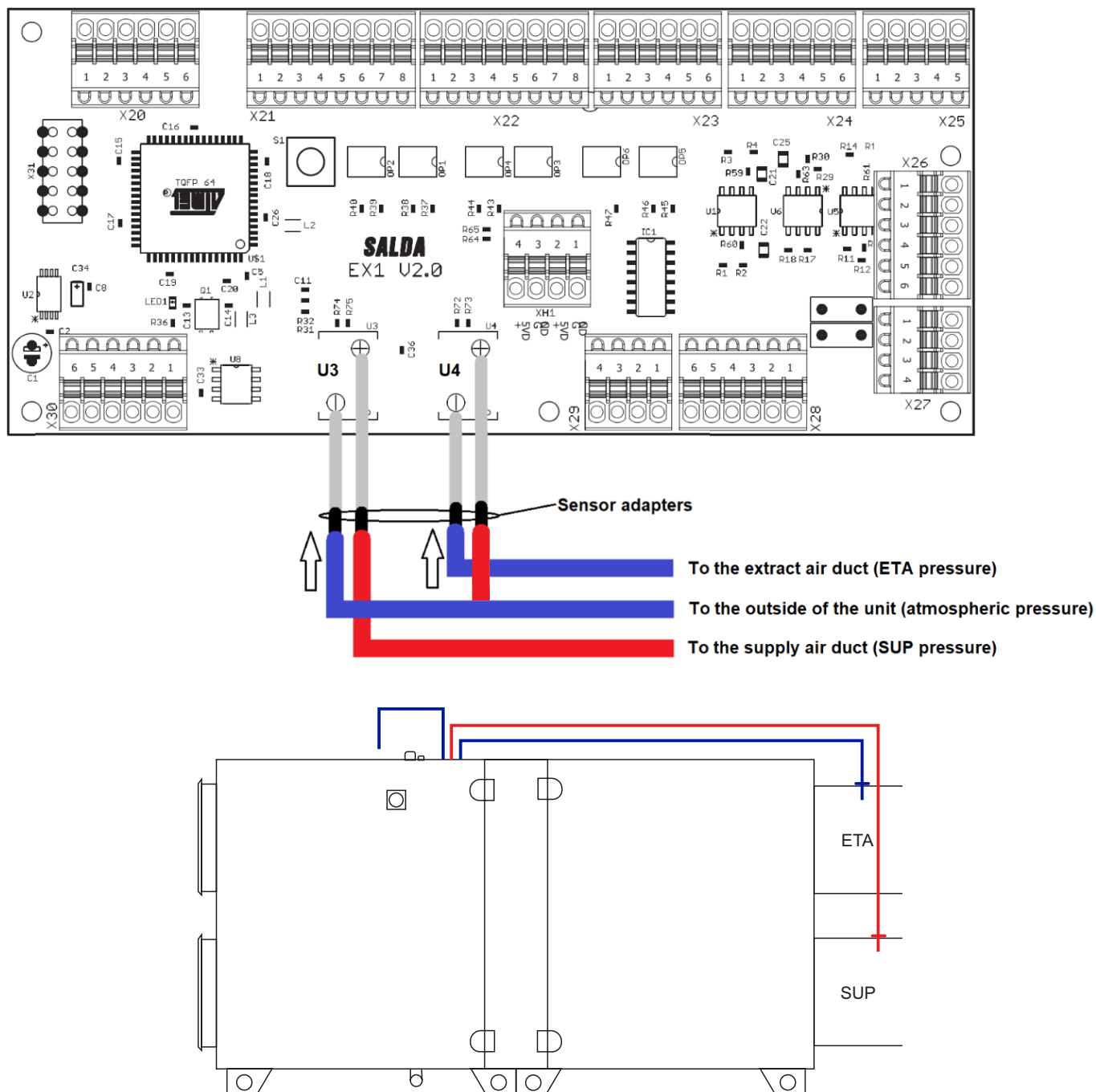

Fig. 5.3.1 Horizontal Right units



For left side units SUP and ETA ducts are located on the opposite side.

After installation of the pressure hoses, the controller of the unit must be configured for controlling fan speed by constant air pressure. Configuration can be implemented using the web interface, SALDA AIR mobile application or ST-SA-Control remote panel.

- Go to the unit's controller configuration parameters (see section **"ACCESS OF CONFIGURATION PARAMETERS"**).
- In the **SERVICE** menu select **FANS**.
- Set the fan's control type as **PRESSURE** and the maximum air flow pressure value.
- In the **SERVICE** menu select **SAVE CHANGES/SAVE SETTINGS** and **RESTART (AHU)**.
- To change default pressure setpoint values for each operation mode, in the **ADJUSTER** menu select **AIR FLOWS ADJUSTING** and set preferred setpoints. Select **SAVE CHANGES/SAVE SETTINGS**.

Converting to percentage control type:

- Go to the unit's controller configuration parameters (see section **"ACCESS OF CONFIGURATION PARAMETERS"**).
- In the **SERVICE** menu select **FANS**.
- Set the fan's control type as **PERCENT**.
- In the **SERVICE** menu select **SAVE CHANGES/SAVE SETTINGS** and **RESTART (AHU)**.
- To change default pressure setpoint values for each operation mode, in the **ADJUSTER** menu select **AIR FLOWS ADJUSTING** and set preferred setpoints. Select **SAVE CHANGES/SAVE SETTINGS**.

5.4. PRESSURE SWITCH SETTING

Pressure relays indicate pollution of the filters. Standard settings for filter pollution are 150Pa but need to be changed according to the unit's selection data.

Setting the value of the pressure switch

To set the pressure switch activation value follow the steps indicated below:

- Unscrew the pressure switch fixing screws.
- Remove the pressure switch cover.
- Set the switch activation value of differential pressure by rotating blue panel with pressure values and aligning the value to the red mark.
- To reassemble, follow steps in reverse order.

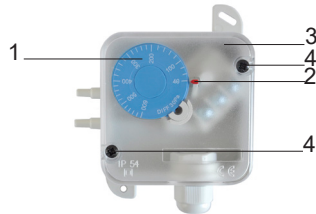

1 - Panel with pressure values; 2 - Mark; 3 - Cover; 4 - Fixing screws.

5.5. ACCESSORIES SETUP

Some accessories or functions of the connected external components must be additionally configured to work properly in the Air Handling unit's system. Configuration can be implemented via the web interface, SALDA AIR mobile application or ST-SA-Control remote panel. Mobile application can be downloaded from the Google Play Store (for Android devices) and Apple App Store (for iOS devices).

5.5.1. ACCESS OF CONFIGURATION PARAMETERS

To access configuration parameters using the web interface follow the steps below (additional device required: MB-Gateway):

- Configure the MB-Gateway device to your local network structure (if needed) and connect it to the AmberAir Compact unit as well as to your local network. More information is provided in the MB-Gateway launch guide.
- In the web browser of the device on the same local network open <http://salda.it/mcb/control/service.htm>.
- Enter MB-Gateway IP, LOGIN (by default – admin), PASS (by default – admin), unit ID (by default - 1), and press SET.



- To access unit configuration parameters enter the service user menu password (by default – 4444) and press the KEY symbol.



To access configuration parameters with ST-SA-Control remote panel follow the steps below:

- Connect ST-SA-Control to the AmberAir Compact unit, turn on the unit and wait for the panel to load up. Access your unit automatically or manually (adjuster password by default – 1111). More information is provided in the ST-SA-CONTROL manual.
- To access unit configuration parameters in the main window select MENU > SERVICE. Enter the password (by default – 4444) and press OK.

To access configuration parameters with SALDA AIR mobile app follow the steps below (additional devices required: MB-Gateway, WIFI router):

- Configure the MB-Gateway device to your local network structure (if needed) and connect it to the AmberAir Compact unit as well as to your local network with WIFI access. More information is provided in the MB-Gateway launch guide.
- Download and install the SALDA AIR application on a smartphone or tablet.

SALDA AIR



- Turn on the unit
- Connect to your WIFI access point.
- Start the SALDA AIR application and access your unit automatically or manually (units SLAVE ID by default – 1; MB-Gateway PORT and IP depends on its configuration; adjuster password by default – 1111).
- To access unit configuration parameters in the main window select MENU  > SERVICE. Enter the password (by default – 4444) and press OK.



More information about operating a particular control environment can be found in its provided documentation.

5.5.2. AIRFLOW AND FIRE DAMPERS

- In the SERVICE menu select DAMPERS.
- Set supply and extract air damper type and opening time.
- Set the fire damper type and other available parameters.
- In the SERVICE menu select DIGITAL INPUTS.
- Set the input types of fire damper switches.
- In the SERVICE menu select SAVE CHANGES/SAVE SETTINGS and RESTART (AHU).

5.5.3. FIRE AND FIREPLACE PROTECTION INPUTS

FIRE PROTECTION INPUT configuration:

- In the SERVICE menu select MAIN.
- Set the FIRE PROTECTION 1 parameters.
- In the SERVICE menu select DIGITAL INPUTS.
- Set the FIRE PROTECTION INPUT type.
- In the SERVICE menu select SAVE CHANGES/SAVE SETTINGS and RESTART (AHU).

FIREPLACE PROTECTION INPUT configuration:

- In the SERVICE menu select FANS.
- ENABLE airflow protection as fireplace protection.
- In the SERVICE menu select DIGITAL INPUTS.
- Set the FIRE PLACE PROTECTION INPUT type.
- In the SERVICE menu select SAVE CHANGES/SAVE SETTINGS and RESTART (AHU).

5.5.4. EXTERNAL HEATER, COOLER (COIL2)

To configure Coil2 as a DX cooler:

- In the SERVICE menu select COOLERS.
- Set DX cooler type and other available parameters for DX cooler.
- In the SERVICE menu select DIGITAL INPUTS.
- Set DX cooler protection input type.
- In the SERVICE menu select SAVE CHANGES/SAVE SETTINGS and RESTART (AHU).

To configure Coil2 as a Combined heating/cooling coil:

- In the SERVICE menu select COOLERS.
- Set hydronic cooler type as COOLER/HEATER and changeover type.
- In the SERVICE menu select SENSORS.
- Set hydronic cooler return fluid temperature sensor type and other sensor parameters.
- In the SERVICE menu select SAVE CHANGES/SAVE SETTINGS and RESTART (AHU).

To configure Coil2 as a water heater:

- In the SERVICE menu select HEATERS.
- Set supply air heater type as HYDRONIC and other preferred parameters for water heater.
- In the SERVICE menu select SENSORS.
- Set hydronic heater return fluid temperature sensor type and other sensor parameters.
- In the SERVICE menu select SAVE CHANGES/SAVE SETTINGS and RESTART (AHU).

5.5.5. EXTERNAL PREHEATER (COIL3)

To configure Coil3 as an electrical preheater:

- In the SERVICE menu select HEATERS.
- Set outdoor air pre-heater type as ELECTRICAL 0..10 and other preferred parameters for electrical preheater.
- In the SERVICE menu select DIGITAL INPUTS.
- Set input types of pre-heater manual and automatic protection inputs.
- In the SERVICE menu select SAVE CHANGES/SAVE SETTINGS and RESTART (AHU).

To configure Coil3 as a water preheater:

- In the SERVICE menu select HEATERS.
- Set outdoor air pre-heater type as HYDRONIC.
- In the SERVICE menu select SENSORS.
- Set hydronic pre-heater return fluid temperature sensor type and other sensor parameters.
- In the SERVICE menu select SAVE CHANGES/SAVE SETTINGS and RESTART (AHU).

5.5.6. AIR QUALITY SENSORS WITH ANALOG OUTPUT

- In the **SERVICE** menu select **SENSORS**.
- Set the **AIR QUALITY SENSOR 1** type.
- Set other available parameters for **AIR QUALITY SENSOR 1**.
- Set the **AIR QUALITY SENSOR 2** type.
- Set other available parameters for **AIR QUALITY SENSOR 2**.
- In the **SERVICE** menu select **SAVE CHANGES/SAVE SETTINGS** and **RESTART (AHU)**.

5.5.7. CUSTOM SWITCHES

- In the **SERVICE** menu select **DIGITAL INPUTS**.
- Set the **SYSTEM MODE SWITCH** input type.
- Set the **FAN SPEED SWITCH** input type.
- In the **SERVICE** menu select **SAVE CHANGES/SAVE SETTINGS** and **RESTART (AHU)**.

To change default actions of custom switches activation:

- For the ST-SA-Control or SALDA AIR app in the **SERVICE** menu select **MAIN**. For the web interface in the **ADJUSTER** menu select **USER SETTINGS**.
- Set preferred **SYSTEM MODE SWITCH** parameters.
- Set preferred **FAN SPEED SWITCH** parameters.
- In the **SERVICE (ADJUSTER for web interface)** menu select **SAVE CHANGES/SAVE SETTINGS** and **RESTART (AHU)**.

5.6. OPERATING THE UNIT

The air handling unit can be controlled via ST-SA-Control remote control panel, web interface or SALDA AIR mobile application. The unit has different system modes with different fan speed presets:

- **STAND-BY** – the system is turned off.
- **BUILDING PROTECTION** – the main objective of this mode is to protect premises against moisture accumulation.
- **ECONOMY** – this mode is designed to save energy when people are absent on the premises.
- **COMFORT** – this mode is used when people are present on the premises.

System modes can be changed by the following functions (in sequential order):

- Weekly Schedule
- Switching on is activated from an external contactor
- Manual mode selection
- Holiday Schedule
- Stand-by mode blocking



More advanced details of unit operation can be found in the Air Handling unit's controller (MCB) manual, section **"FUNCTIONAL DESCRIPTION"**. Follow the link on the last page of this document.



If the unit is going to be started for the first time be aware to follow the instructions in the section **"OPERATIONS PRIOR TO THE FIRST START"**.

5.6.1. ST-SA-CONTROL REMOTE CONTROL PANEL AND SALDA AIR APP

ST-SA-Control is an easy-to-use remote controller. It connects to the air handling unit's controller via the RS485 interface.



Fig. 5.6.1.1 ST-SA-Control remote controller

After the Air Handling unit is connected to the mains and the safety switch is turned on, the remote controller should load up and connect to the unit's controller (connection can be automatic or manually chosen). Adjuster's user password by default – 1111.

SALDA AIR is a mobile application (may be downloaded from Google Play Store or Apple App Store) that allows users to control AmberAir Compact units using a Smartphone or tablet. The application can access the air handling unit's controller via a local network with a WIFI access point (the unit must be connected to the local network through MB-Gateway device).

SALDA AIR



Fig. 5.6.1.2 SALDA AIR application

After the Air Handling unit is connected to the mains, connected to the local network (via MB-Gateway) and the safety switch is turned on, the Smart device can connect to the same local network and use the SALDA AIR application to automatically or manually access the unit's controller. Adjuster's user password by default – 1111.

To change the fan speed (different mode) on the remote controller or mobile application, press **SYSTEM MODE** on the main screen and select the desired speed (mode). Shortly after the mode is set, the fan speed will change.

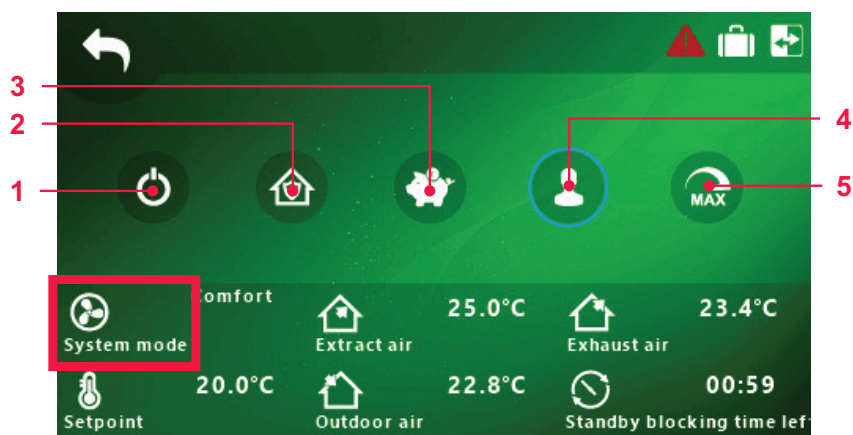

Fig. 5.6.1.3 ST-SA-Control and SALDA AIR system mode screen view

NO.	ICON	LABEL	DESCRIPTION
1		STANDBY	
2		BUILDING PROTECTION	Options: • BOOST TIMER
3		ECONOMY	Options: • BOOST TIMER
4		COMFORT	Options: • BOOST TIMER
5		BOOST TIMER	

To change temperature setpoint on the remote controller or mobile application, press **SETPOINT** on the main screen and select desired temperature.



Fig. 5.6.1.4 ST-SA-Control and SALDA AIR temperature setpoint screen view



More details on unit operation and ST-SA-Control remote controller are provided in the ST-SA-CONTROL manual. Follow the link on the last page of this document.

5.6.2. WEB INTERFACE

The AmberAir Compact units can also be controlled using a computer. When the air handling unit is connected to a local network (via an additional device – MB-Gateway), a computer of the same network can access the unit.



Fig. 5.6.2.1 MB-Gateway web interface

After the Air Handling unit is connected to the mains, connected to the local network (via MB-Gateway) and the safety switch is turned on, the computer can connect to the same local network and access the unit's controller. To connect to the unit: in the address window of the Internet browser enter MB-Gateway's hostname, login to it (by default: user name – *admin*; password: *admin*) and select **VENTILATION CONTROL**.

To change the system mode (different fans speed) and temperature setpoint, choose the mode selector (lower left corner on the main window) and set the desired mode and temperature.

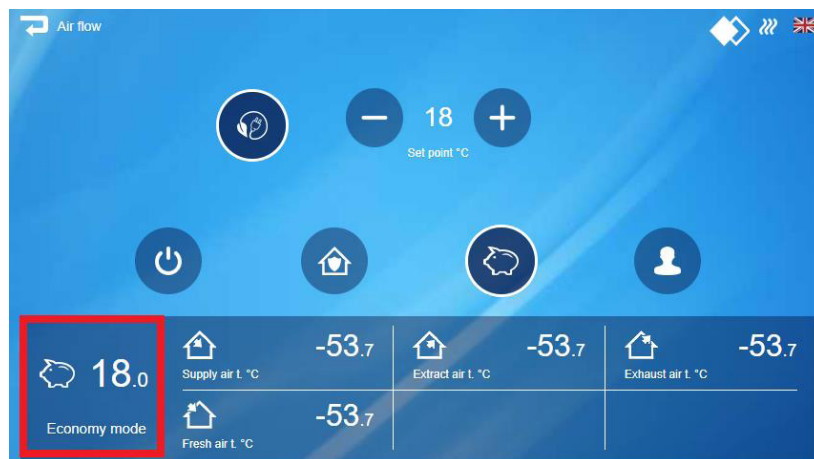

Fig. 5.6.2.2 MB-Gateway mode selector screen view

6. MAINTENANCE



Unplug the unit from the mains before opening the door (disconnect the power plug from the outlet, or in case an automatic circuit breaker is installed, disconnect it as well. Make sure that it cannot be turned on by the third parties) and wait until the fans completely stop (for about 2 min.).



The condensate tube must be filled with water as indicated during the first start-up before every heating season!

6.1. MAINTENANCE INTERVALS

In order to ensure the proper functioning of the system, maintenance requirements and its periods should be observed. Otherwise, the warranty shall be void. Some recommendations are provided in the table below, but they are just advisory, as the need for system maintenance depends on the location of the unit installation, the pollution of the atmosphere, population, working hours, etc.

Item to check	Action	Intervals (months)	
		6	12
Filters	Replace when the display screen indicates a filter alarm.	X	
	Check that the filter installation frame is in working condition and secured.	X	
	Check the setting and function of the differential pressure gauge (switches, digital, sloping tube).	X	
Fans	Check the cleanness and condition of the impeller and the chamber inside.	X	
	Check the impeller for free rotation.	X	
	Check the tightness of the cables in the electric motor terminal board.	X	
Heat exchanger	Check the integrity of the exchanger heat-transfer surface.	X	
	Check the cleanness of the exchanger heat-transfer surface.	X	
	Check the rotor belt tension.	X	
Water heater/cooler	Check the integrity of the exchanger heat-transfer surface.	X	
	Check the cleanness of the exchanger heat-transfer surface.	X	
	Check the tightness of the exchanger on the side of the working fluid.	X	
	Check the condition of the connection of the exchanger hydraulic circuit.	X	
Electrical heater	Check the heating rods for damage.	X	
	Check the heating rods for cleanness.	X	
	Check the cleanness of other heater elements.	X	
	Check the condition of the wiring (condition of the cables, wires, tightening of the cables and wires, etc.).	X	
Duct accessories	Inspect and clean if necessary.	X	
Internal surface	Inspect and clean if necessary.	X	
External surface	Inspect and clean if necessary.		X
Gaskets, sealing strips, bearings, drive belts	Inspect and clean if necessary.		X
Sensors, cabling, measuring tubes	Inspect and clean if necessary.		X
Functionality inspection			
Switching unit (contactor)	Every 6 months: visually assess the functioning of the switching unit (contactor), i.e., make sure that its casing has no signs of melting or is not thermally damaged and does not produce any unusual sounds. All the contactors in the product or in its accessories must be checked.	X	
Safety functions, fire and frost protection, etc.	Inspect the functionality.		X
Other control functions	Inspect the functionality. Compare the air handling unit's values with the commissioning report. Remedial measures should be taken to correct any possible inconsistencies.		X
Alarm history	Review		X

6.2. OPENING THE DOOR



It's necessary to stop the unit before opening it's doors. Disconnect the main switch and open doors after fans stop completely (approximately 2 min.). It necessary to assure, that the main switch cannot be turned on by the third parties.

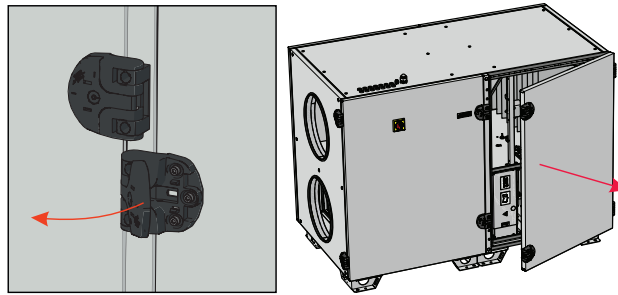

Fig. 6.2.1 AmberAir Compact S-R-1000-5000-H

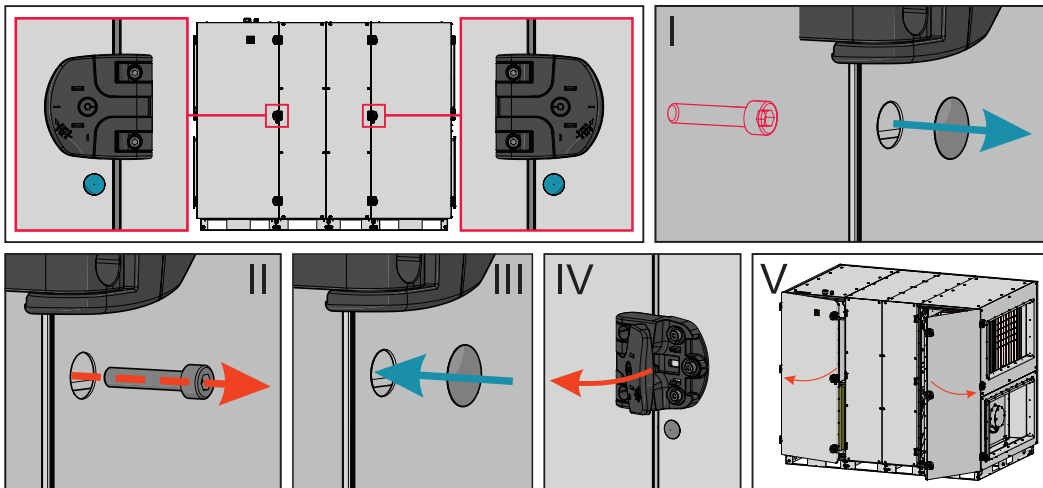

Fig. 6.2.2 AmberAir Compact S-R-7000-9000-H



ATTENTION! Remove safety screw before opening!

6.3. FRONT DOOR REMOVAL

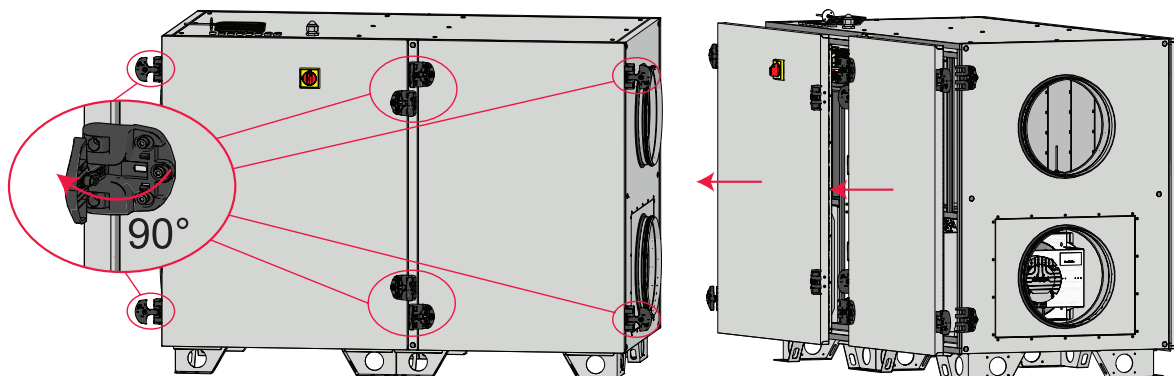

Fig. 6.3.1 AmberAir Compact S-R H

6.4. BACK COVER REMOVAL

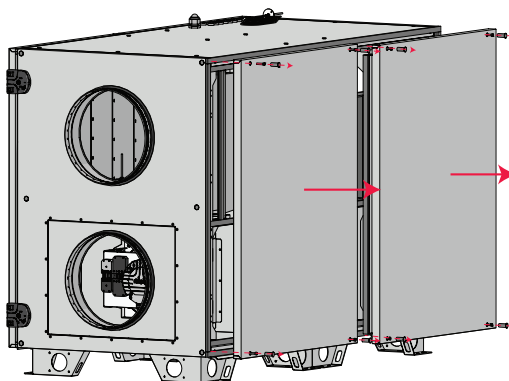

Fig. 6.4.1 AmberAir Compact S-R H

6.5. FILTER REPLACEMENT

Filters must be replaced when their clogging is indicated on any of the unit's control environment's. Filter clogging is detected by the pressure device. It is recommended to change it according to the signal on the control device, at least twice a year: before and after the heating season. Filters are made for single use – it is not recommended to vacuum, shake or otherwise clean them. When changing filters, it is important to stop the unit, as dust from the filters may enter it. The filter section should also be cleaned when changing filters.

¹ Contaminated filters unbalance the ventilation system and the unit starts using more energy.

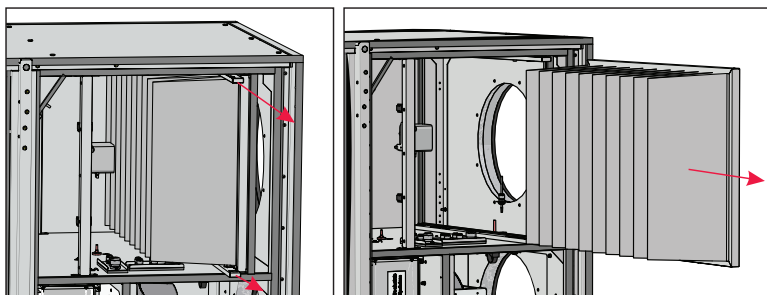

Fig. 6.5.1 AmberAir Compact S-R H

In order to remove the filters, open the door of the unit and take off the filters. Dirt increases air resistance in the filter, therefore, a lower amount of air is supplied into the premises. Arrows on the filters must comply with the airflow direction.



The instruction on reloading is provided in the particular unit's control environment's documentation. Operation of the unit without filters is not allowed.

6.6. HEAT EXCHANGER MAINTENANCE

⚠ Prior to commencing any maintenance or repair works, make sure the unit is disconnected from the power source.

⚠ CAUTION: the heat exchanger cannot be used when the filters are removed!

- Maintenance works may only be started after a full stop of the fans.
- Clean the heat exchanger once a year.
- Wash in hot soapy water or use pressure air. Do not use detergent containing ammonia.
- Check that the brushes are undamaged.
- Check 2 times per year if driving belt is sufficiently taut, that it follows and that it is undamaged. If belt tension is too low it needs to be shortened or replaced.
- Be sure that the fan is disconnected from power source before performing any maintenance or repair works.
- When performing technical maintenance works, follow all work safety rules.
- Before starting the unit, make sure that no tools or other foreign items have been left.

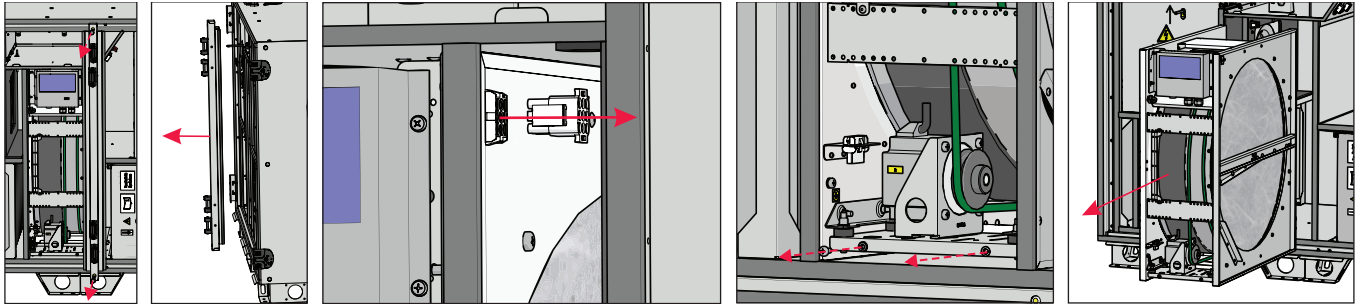

Fig. 6.6.1 AmberAir Compact S-R-1000-5000-H

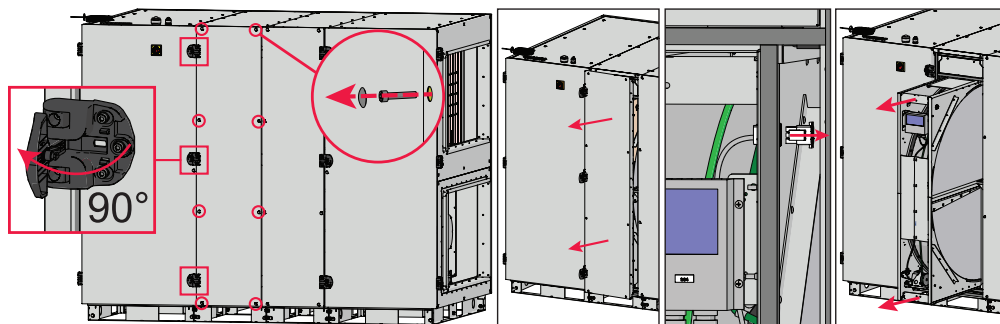

Fig. 6.6.2 AmberAir Compact S-R-7000-9000-H

6.7. FANS MAINTENANCE

Fans get dirty, which reduces their efficiency.

⚠ Prior to commencing any maintenance or repair works, make sure the unit is disconnected from the power source.

⚠ Do not use water.

- Observe staff safety regulations during the maintenance and repair works.
- Make sure the fan ball bearings do not make excessive noise.
- The motor features a heavy-duty ball-bearing design. The motor is completely sealed and grease-free.
- Detach the fan from the unit.
- Make sure the impeller is in balance.
- The impeller should be particularly checked for built-up material or debris that may cause an imbalance. An excessive imbalance may lead to accelerated wear on the motor bearings and cause vibration.
- Clean the impeller and inside the housing with a mild detergent and a damp soft cloth.
- If necessary, clean fan housing section of the unit.
- Do not use high-pressure cleaners, abrasive materials and sharp tools or caustic solvents that may scratch or damage the housing and impeller.
- Do not plunge the motor in any fluid while cleaning the impeller. Make sure the impeller's balance weights are in place.
- Make sure the impeller is free of any obstacles.
- Install the fan back into the unit. Connect fan power and control signals.
- In case the fan does not automatically start up or stop after maintenance, contact the manufacturer. The malfunction of the fan can be identified by the pressure in the system (when pressure switches are connected). In case of any fault in the fan motor, a notice will appear on the control panel.

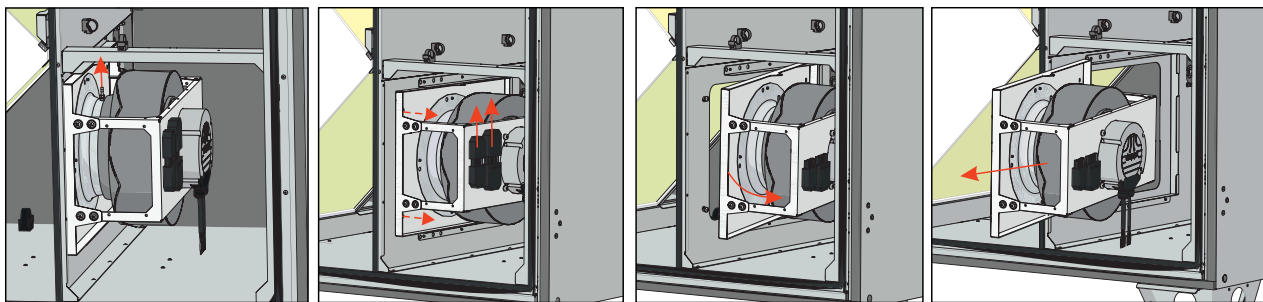

Fig. 6.7.1 AmberAir Compact S-R-1000-5000-H

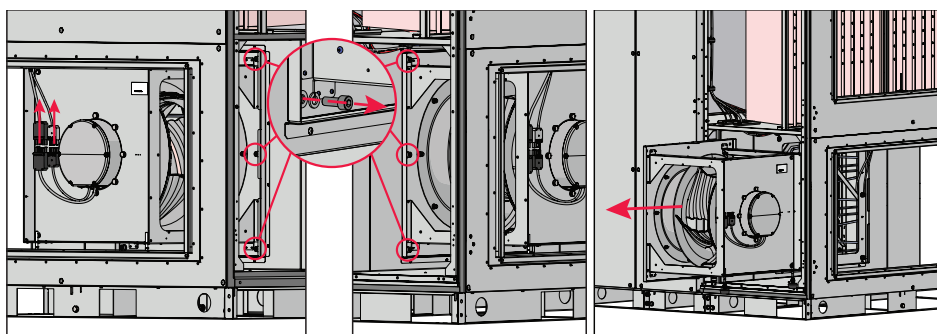

Fig. 6.7.2 AmberAir Compact S-R-7000-9000-H

6.8. ELECTRICAL HEATER MAINTENANCE

- For electric air heaters, check that they are securely fastened, that the wiring connections are not loose and that the heating elements are not folded. They may be bent due to uneven heating when uneven air flow passes through them. Check the heater for unnecessary items and contamination of the heating elements, as this can cause unwanted odours and, in the worst case, dust can ignite. The heating elements can be cleaned with a vacuum cleaner or a damp cloth.
- In case manual protection is activated, check for a fault before pressing the RESET button. If the fault is identified after it has been rectified, press the RESET button using a screwdriver or a similar object.
- Electrical heater does not require additional servicing. The filters must be replaced as described above.
- Heaters are equipped with 2 thermal protection devices: an automatic self-resetting protection device that is activated at +50 °C, and a manually restored protection device that is activated at +100 °C.
- After activation of the manually restored protection device, make sure that the unit is disconnected from the power supply. Wait until all heating elements cool down and the fans stop completely. After the failure is detected and rectified, press the RESET button before starting the unit. The failure can be identified by a qualified technician only.
- If necessary, the electric heater can be removed. Disconnect the electrical connector from the heater and remove the heater.

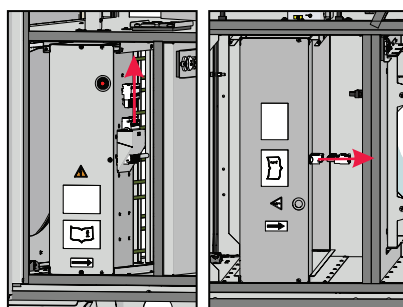

Fig. 6.8.1 Disconnecting an electrical connector

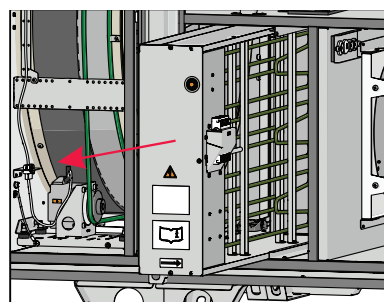

Fig. 6.8.2 Removing the heater

6.9. WATER COIL MAINTENANCE

It is recommended to check the condition of the coil periodically and clean it. Check that the coil plates are not folded and that the seal is tight. Clean with a vacuum cleaner on the air inlet side or compressed air on the air outlet side. If heavily soiled, cleaning can be done by spraying warm water with a detergent that does not corrode aluminium. Check that the coil is well drained and that the return water temperature sensor is well secured.

6.10. CHECKING THE DAMPERS

The incomplete opening of the outdoor air damper creates additional resistance in the system causing excessive energy consumption. If a valve that does not close completely the water air coil may freeze when the unit is turned off, and cold air will enter the premises undesirably. The mounting and operation of the valve actuator should be checked and adjusted.

6.11. CONTROL BOARD MAINTENANCE

- Open the unit's door.
- Remove the control box cover.
- Disconnect all necessary cables, wires, hoses and connectors in order to remove the control board and unscrew the control board mounting bolts.
- Remove the control board.
- To reassemble, follow all maintenance steps in reverse order. When re-connecting cables, wires, hoses and connectors, make sure to match each wire, hose and connector to the corresponding connection terminal and connector.

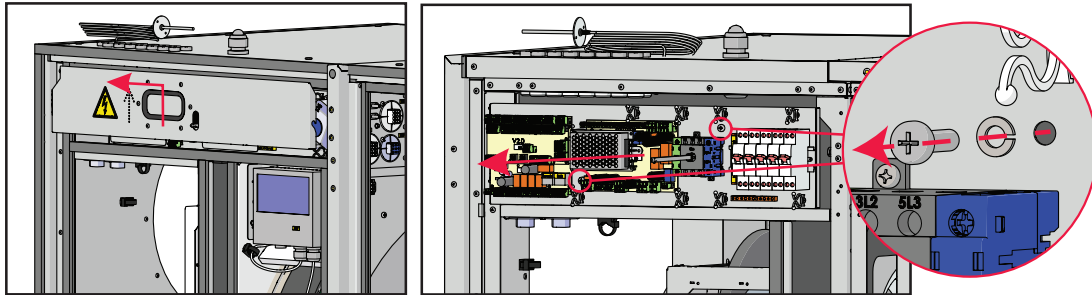

Fig. 6.11.1 AmberAir Compact S-R H

7. TROUBLESHOOTING

7.1. SYSTEM NOTIFICATIONS

The system notifies the user about the failures by warnings that are cancelled automatically and by alarms that have to be cancelled manually. It is recommended that the alarms are cancelled by a specialist prior to detection of the causes of the alarm. Information about alarms/warnings is displayed on a particular unit's control environment's main window. The alarms can be cancelled in the same control environment. If at least one alarm is active, the system is shut down and an external failure indication is activated.



More information about controller notifications can be found in the Air Handling unit's controller (MCB) manual, section "DIS-PLAY AND CANCELLATION OF ALARMS AND WARNINGS". Follow the link on the last page of this document.

7.2. POSSIBLE FAULTS AND TROUBLESHOOTING

FAILURE	CAUSE	EXPLANATION / CORRECTIVE ACTIONS
The unit is not operating	No supply voltage	Check whether the device is connected to the power network.
	The protection device is off or a current leakage relay is active (if installed by the installer)	Switch on only if the unit condition has been evaluated by a qualified electrician. If the system failed, the failure MUST BE rectified prior to switching the system on.
The air supply heater or pre-heater is not operating or malfunctioning (if installed)	Too low airflow in air ducts activates automatic protection	Check if the air filters are not clogged Check if the fans are rotating.
	Manual protection is activated	Possible heater or unit failure. MUST contact the servicing staff for failure detection and its elimination.
The filters are clogged and no message is shown on the remote control	Wrong time in filter timers or their switch is broken, or its pressure is set improperly	Shorten filter timer time till the message of clogged filters appears or replace the pressure switch of the filters, or set their proper pressure.
Fan(s) do not start	The control system stopped the fans	Check if there are any alarm messages. Check the settings in the control panel (time, week scheduler, operating, control modes, etc.)
	The fan protection device is off	Switch on only after the unit condition has been evaluated by a qualified electrician. If the system failed, the failure MUST BE rectified prior to switching the system on.
Reduced airflow	Control configuration set-up	Check the settings for operating mode setpoints.
	The airflow system is clogged or damaged	Check if the filters need changing. Check if the diffusers and/or louvres need cleaning. Check if the fans and/or exchanger block need cleaning. Check if the air intake is clogged. Check the ducts for visible damage and/or build-up with dust/dirt.
	Openings of the airflow system not operating correctly	Check that the outdoor/exhaust air damper (if used) opens. Check the diffuser/louvre openings.
Cold supply air	Control configuration set-up	Check the temperature settings in the control panel.
	The extract air filter is clogged	Check if the extract air filter has to be changed.
	Manual electrical heater protection is activated	Possible heater or unit failure. MUST contact the servicing staff for failure detection and its elimination.
Noise/vibrations	Incorrect unit placement	Check that the unit is completely leveled.
	Dirty fan impellers	Clean the fan impellers.
	The fan is not securely attached to the unit	Check that the screws holding the fans are tightened properly.
Rotor belt alarm appeared	Broken rotor heat exchanger belt	Install spare belt

8. TECHNICAL DATA

8.1. DIMENSIONS

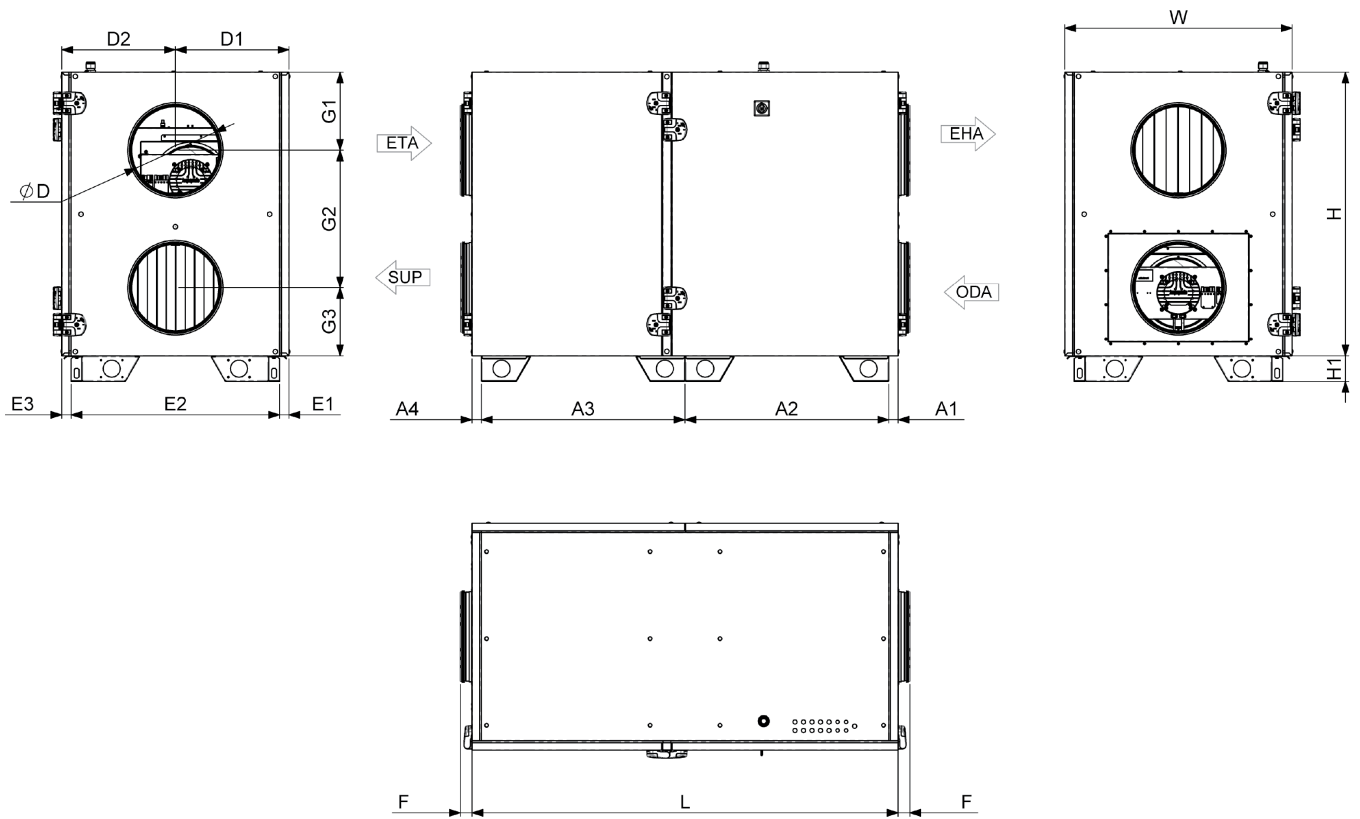

Fig. 8.1.1 AmberAir Compact S-R-1000-H-E-L-C1 / AmberAir Compact S-R-1500-H-E-L-C1 dimensions

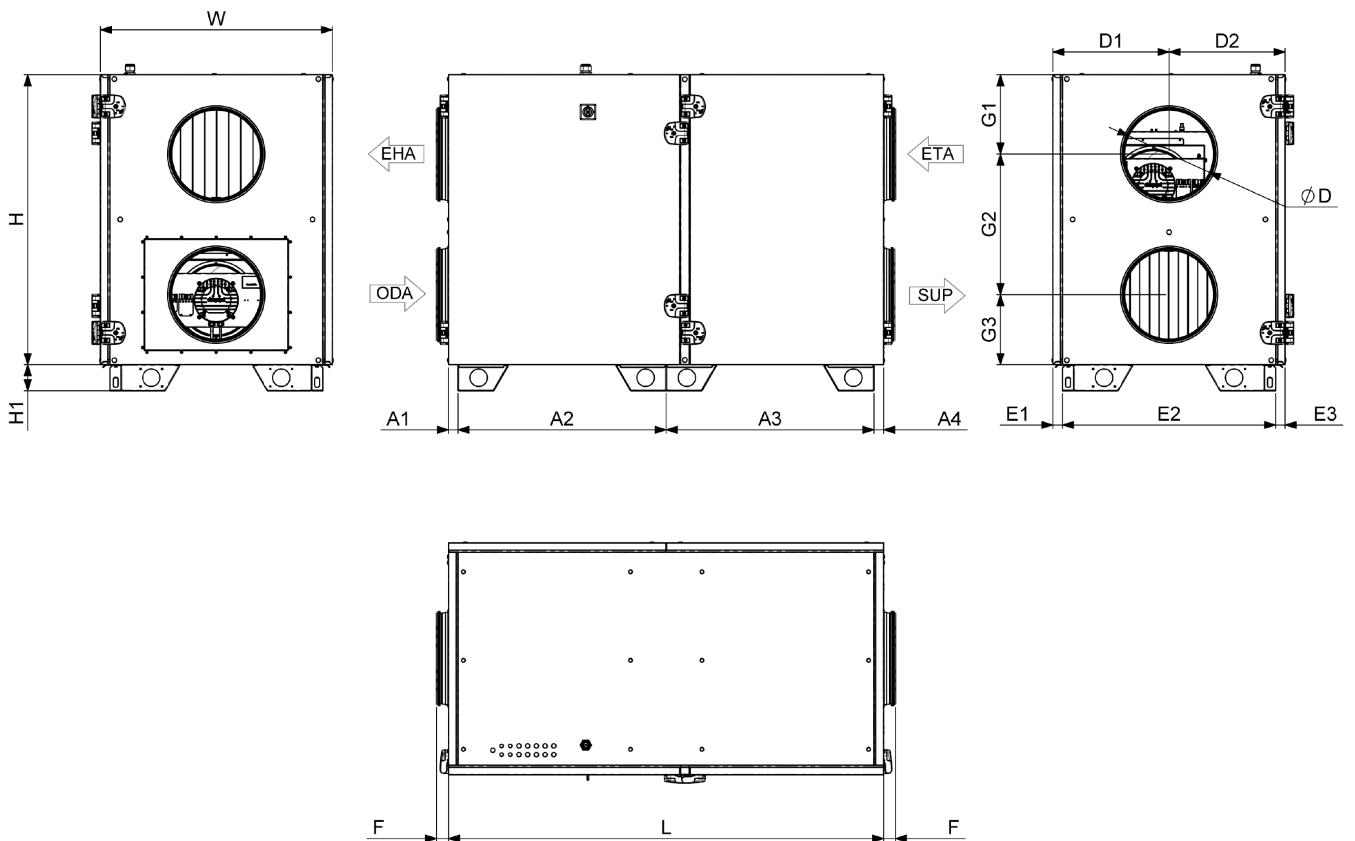
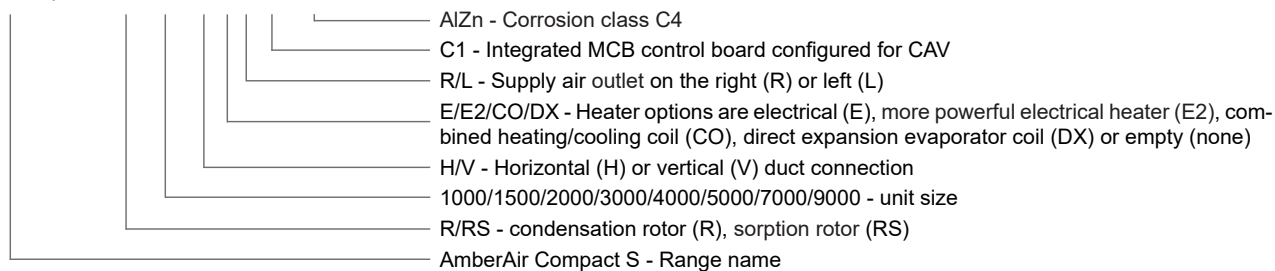

Fig. 8.1.2 AmberAir Compact S-R-1000-H-E-R-C1 / AmberAir Compact S-R-1500-H-E-R-C1 dimensions

AMBERAIR COMPACT S-R/RS		1000-H-L-C1	1000-H-E-L-C1	1000-H-R-C1	1000-H-E-R-C1	1500-H-L-C1	1500-H-E-L-C1	1500-H-R-C1	1500-H-E-R-C1
L	[mm]	1 500				1 550			
W	[mm]	800				850			
H	[mm]	1 000				1 050			
ØD	[mm]	315				355			
F	[mm]					41			
H1	[mm]					90			
A1	[mm]					33			
A2	[mm]	717				742			
A3	[mm]	717				742			
A4	[mm]					33			
D1	[mm]	400				425			
D2	[mm]	400				425			
E1	[mm]					33			
E2	[mm]	734				784			
E3	[mm]					33			
G1	[mm]	275				312			
G2	[mm]	484				489			
G3	[mm]	241				248			
WEIGHT	[kg]	194	198	194	198	219	225	219	225
INSULATION THICKNESS	[mm]	50							

AmberAir Compact S-R-1500-H-E-R-C1 AlZn



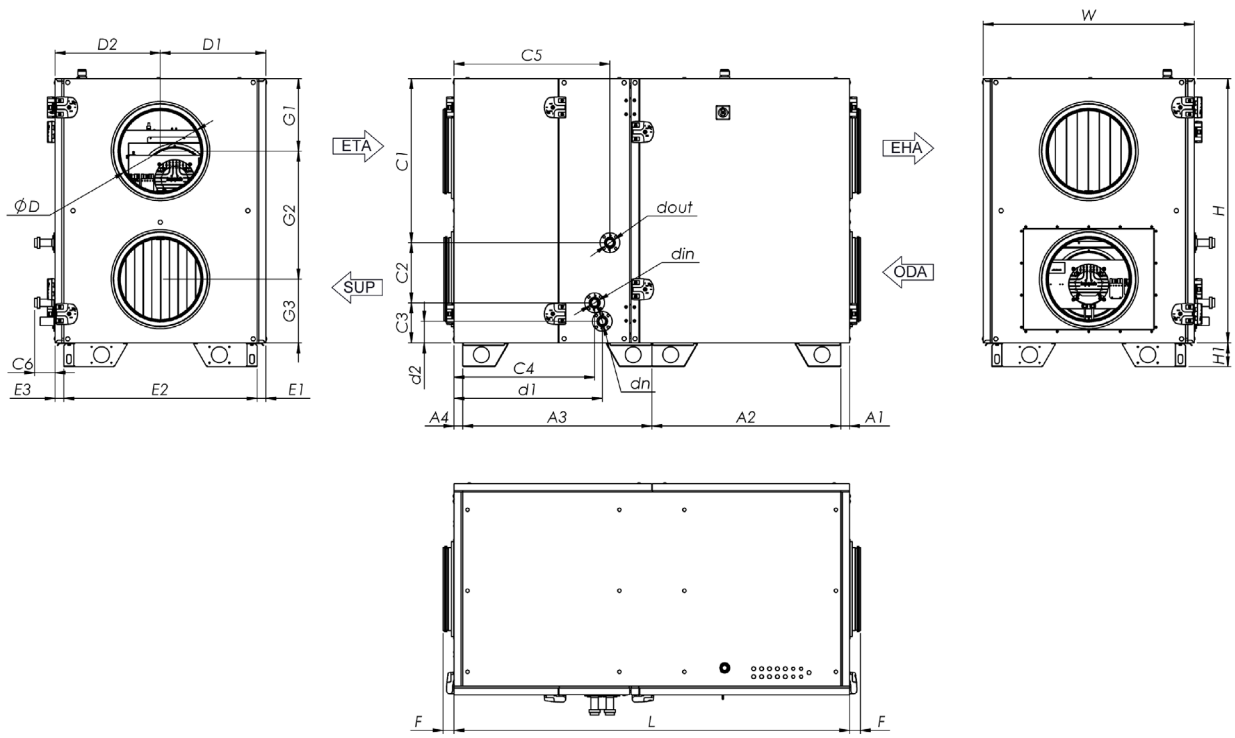

Fig. 8.1.3 AmberAir Compact-S-R-1000-H-CO-L-C1 / AmberAir Compact-S-R-1500-H-CO-L-C1 dimensions

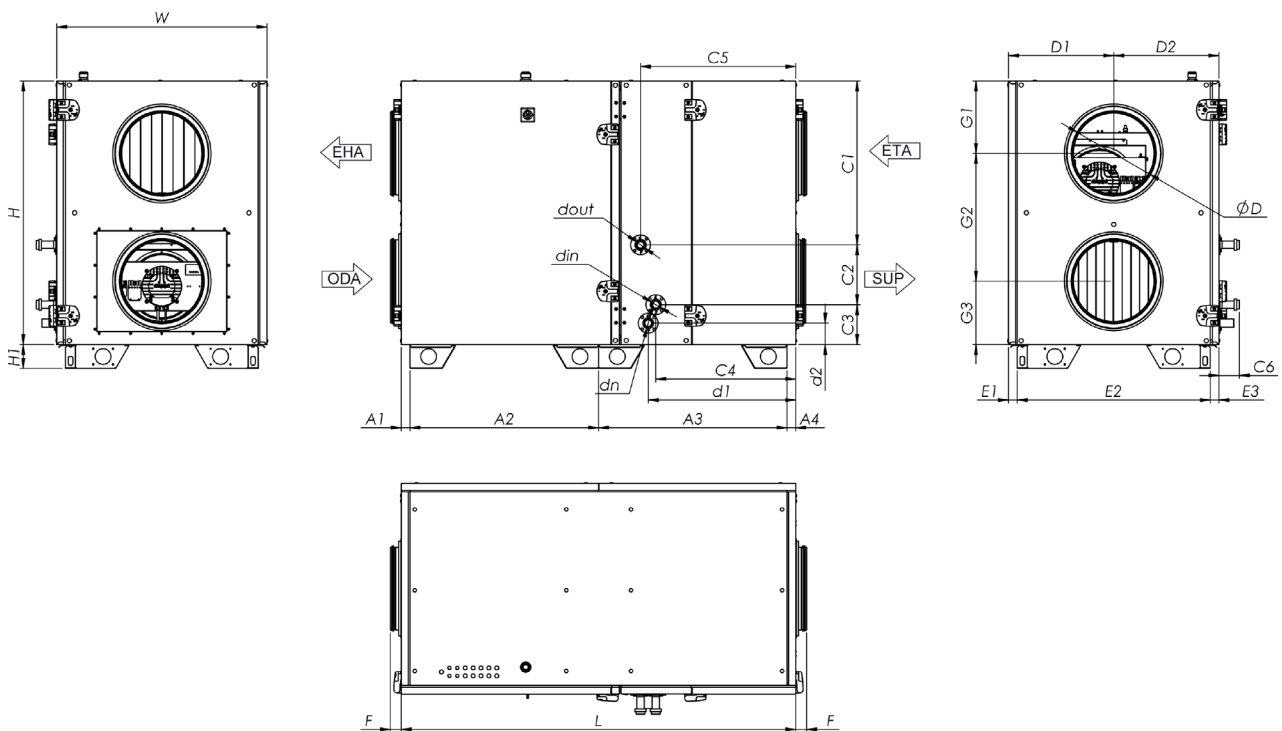
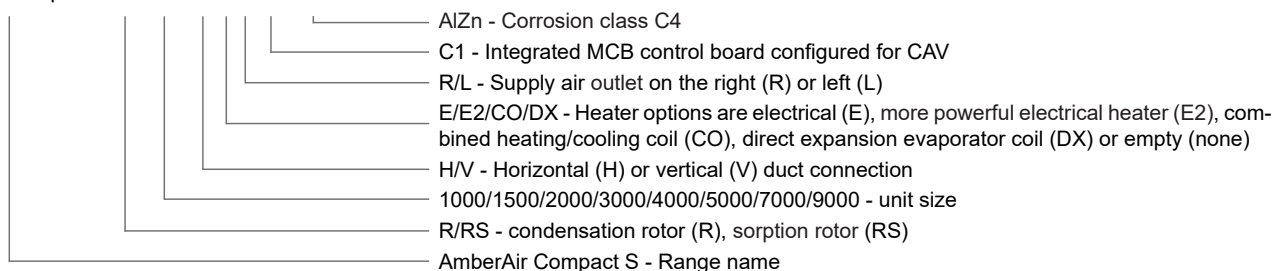

Fig. 8.1.4 AmberAir Compact-S-R-1000-H-CO-R-C1 / AmberAir Compact-S-R-1500-H-CO-R-C1 dimensions

AMBERAIR COMPACT S-R/RS		1000- H-CO-L-C1	1000- H-CO-R-C1	1500- H-CO-L-C1	1500- H-CO-R-C1
L	[mm]	1 500		1 550	
W	[mm]	800		850	
H	[mm]	1 000		1 050	
ØD	[mm]	315		355	
dn		32			
F	[mm]	41			
H1	[mm]	90			
A1	[mm]	33			
A2	[mm]	717		742	
A3	[mm]	717		742	
A4	[mm]	33			
C1	[mm]	621		640	
C2	[mm]	227		261	
C3	[mm]	152		149	
C4	[mm]	533		580	
C5	[mm]	591		638	
C6	[mm]	78			
D1	[mm]	400		425	
D2	[mm]	400		425	
din		1"			
dout		1"			
E1	[mm]	33			
E2	[mm]	734		784	
E3	[mm]	33			
G1	[mm]	275		312	
G2	[mm]	484		489	
G3	[mm]	241		248	
d1	[mm]	562		609	
d2	[mm]	81		78	
WEIGHT	[kg]	205		231	
INSULATION THICKNESS	[mm]	50			

AmberAir Compact S-R-1500-H-E-R-C1 AlZn



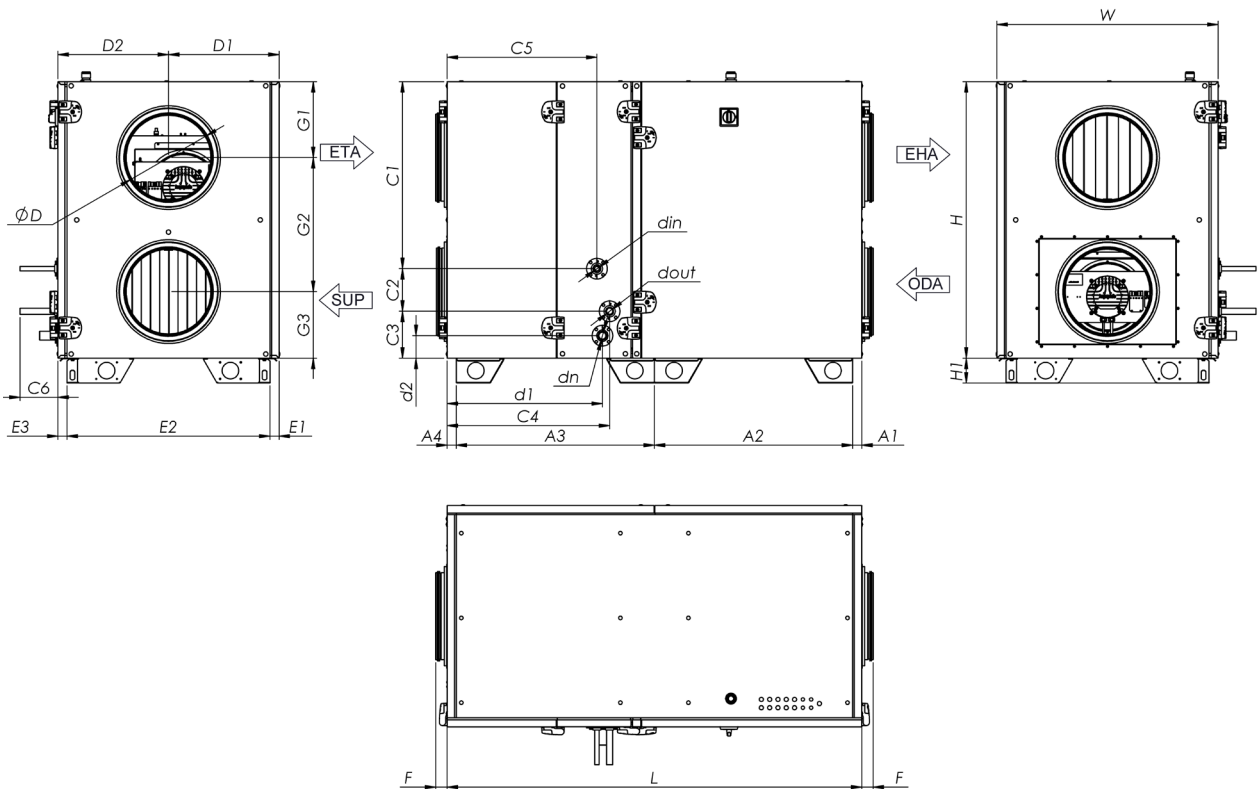

Fig. 8.1.5 AmberAir Compact-S-R-1000-H-DX-L-C1 / AmberAir Compact-S-R-1500-H-DX-L-C1 dimensions

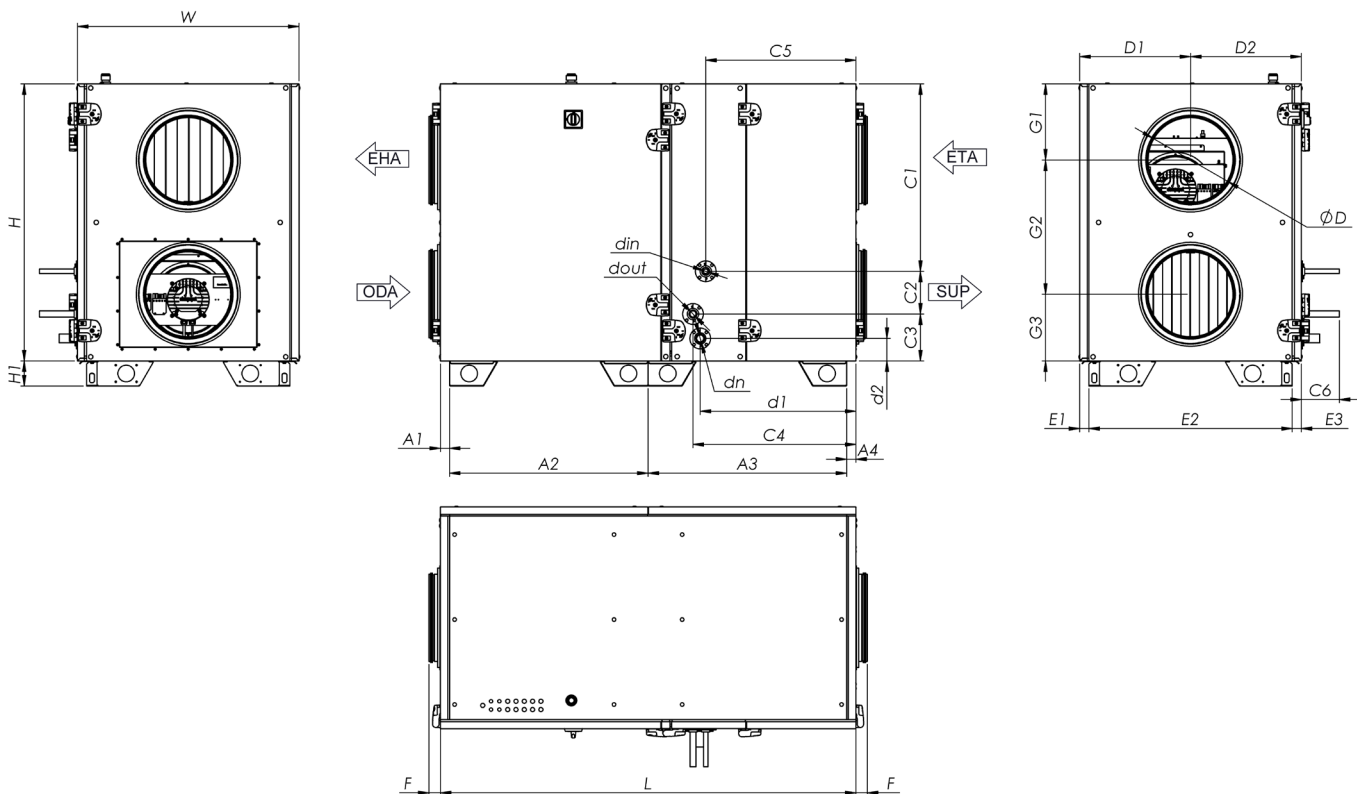
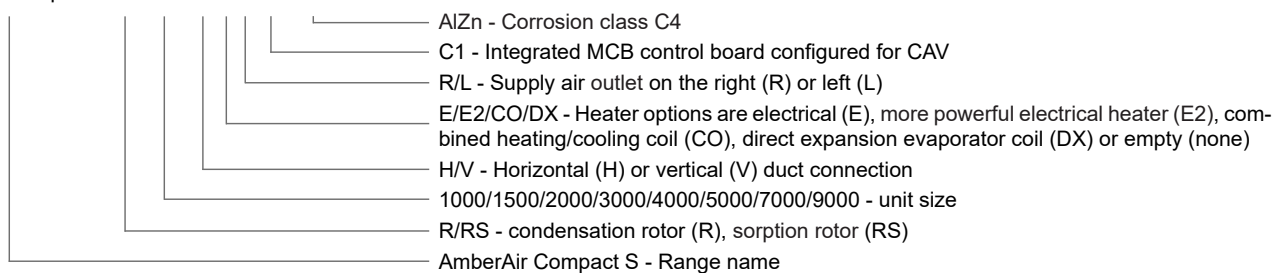

Fig. 8.1.6 AmberAir Compact-S-R-1000-H-DX-R-C1 / AmberAir Compact-S-R-1500-H-DX-R-C1 dimensions

AMBERAIR COMPACT S-R/RS		1000- H-DX-L-C1	1000- H-DX-R-C1	1500- H-DX-L-C1	1500- H-DX-R-C1
L	[mm]	1 500		1 550	
W	[mm]	800		850	
H	[mm]	1 000		1 050	
ØD	[mm]	315		355	
dn		32			
F	[mm]	41			
H1	[mm]	90			
A1	[mm]	33			
A2	[mm]	717		742	
A3	[mm]	717		742	
A4	[mm]	33			
C1	[mm]	676		717	
C2	[mm]	154		178	
C3	[mm]	170		155	
C4	[mm]	588		588	
C5	[mm]	542		642	
C6	[mm]	137		128	
D1	[mm]	400		425	
D2	[mm]	400		425	
din	[mm]	12		16	
dout	[mm]	12		22	
E1	[mm]	33			
E2	[mm]	734		784	
E3	[mm]	33			
G1	[mm]	275		312	
G2	[mm]	484		489	
G3	[mm]	241		248	
d1	[mm]	562		609	
d2	[mm]	81		78	
WEIGHT	[kg]	204		233	
INSULATION THICKNESS	[mm]	50			

AmberAir Compact S-R-1500-H-E-R-C1 AlZn



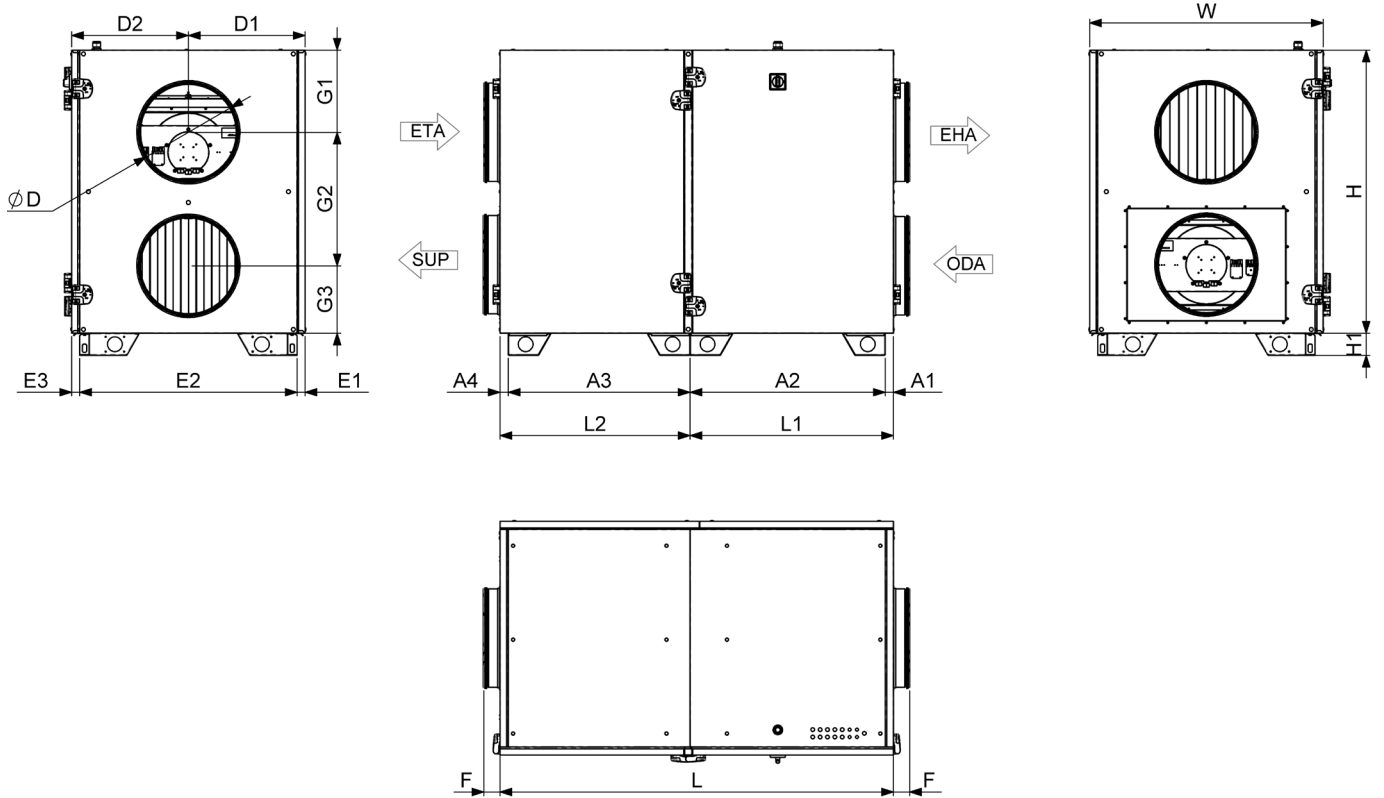

Fig. 8.1.7 AmberAir Compact-S-R-2000-H-E-L-C1 dimensions

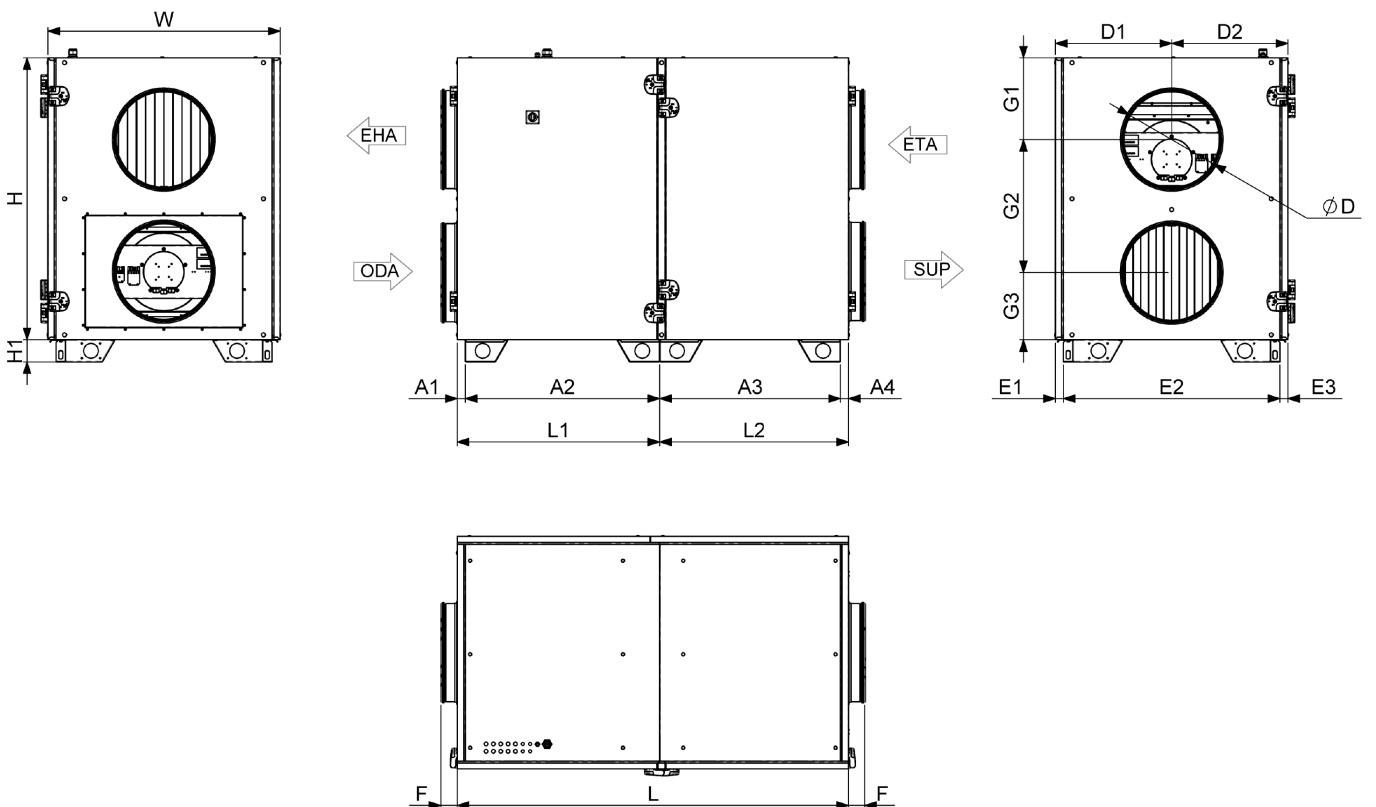
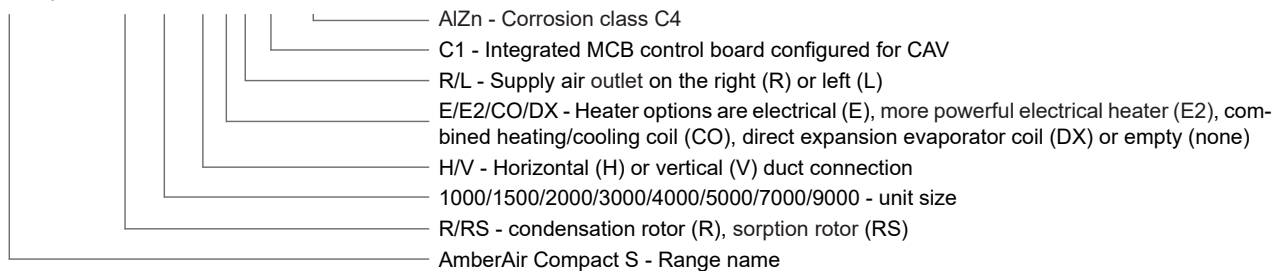

Fig. 8.1.8 AmberAir Compact-S-R-2000-H-E-R-C1 dimensions

AMBERAIR COMPACT S-R/RS		2000-H-L-C1	2000-H-E-L-C1	2000-H-R-C1	2000-H-E-R-C1
L	[mm]	1 600			
W	[mm]	950			
H	[mm]	1 150			
ØD	[mm]	400			
L1	[mm]	827			
L2	[mm]	773			
F	[mm]	66			
H1	[mm]	90			
A1	[mm]	33			
A2	[mm]	794			
A3	[mm]	740			
A4	[mm]	33			
D1	[mm]	475			
D2	[mm]	475			
E1	[mm]	33			
E2	[mm]	884			
E3	[mm]	33			
G1	[mm]	334			
G2	[mm]	543			
G3	[mm]	274			
WEIGHT	[kg]	266	272	266	272
INSULATION THICKNESS	[mm]	50			

AmberAir Compact S-R-1500-H-E-R-C1 AlZn



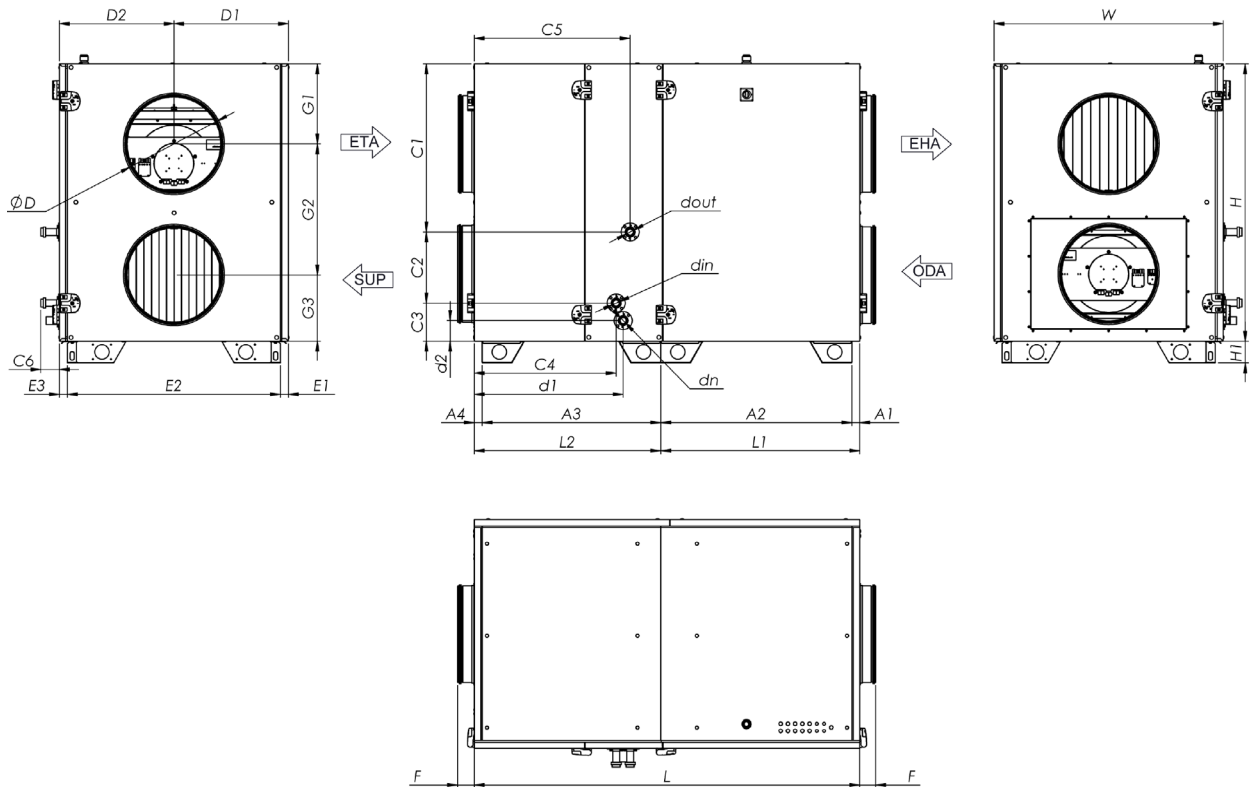

Fig. 8.1.9 AmberAir Compact-S-R-2000-H-CO-L-C1 dimensions

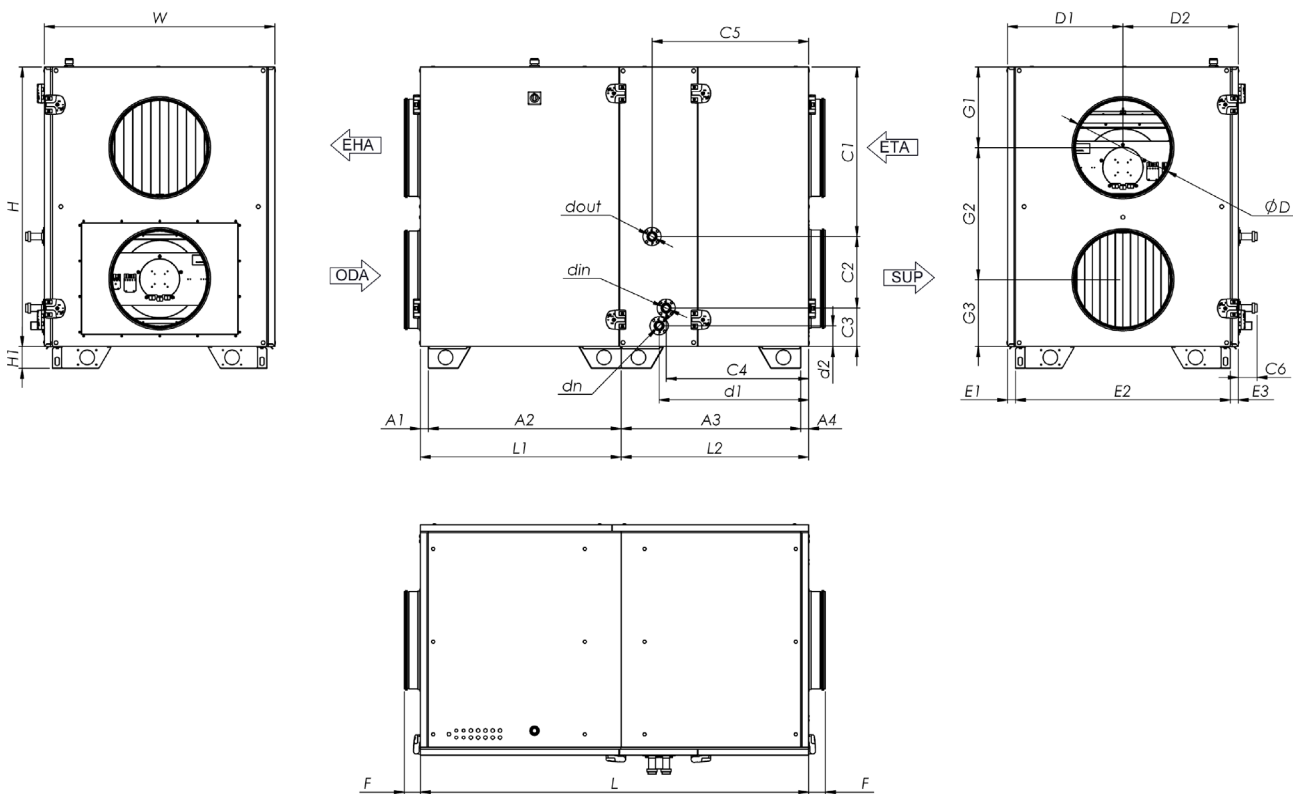
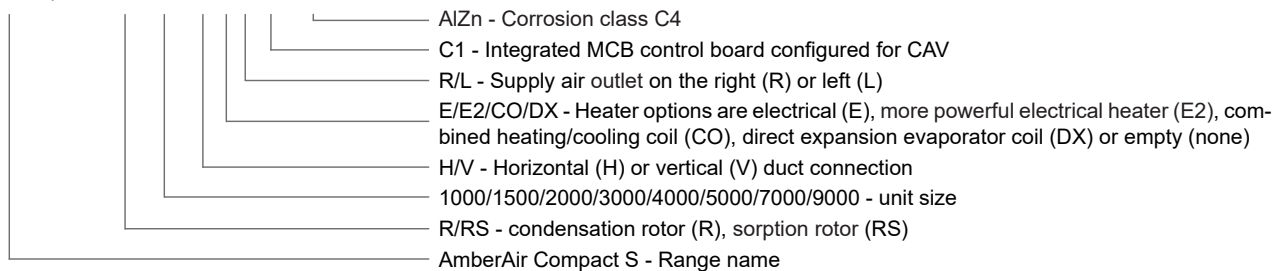

Fig. 8.1.10 AmberAir Compact-S-R-2000-H-CO-R-C1 dimensions

AMBERAIR COMPACT S-R/RS		2000-H-CO-L-C1	2000-H-CO-R-C1
L	[mm]		1 600
W	[mm]		950
H	[mm]		1 150
ØD	[mm]		400
L1	[mm]		827
L2	[mm]		773
dn			32
F	[mm]		66
H1	[mm]		90
A1	[mm]		33
A2	[mm]		794
A3	[mm]		740
A4	[mm]		33
C1	[mm]		698
C2	[mm]		294
C3	[mm]		158
C4	[mm]		589
C5	[mm]		647
C6	[mm]		78
D1	[mm]		475
D2	[mm]		475
din			1"
dout			1"
E1	[mm]		33
E2	[mm]		884
E3	[mm]		33
G1	[mm]		334
G2	[mm]		543
G3	[mm]		274
d1	[mm]		618
d2	[mm]		85
WEIGHT	[kg]		280
INSULATION THICKNESS	[mm]		50

AmberAir Compact S-R-1500-H-E-R-C1 AlZn



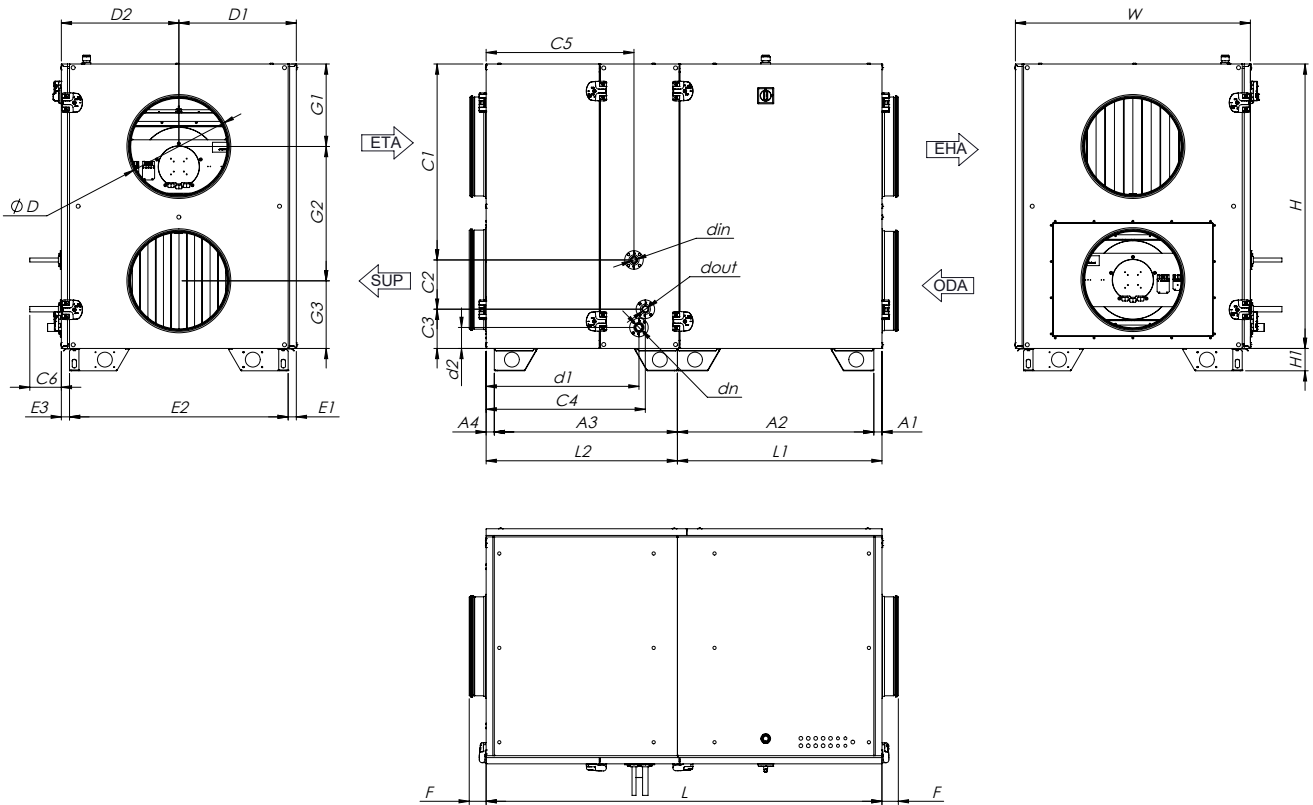

Fig. 8.1.11 AmberAir Compact-S-R-2000-H-DX-L-C1 dimensions

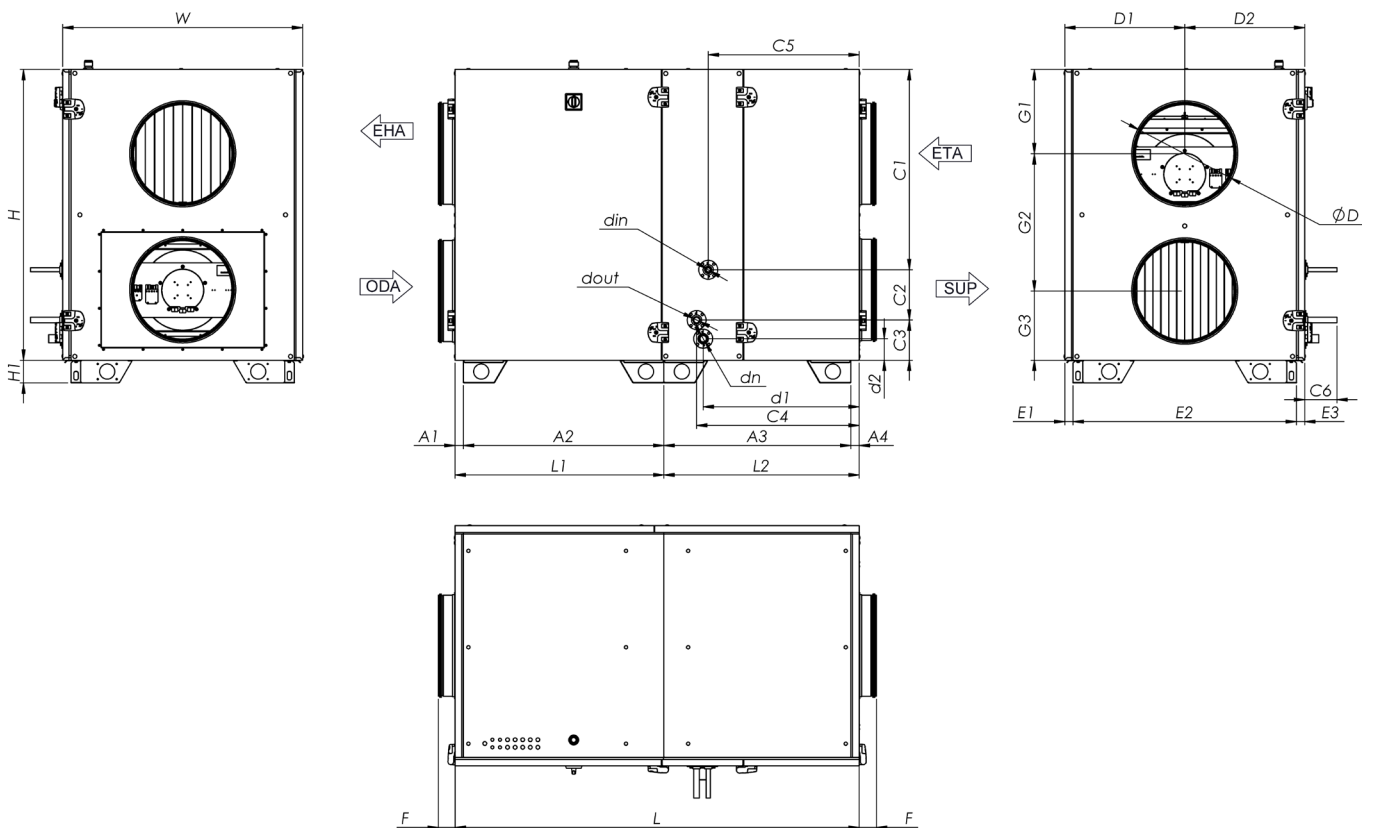
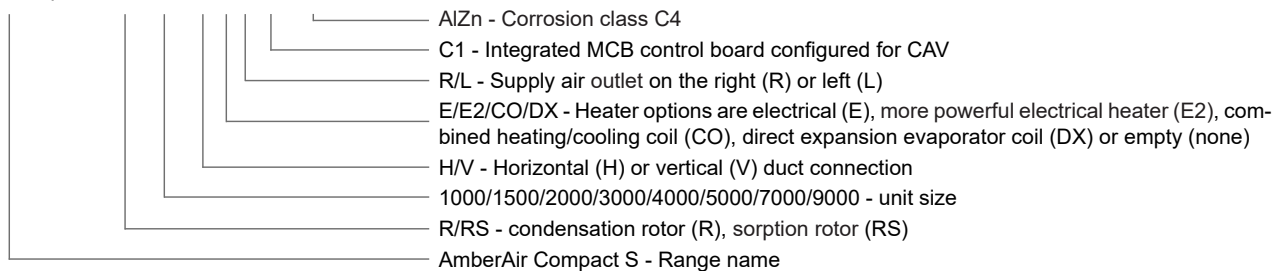

Fig. 8.1.12 AmberAir Compact-S-R-2000-H-DX-R-C1 dimensions

AMBERAIR COMPACT S-R/RS		2000-H-DX-L-C1	2000-H-DX-R-C1
L	[mm]	1 600	
W	[mm]	950	
H	[mm]	1 150	
ØD	[mm]	400	
L1	[mm]	827	
L2	[mm]	773	
dn		32	
F	[mm]	66	
H1	[mm]	90	
A1	[mm]	33	
A2	[mm]	794	
A3	[mm]	740	
A4	[mm]	33	
C1	[mm]	792	
C2	[mm]	199	
C3	[mm]	159	
C4	[mm]	644	
C5	[mm]	598	
C6	[mm]	127	
D1	[mm]	475	
D2	[mm]	475	
din	[mm]	16	
dout	[mm]	22	
E1	[mm]	33	
E2	[mm]	884	
E3	[mm]	33	
G1	[mm]	334	
G2	[mm]	543	
G3	[mm]	274	
d1	[mm]	618	
d2	[mm]	85	
WEIGHT	[kg]	282	
INSULATION THICKNESS	[mm]	50	

AmberAir Compact S-R-1500-H-E-R-C1 AlZn



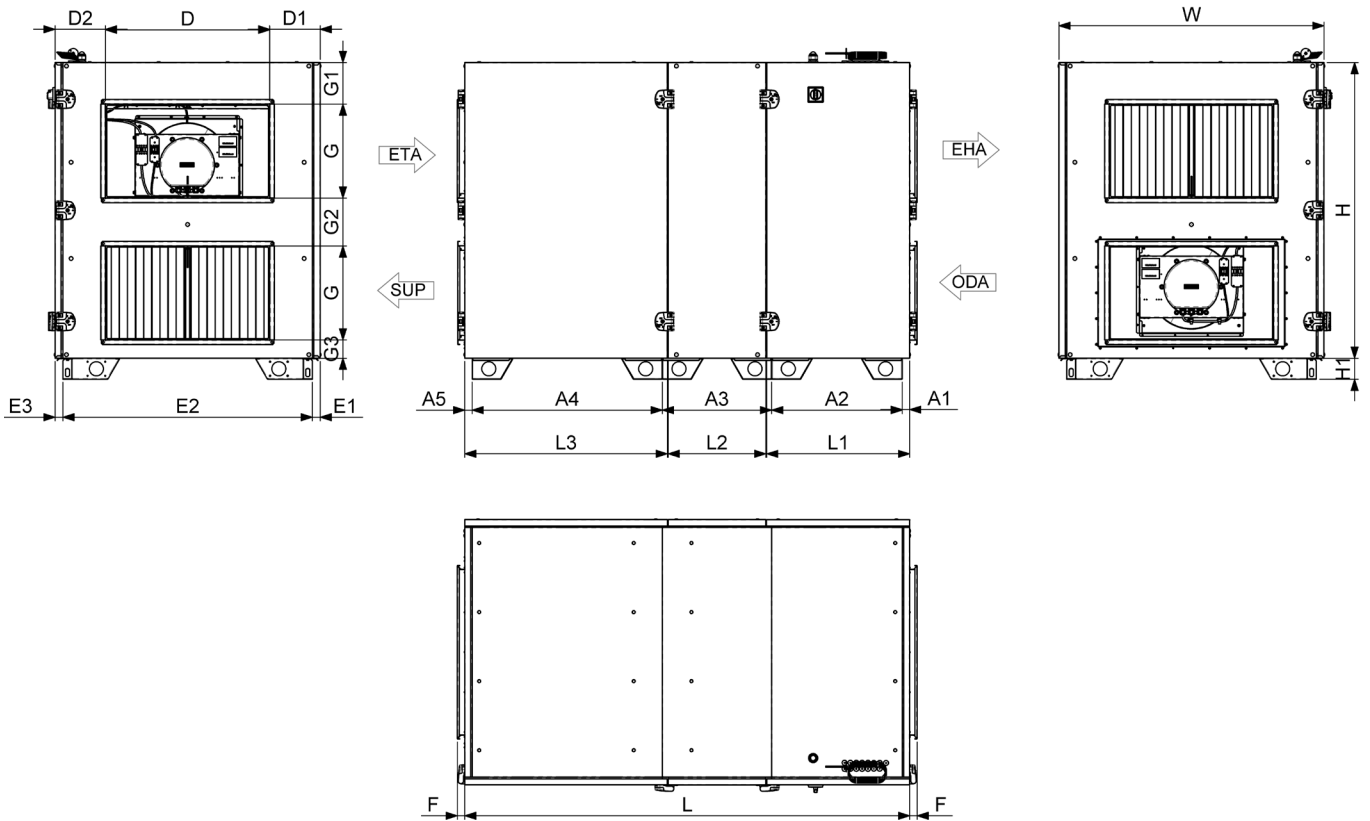

Fig. 8.1.13 AmberAir Compact S-R-3000-H-E-L-C1 / AmberAir Compact S-R-4000-H-E-L-C1 / AmberAir Compact S-R-5000-H-E-L-C1 dimensions

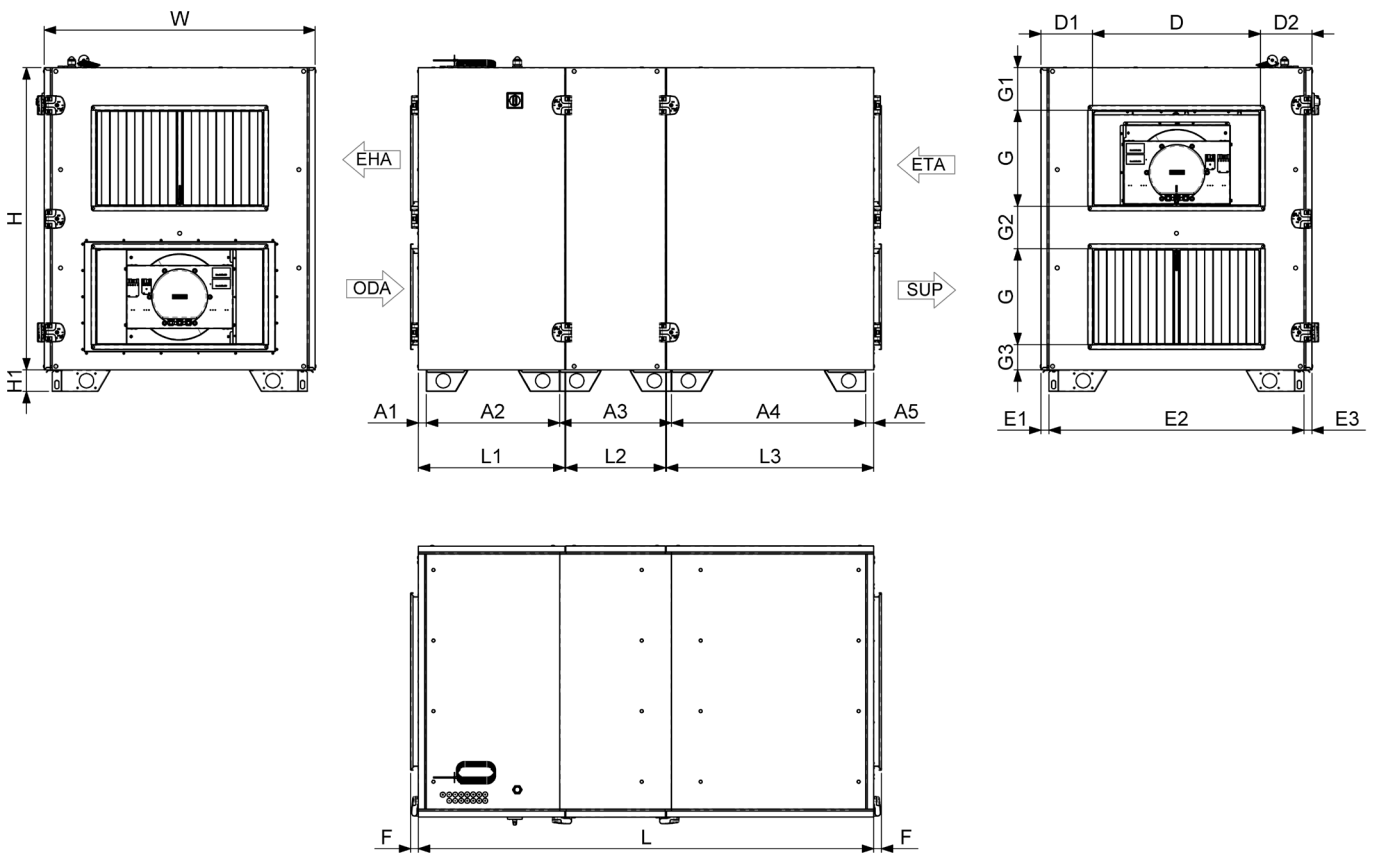
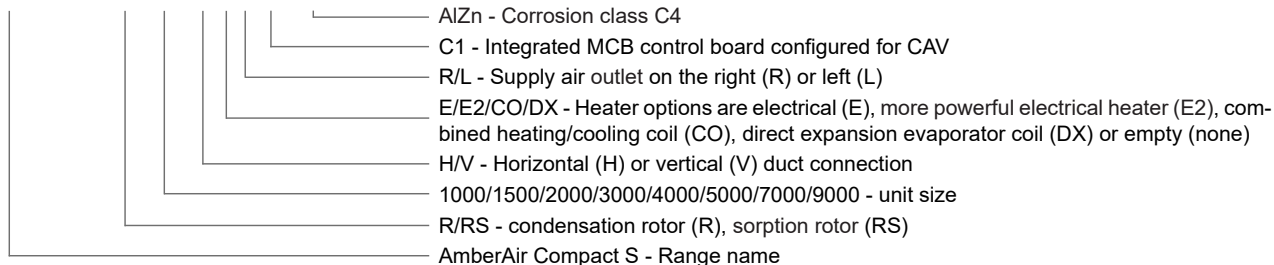

Fig. 8.1.14 AmberAir Compact S-R-3000-H-E-R-C1 / AmberAir Compact S-R-4000-H-E-R-C1 / AmberAir Compact S-R-5000-H-E-R-C1 dimensions

AMBERAIR COMPACT S-R/RS		3000- H-L-C1	3000- H-E-L-C1	3000- H-R-C1	3000- H-E-R-C1	4000- H-L-C1	4000- H-E-L-C1	4000- H-R-C1	4000- H-E-R-C1	5000- H-L-C1	5000- H-E-L-C1	5000- H-R-C1	5000- H-E-R-C1
L	[mm]	1 900				2 000				1 900			
W	[mm]	1 130				1 280				1 370			
H	[mm]	1 260				1 400				1 490			
D	[mm]	700				800				1 000			
G	[mm]	400								500			
L1	[mm]	610				723				621			
L2	[mm]	416											
L3	[mm]	864				853				855			
F	[mm]	32				31							
H1	[mm]	90											
A1	[mm]	33				32				33			
A2	[mm]	557				670				567			
A3	[mm]	466											
A4	[mm]	811				800				801			
A5	[mm]	33				32				33			
D1	[mm]	215				240				185			
D2	[mm]	215				240				185			
E1	[mm]	33											
E2	[mm]	1 064				1 214				1 304			
E3	[mm]	33											
G1	[mm]	177				203				172			
G2	[mm]	205				273				240			
G3	[mm]	78				125				78			
WEIGHT	[kg]	357	364	357	364	459	465	459	465	472	480	472	480
INSULATION THICKNESS	[mm]	50											

AmberAir Compact S-R-1500-H-E-R-C1 AlZn



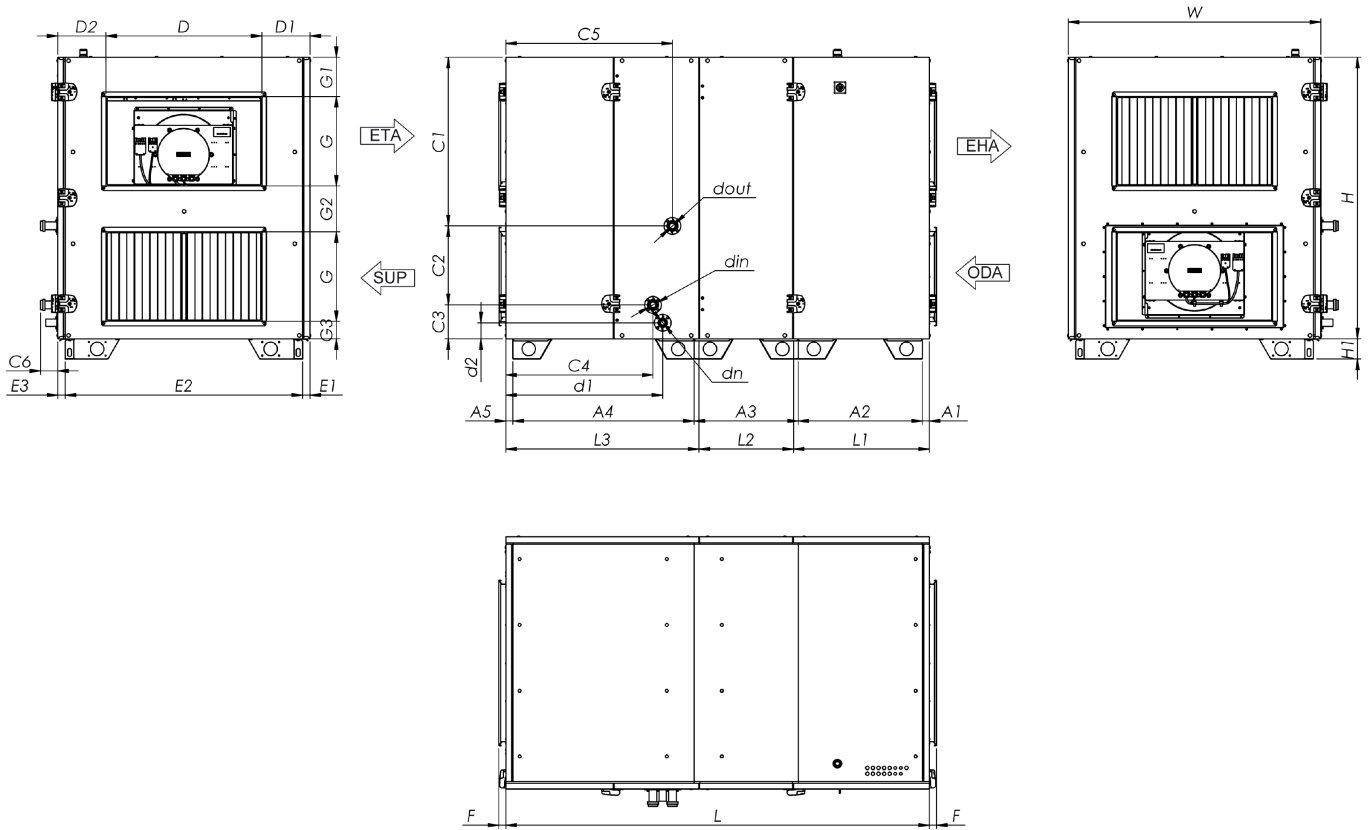

Fig. 8.1.15 AmberAir Compact S-R-3000-H-CO-L-C1 / AmberAir Compact S-R-4000-H-CO-L-C1 / AmberAir Compact S-R-5000-H-CO-L-C1 dimensions

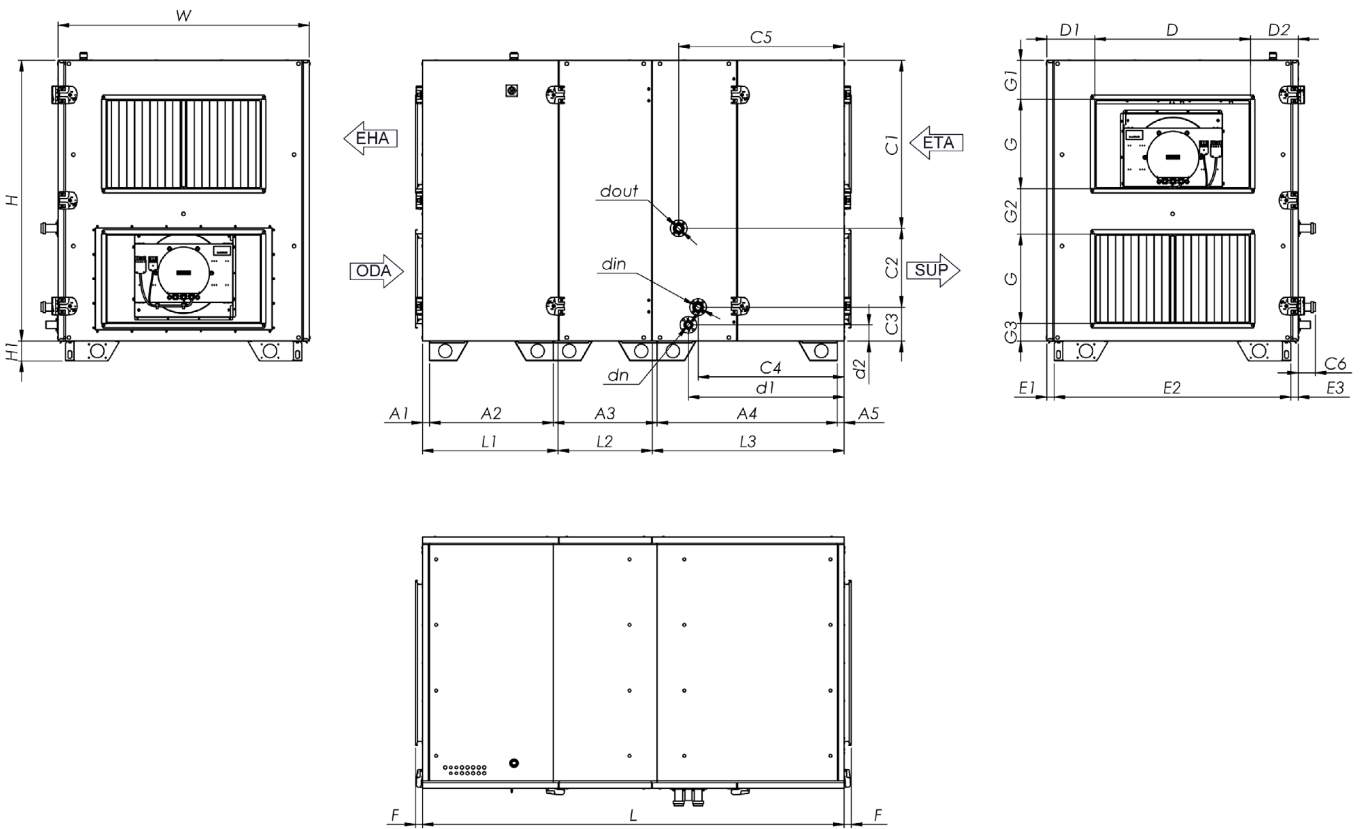
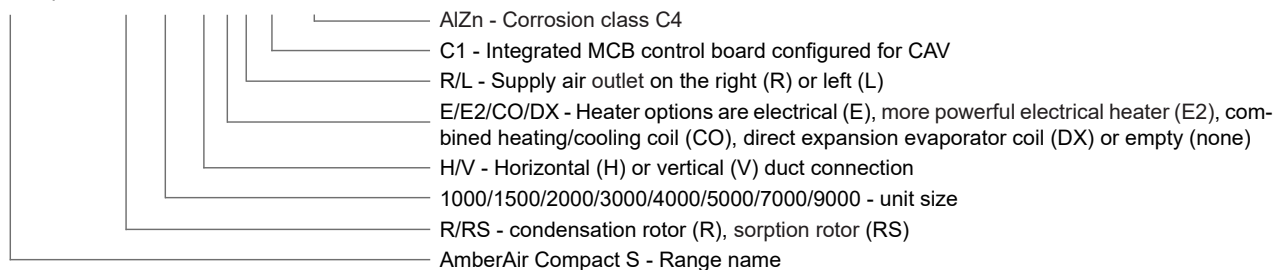

Fig. 8.1.16 AmberAir Compact S-R-3000-H-CO-R-C1 / AmberAir Compact S-R-4000-H-CO-R-C1 / AmberAir Compact S-R-5000-H-CO-R-C1 dimensions

AMBERAIR COMPACT S-R/RS		3000- H-CO-L-C1	3000- H-CO-R-C1	4000- H-CO-L-C1	4000- H-CO-R-C1	5000- H-CO-L-C1	5000- H-CO-R-C1
L	[mm]	1 900		2 000		1 900	
W	[mm]	1 130		1 280		1 370	
H	[mm]	1 260		1 400		1 490	
D	[mm]	700		800		1 000	
G	[mm]	400				500	
L1	[mm]	610		723		621	
L2	[mm]	416					
L3	[mm]	864		853		855	
dn		32					
F	[mm]	32		31			
H1	[mm]	90					
A1	[mm]	33		32		33	
A2	[mm]	557		670		567	
A3	[mm]	466					
A4	[mm]	811		800		801	
A5	[mm]	33		32		33	
C1	[mm]	755		823		888	
C2	[mm]	353		419		447	
C3	[mm]	152		157		155	
C4	[mm]	659		663		650	
C5	[mm]	746		720		737	
C6	[mm]	77		78			
D1	[mm]	215		240		185	
D2	[mm]	215		240		185	
din		1-1/4"				1-1/2"	
dout		1-1/4"				1-1/2"	
E1	[mm]	33					
E2	[mm]	1 064		1 214		1 304	
E3	[mm]	33					
G1	[mm]	177		203		172	
G2	[mm]	205		273		240	
G3	[mm]	78		125		78	
d1	[mm]	702		692		694	
d2	[mm]	72		74		68	
WEIGHT	[kg]	378		484		505	
INSULATION THICKNESS	[mm]	50					

AmberAir Compact S-R-1500-H-E-R-C1 AlZn



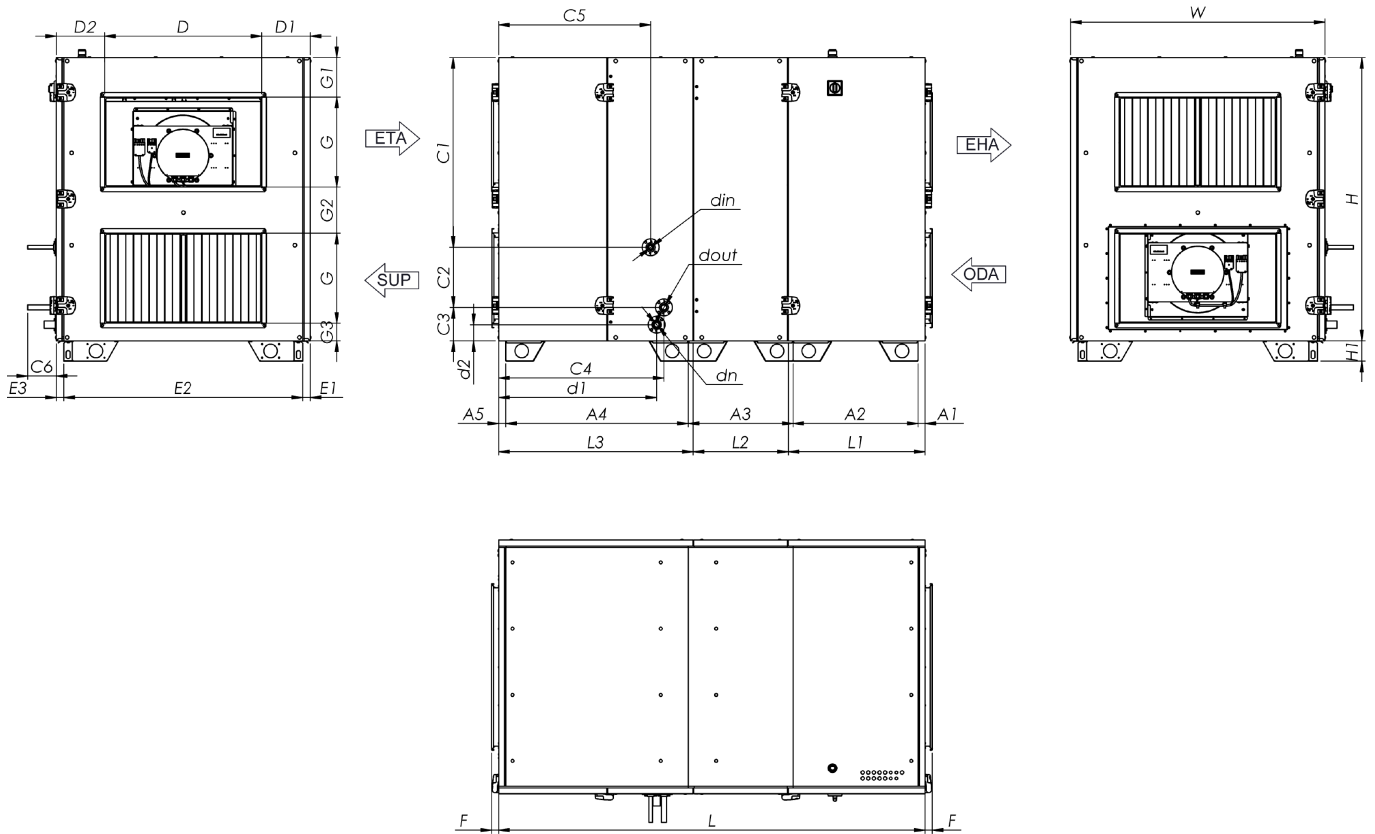

Fig. 8.1.17 AmberAir Compact S-R-3000-H-DX-L-C1 / AmberAir Compact S-R-4000-H-DX-L-C1 / AmberAir Compact S-R-5000-H-DX-L-C1 dimensions

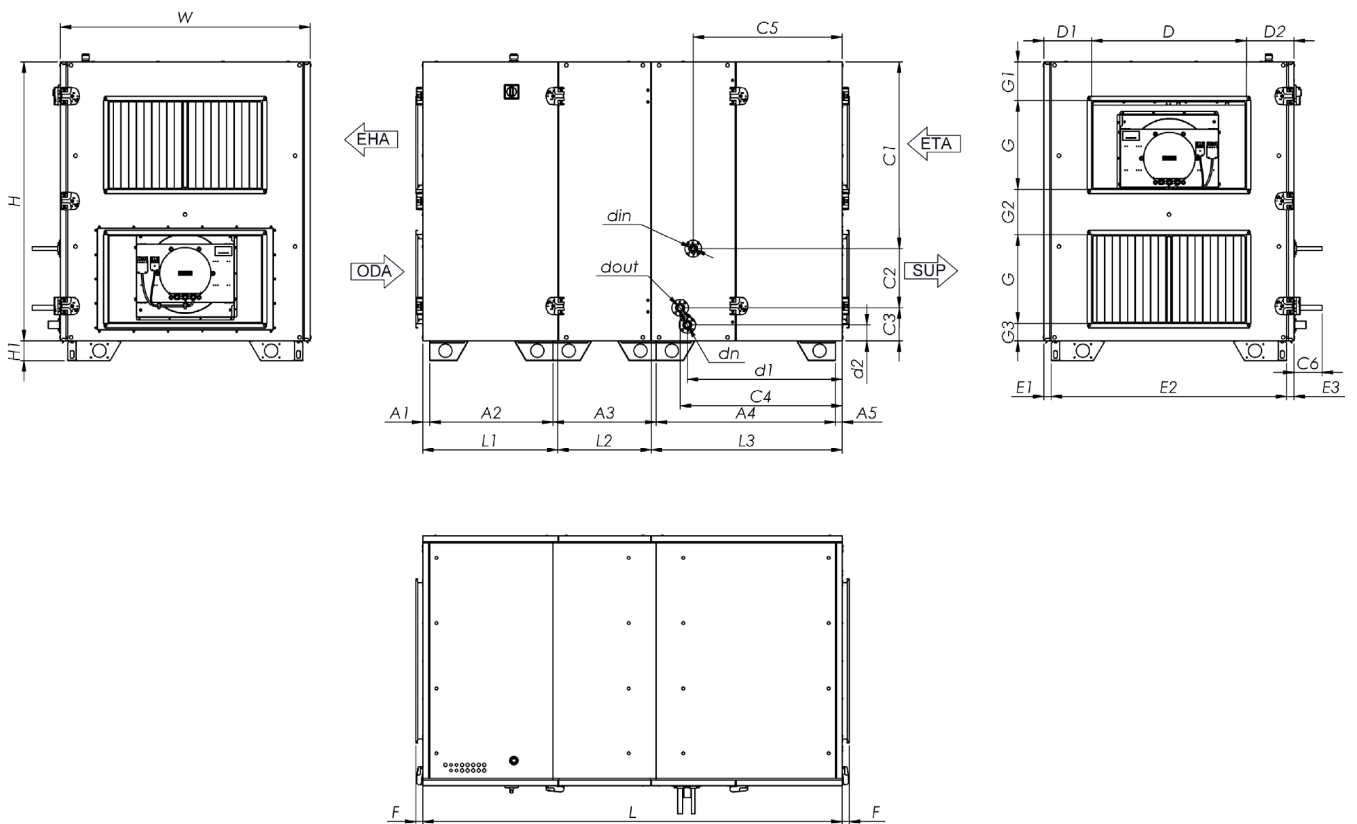
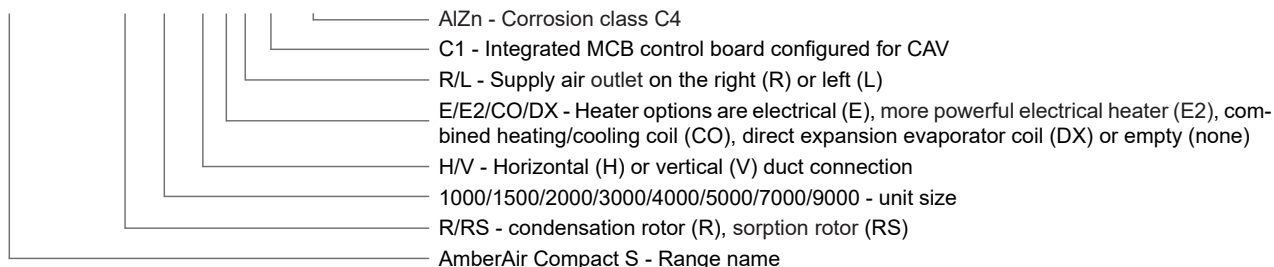

Fig. 8.1.18 AmberAir Compact S-R-3000-H-DX-R-C1 / AmberAir Compact S-R-4000-H-DX-R-C1 / AmberAir Compact S-R-5000-H-DX-R-C1 dimensions

AMBERAIR COMPACT S-R/RS		3000-H-DX-L-C1	3000-H-DX-R-C1	4000-H-DX-L-C1	4000-H-DX-R-C1	5000-H-DX-L-C1	5000-H-DX-R-C1
L	[mm]	1 900		2 000		1 900	
W	[mm]	1 130		1 280		1 370	
H	[mm]	1 260		1 400		1 490	
D	[mm]	700		800		1 000	
G	[mm]	400				500	
L1	[mm]	610		723		621	
L2	[mm]	416					
L3	[mm]	864		853		855	
dn		32					
F	[mm]	32		31			
H1	[mm]	90					
A1	[mm]	33		32		33	
A2	[mm]	557		670		567	
A3	[mm]	466					
A4	[mm]	811		800		801	
A5	[mm]	33		32		33	
C1	[mm]	844		953		1 010	
C2	[mm]	267		270		316	
C3	[mm]	149		177		164	
C4	[mm]	735		724		726	
C5	[mm]	678		681		683	
C6	[mm]	127		58		58	
D1	[mm]	215		240		185	
D2	[mm]	215		240		185	
din	[mm]	16					
dout	[mm]	22				28	
E1	[mm]	33					
E2	[mm]	1 064		1 214		1 304	
E3	[mm]	33					
G1	[mm]	177		203		172	
G2	[mm]	205		273		240	
G3	[mm]	78		125		78	
d1	[mm]	702		692		694	
d2	[mm]	72		74		68	
WEIGHT	[kg]	378		481		500	
INSULATION THICKNESS	[mm]	50					

AmberAir Compact S-R-1500-H-E-R-C1 AlZn



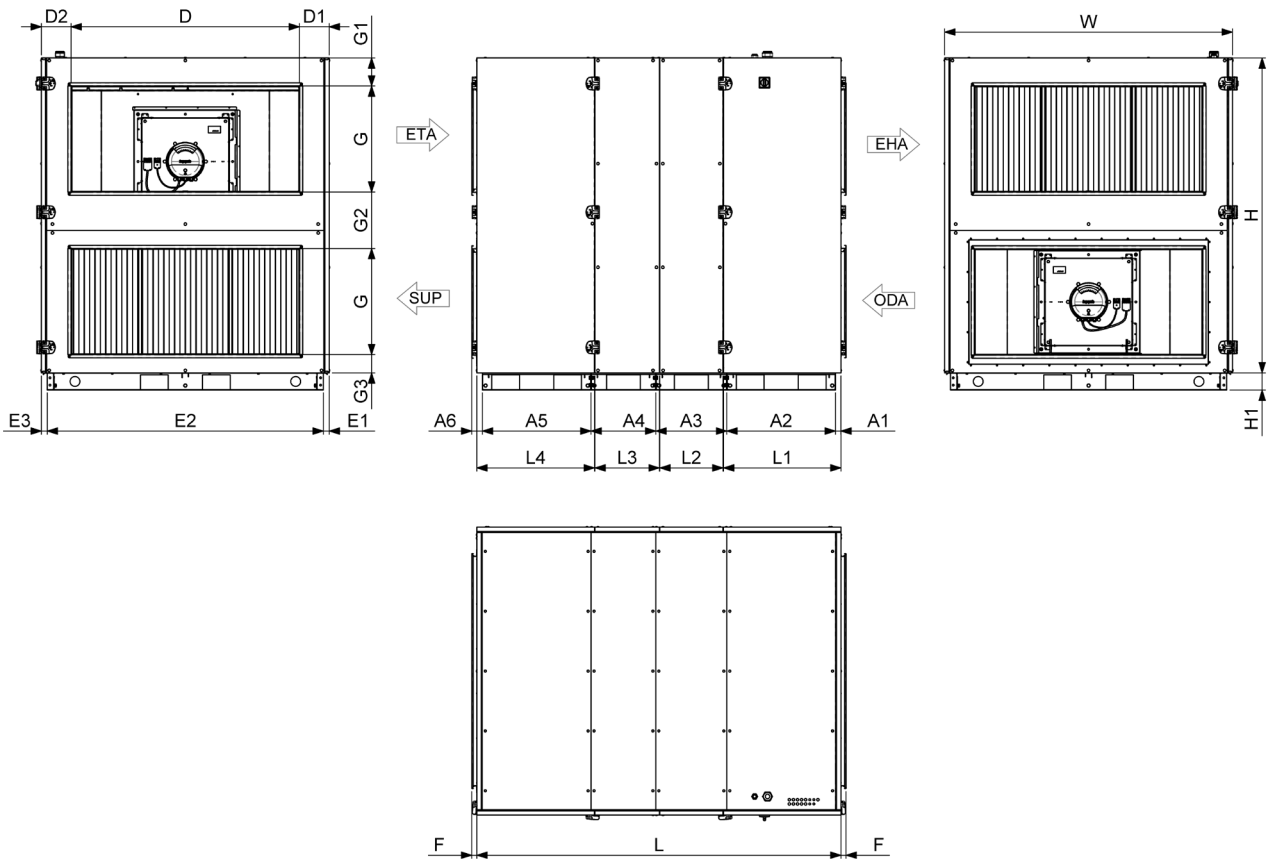

Fig. 8.1.19 AmberAir Compact S-R-7000-H-E-L-C1 / AmberAir Compact S-R-9000-H-E-L-C1 dimensions

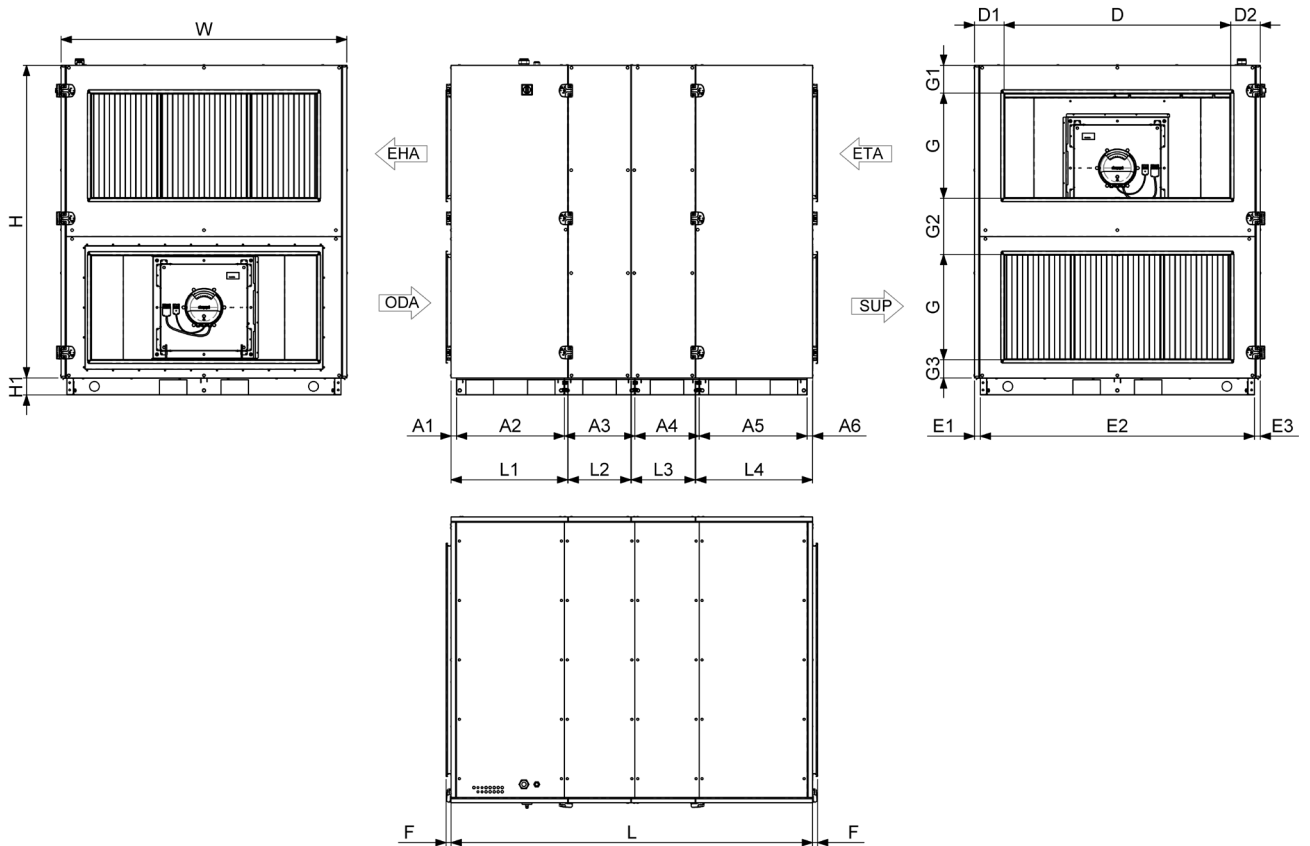
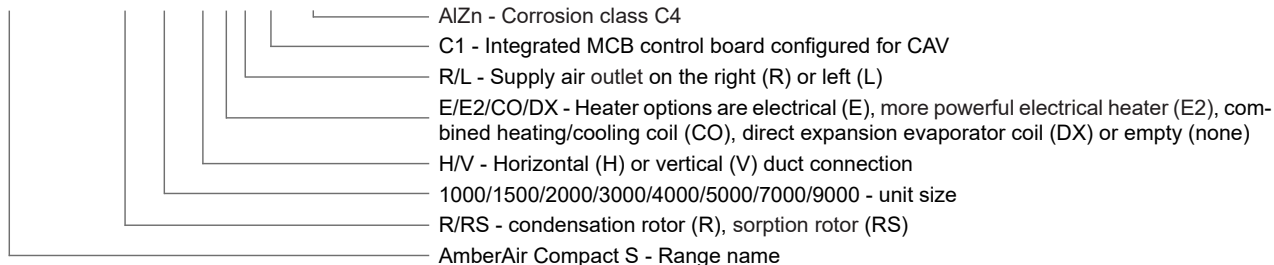

Fig. 8.1.20 AmberAir Compact S-R-7000-H-E-R-C1 / AmberAir Compact S-R-9000-H-E-R-C1 dimensions

AMBERAIR COMPACT S-R/RS		7000-H-L-C1	7000-H-E-L-C1	7000-H-R-C1	7000-H-E-R-C1	9000-H-L-C1	9000-H-E-L-C1	9000-H-R-C1	9000-H-E-R-C1
L	[mm]	2 272				2 232			
W	[mm]	1 590				1 765			
H	[mm]	1 750				1 930			
D	[mm]	1 200				1 400			
G	[mm]	600				650			
L1	[mm]	730				720			
L2	[mm]	416				387			
L3	[mm]	398				393			
L4	[mm]	716				721			
F	[mm]					31			
H1	[mm]	105				105			
A1	[mm]					33			
A2	[mm]	676				666			
A3	[mm]	466				435			
A4	[mm]	400				397			
A5	[mm]	664				666			
A6	[mm]					33			
D1	[mm]	195				183			
D2	[mm]	195				183			
E1	[mm]					36			
E2	[mm]	1 518				1 693			
E3	[mm]					36			
G1	[mm]					172			
G2	[mm]	266				346			
G3	[mm]					112			
WEIGHT	[kg]	700	710	700	710	824	835	824	835
INSULATION THICKNESS	[mm]	50							

AmberAir Compact S-R-1500-H-E-R-C1 AlZn



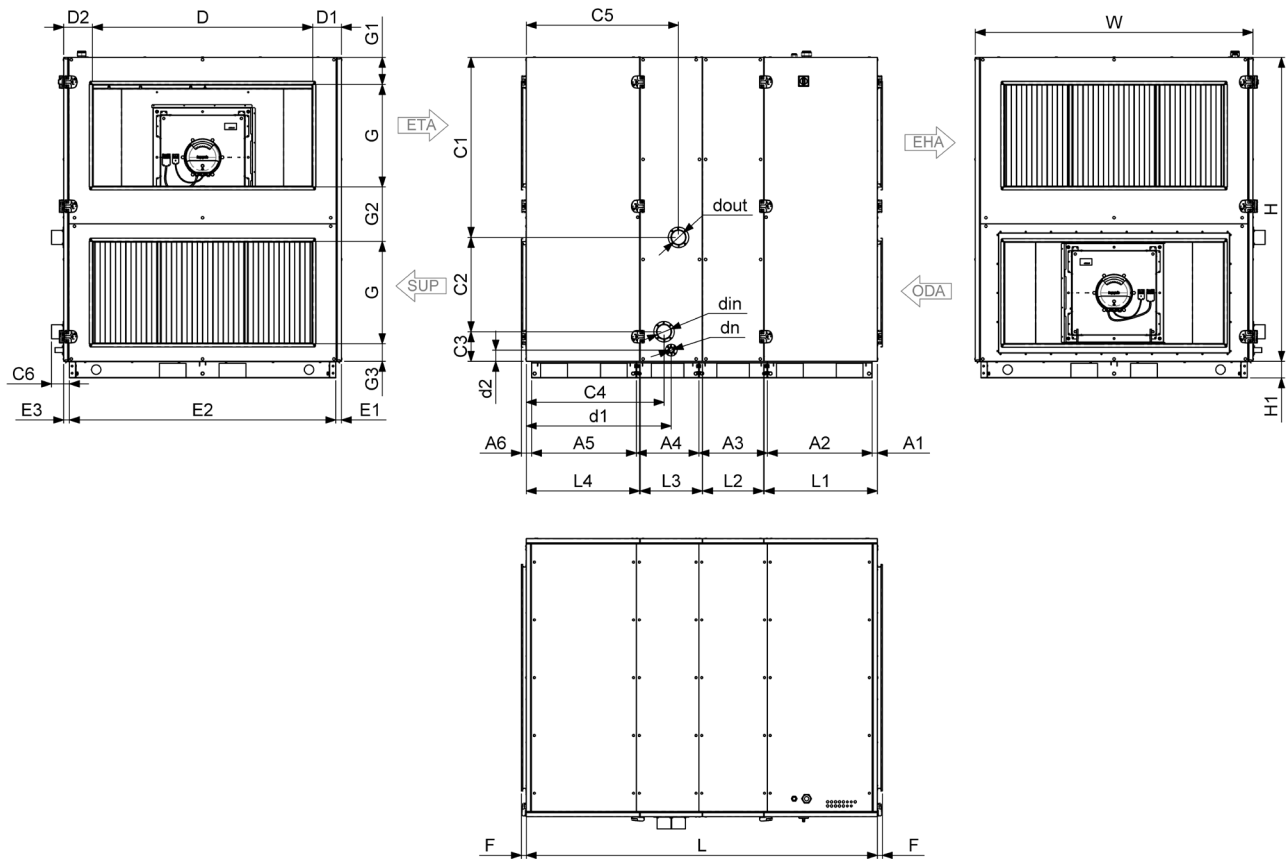

Fig. 8.1.21 AmberAir Compact S-R-7000-H-CO-L-C1 / AmberAir Compact S-R-9000-H-CO-L-C1 dimensions

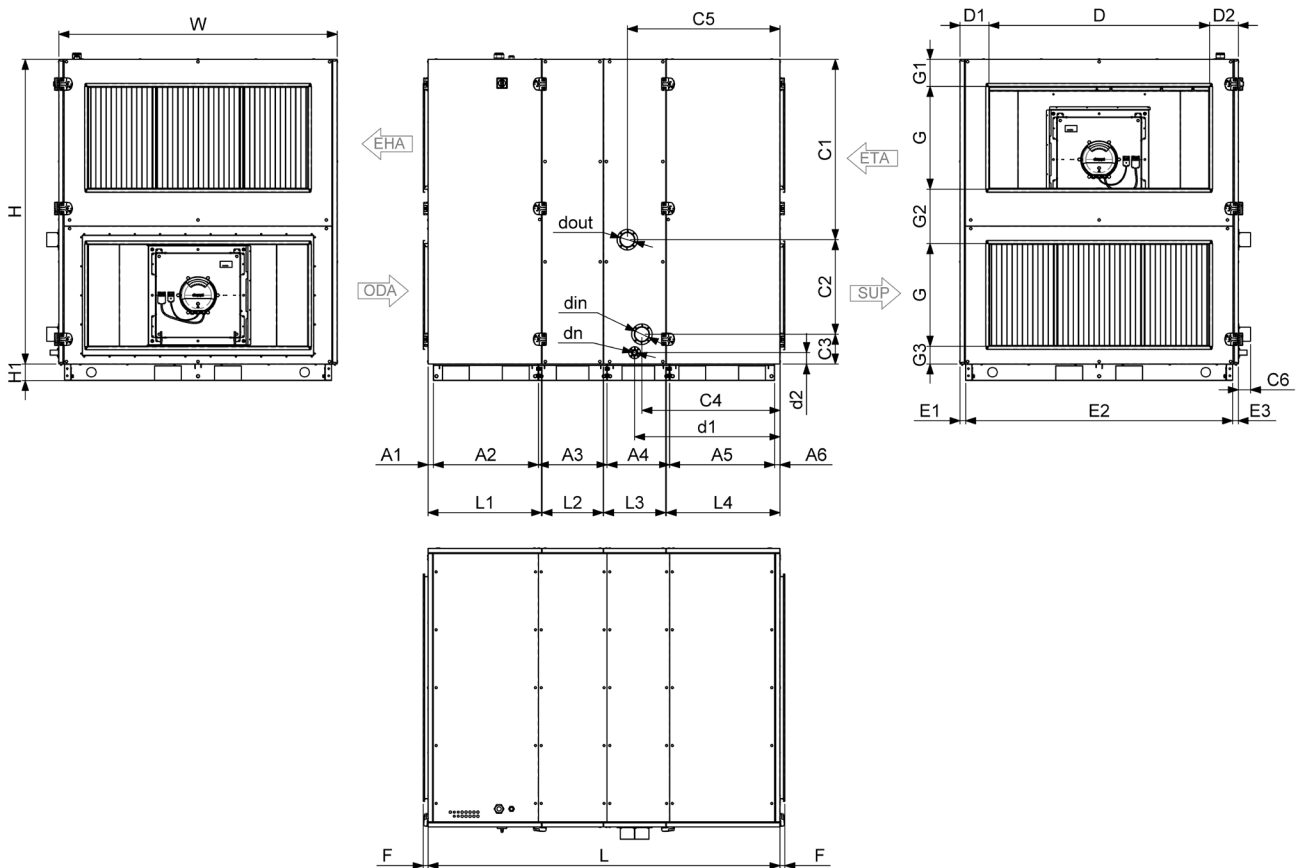
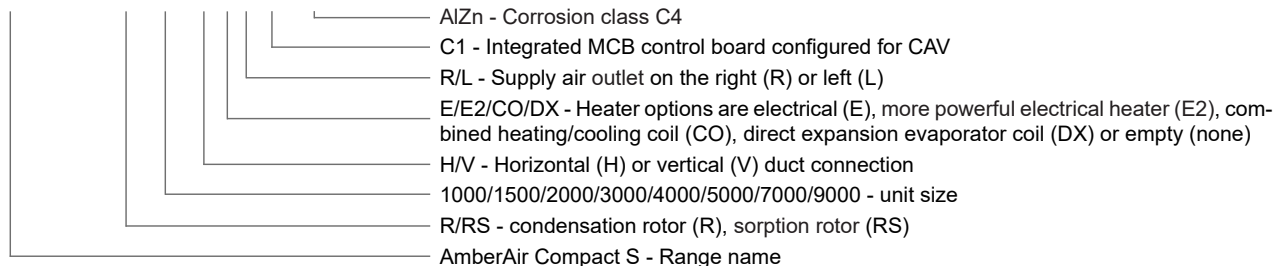

Fig. 8.1.22 AmberAir Compact S-R-7000-H-CO-R-C1 / AmberAir Compact S-R-9000-H-CO-R-C1 dimensions

AMBERAIR COMPACT S-R/RS		7000-H-CO-L-C1	7000-H-CO-R-C1	9000-H-CO-L-C1	9000-H-CO-R-C1
L	[mm]	2 272		2 232	
W	[mm]	1 590		1 765	
H	[mm]	1 750		1 930	
D	[mm]	1 200		1 400	
G	[mm]	600		650	
L1	[mm]	730		720	
L2	[mm]	416		387	
L3	[mm]	398		393	
L4	[mm]	716		721	
dn		32			
F	[mm]	31			
H1	[mm]	105			
A1	[mm]	33			
A2	[mm]	676		666	
A3	[mm]	466		435	
A4	[mm]	400		397	
A5	[mm]	664		666	
A6	[mm]	33			
C1	[mm]	1 006		1 143	
C2	[mm]	580		599	
C3	[mm]	164		188	
C4	[mm]	892		877	
C5	[mm]	949		968	
C6	[mm]	77			
D1	[mm]	195		183	
D2	[mm]	195		183	
din		1-1/2"			
dout		1-1/2"			
E1	[mm]	36			
E2	[mm]	1 518		1 693	
E3	[mm]	36			
G1	[mm]	172			
G2	[mm]	266		346	
G3	[mm]	112			
d1	[mm]	920		923	
d2	[mm]	74		71	
WEIGHT	[kg]	745		904	
INSULATION THICKNESS	[mm]	50			

AmberAir Compact S-R-1500-H-E-R-C1 AlZn



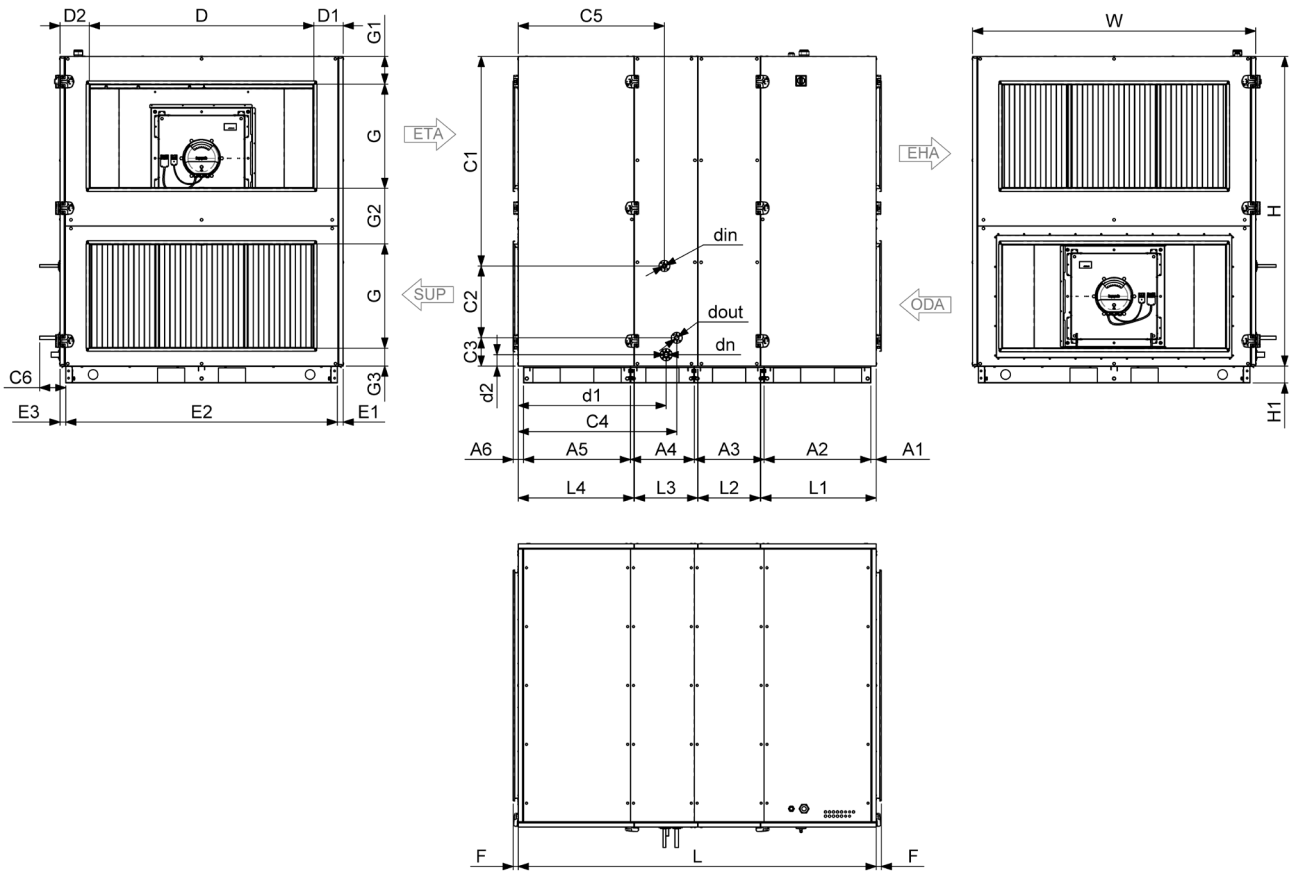

Fig. 8.1.23 AmberAir Compact S-R-7000-H-DX-L-C1 / AmberAir Compact S-R-9000-H-DX-L-C1 dimensions

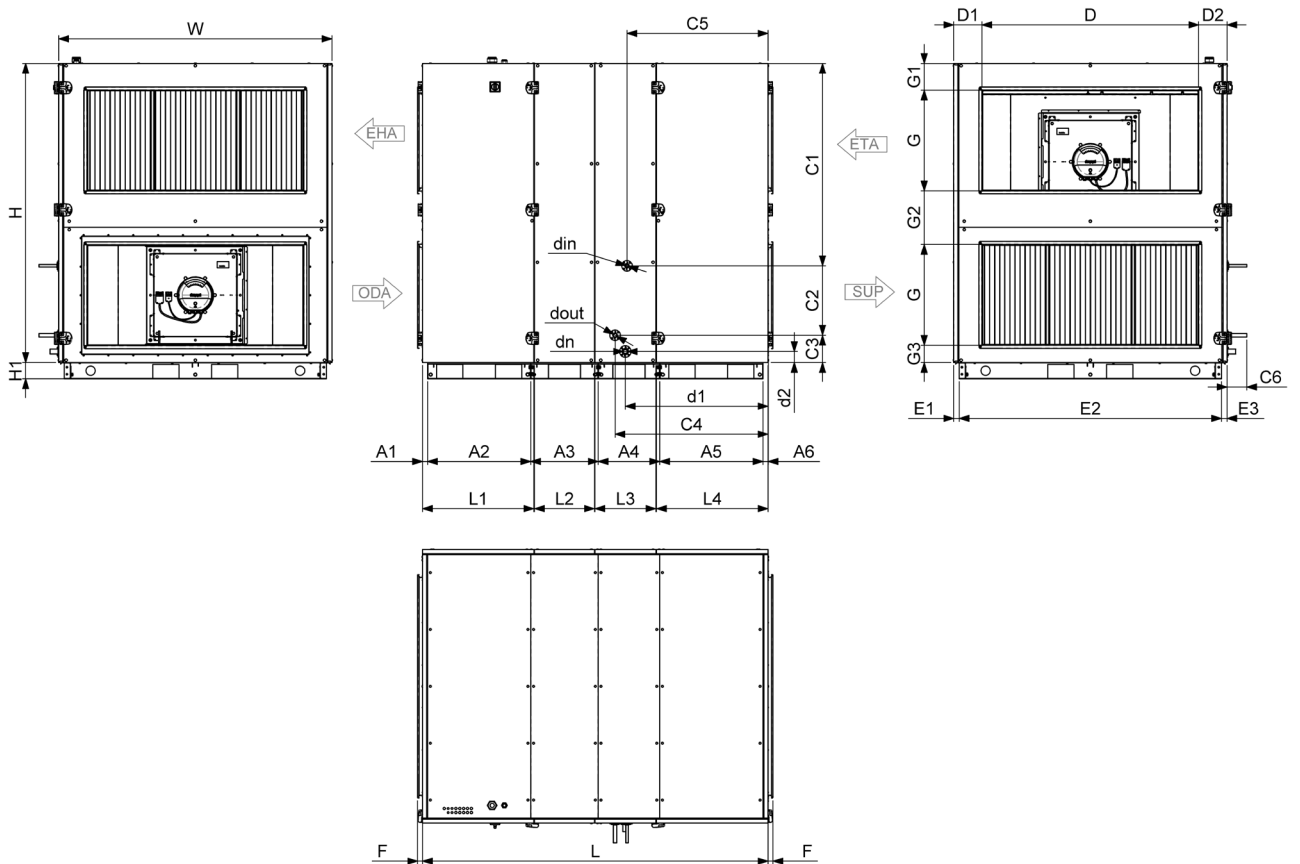
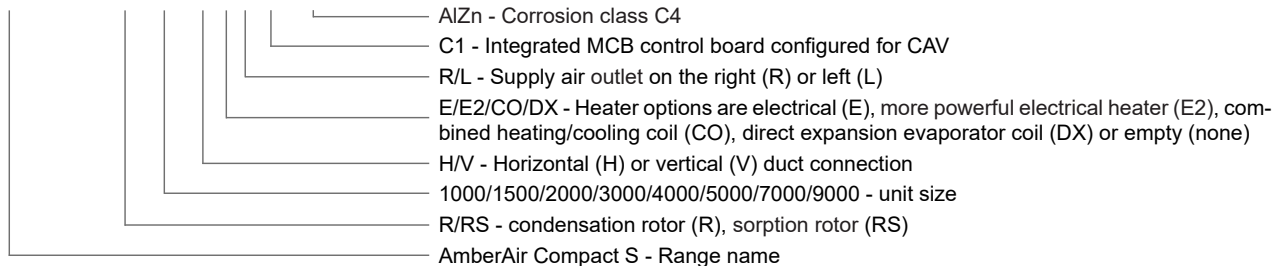

Fig. 8.1.24 AmberAir Compact S-R-7000-H-DX-R-C1 / AmberAir Compact S-R-9000-H-DX-R-C1 dimensions

AMBERAIR COMPACT S-R/RS		7000- H-DX-L-C1	7000- H-DX-R-C1	9000- H-DX-L-C1	9000- H-DX-R-C1
L	[mm]	2 272		2 232	
W	[mm]	1 590		1 765	
H	[mm]	1 750		1 930	
D	[mm]	1 200		1 400	
G	[mm]	600		650	
L1	[mm]	730		720	
L2	[mm]	416		387	
L3	[mm]	398		393	
L4	[mm]	716		721	
dn		32			
F	[mm]	31			
H1	[mm]	105			
A1	[mm]	33			
A2	[mm]	676		666	
A3	[mm]	466		435	
A4	[mm]	400		397	
A5	[mm]	664		666	
A6	[mm]	33			
C1	[mm]	1 177		1 306	
C2	[mm]	394		448	
C3	[mm]	179		176	
C4	[mm]	955		988	
C5	[mm]	926		911	
C6	[mm]	57		58	
D1	[mm]	195		183	
D2	[mm]	195		183	
din	[mm]	16		22	
dout	[mm]	29		35	
E1	[mm]	36			
E2	[mm]	1 518		1 693	
E3	[mm]	36			
G1	[mm]	172			
G2	[mm]	266		346	
G3	[mm]	112			
d1	[mm]	920		923	
d2	[mm]	74		71	
WEIGHT	[kg]	738		880	
INSULATION THICKNESS	[mm]	50			

AmberAir Compact S-R-1500-H-E-R-C1 AlZn



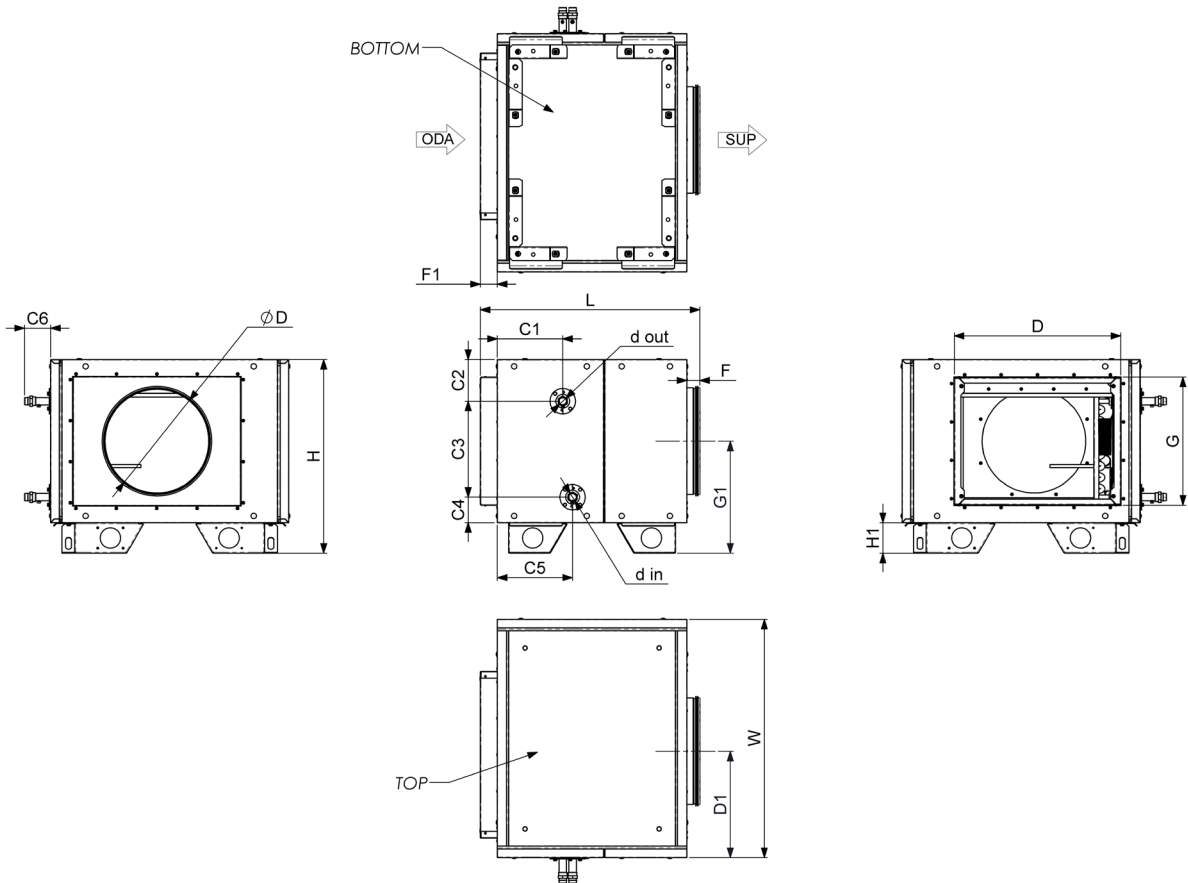

Fig. 8.1.25 Comfort box WH right for AmberAir Compact S-R-1000-H / AmberAir Compact S-R-1500-H / AmberAir Compact S-R-2000-H dimensions

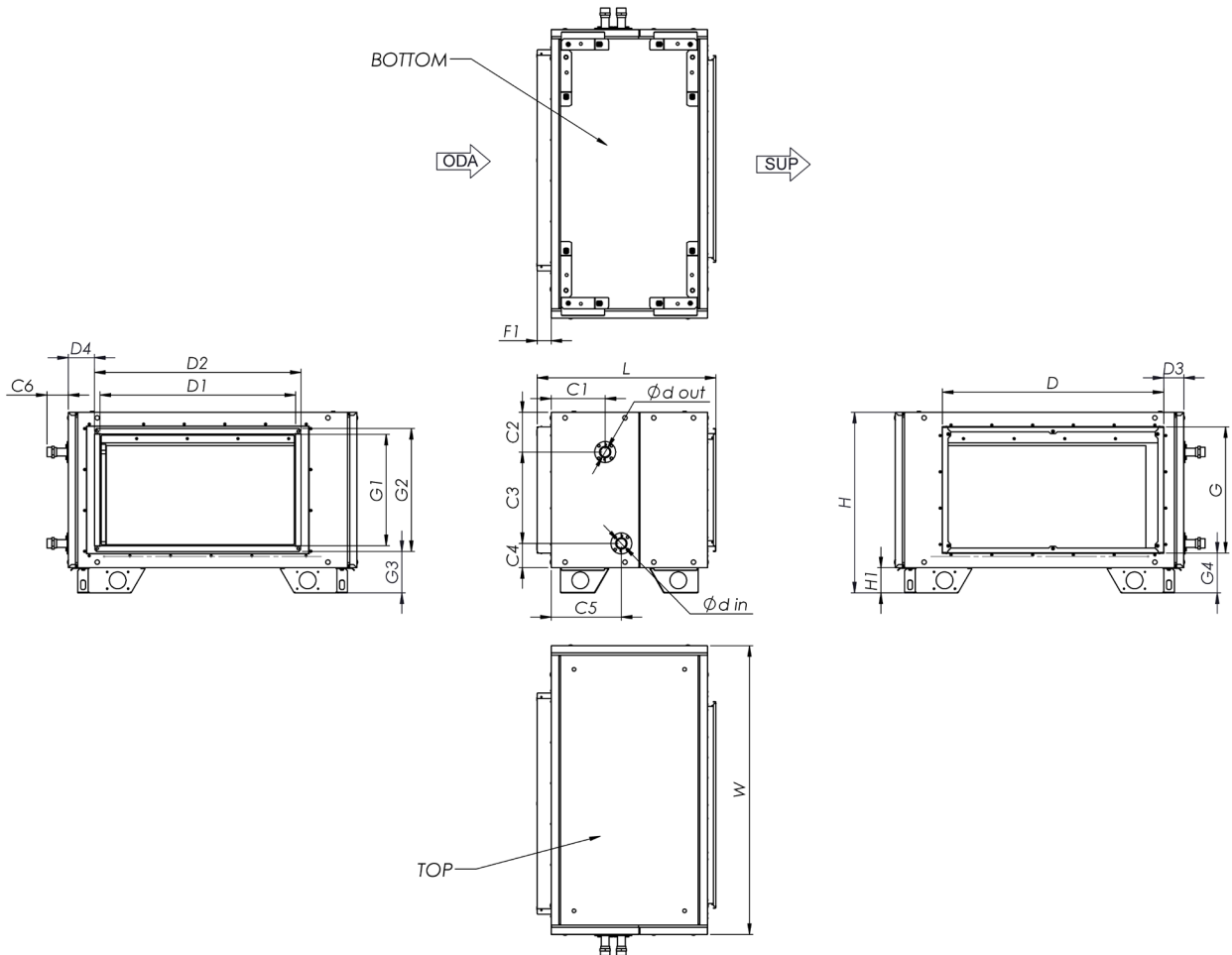

Fig. 8.1.26 Comfort box WH right for AmberAir Compact S-R-3000-H dimensions

Comfort box WH right for AmberAir Compact-S-R H		1000	1500	2000	3000
L	[mm]	650	655	680	640
W	[mm]	704	754	854	1 033
H	[mm]	572	600	650	
ØD	[mm]	315	355	400	-
D	[mm]	492	538	638	792
G	[mm]	378	402	452	
F	[mm]	39	43	68	30
F1	[mm]	50			
H1	[mm]	90			
C1	[mm]	193			
C2	[mm]	123	114	140	143
C3	[mm]	283	317	333	327
C4	[mm]	76		84	87
C5	[mm]	222		251	
C6	[mm]	77			
D1	[mm]	314	339	389	700
D2	[mm]	-			
D3	[mm]	-			
D4	[mm]	-			
din		1/2"		3/4"	1"
dout		1/2"		3/4"	1"
G1	[mm]	331	343	368	400
G2	[mm]	-			
G3	[mm]	-			
G4	[mm]	-			
WEIGHT	[kg]	33	48	63	75
INSULATION THICKNESS	[mm]	50			

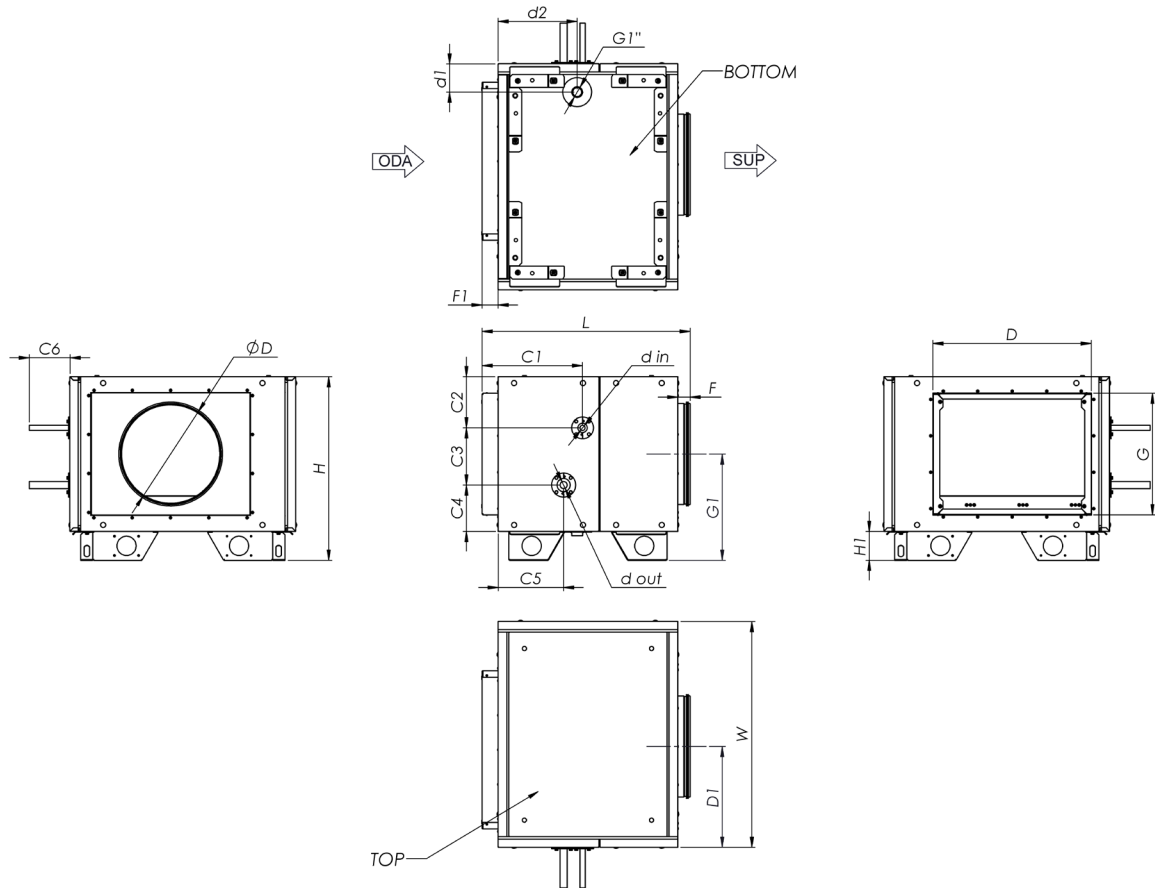

Fig. 8.1.27 Comfort box DX right for AmberAir Compact-S-R-1000-H / AmberAir Compact S-R-1500-H / AmberAir Compact S-R-2000-H dimensions

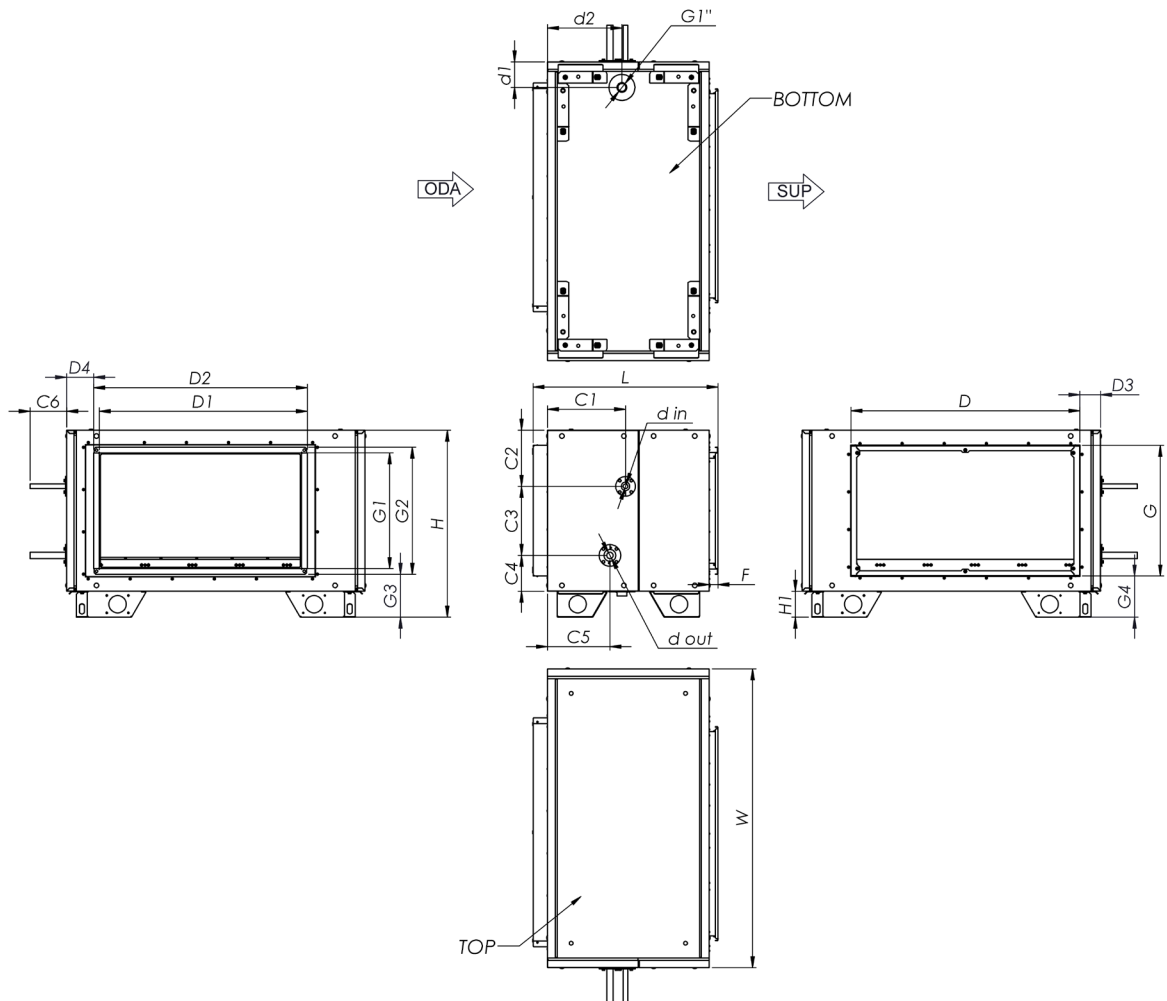

Fig. 8.1.28 Comfort box DX right for AmberAir Compact S-R-3000-H dimensions

Comfort box DX right for AmberAir Compact-S-R H		1000	1500	2000	3000
L	[mm]	650	655	680	640
W	[mm]	704	754	854	1 033
H	[mm]	572	600	650	
ØD	[mm]	315	355	400	-
D	[mm]	492	538	638	792
G	[mm]	378	402	452	
F	[mm]	39	43	68	30
F1	[mm]	50			
H1	[mm]	90			
C1	[mm]	313	265	320	270
C2	[mm]	159	174	192	194
C3	[mm]	178	201	243	239
C4	[mm]	144	132	121	124
C5	[mm]	204	194	216	
C6	[mm]	127			
D1	[mm]	314	339	389	700
D2	[mm]	-			
D3	[mm]	-			
D4	[mm]	-			
din	[mm]	12	16		
dout	[mm]	12	22		
G1	[mm]	331	343	368	400
G2	[mm]	-			
G3	[mm]	-			
G4	[mm]	-			
d1	[mm]	88			
d2	[mm]	246	252	258	
WEIGHT	[kg]	64	79	86	101
INSULATION THICKNESS	[mm]	50			

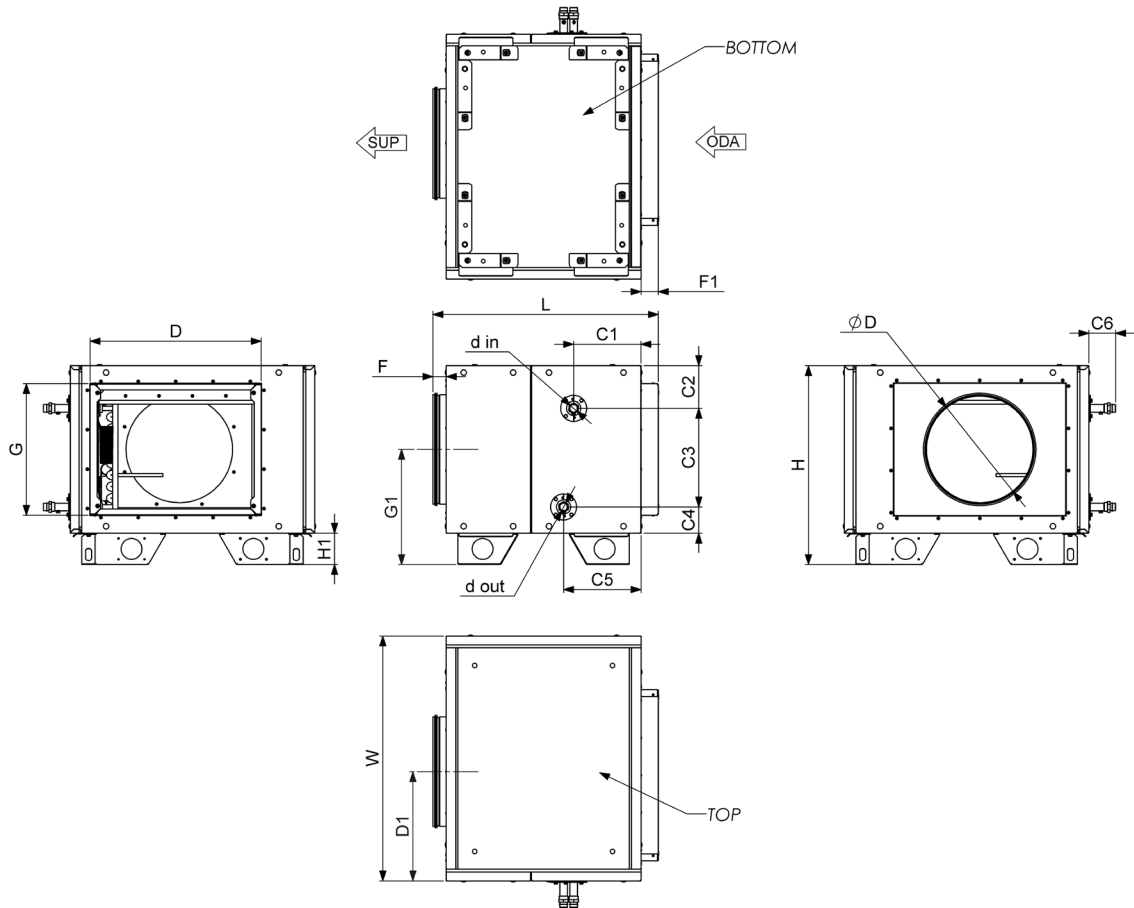

Fig. 8.1.29 Comfort box WH left for AmberAir Compact-S-R-1000-H / AmberAir Compact S-R-1500-H / AmberAir Compact S-R-2000-H dimensions

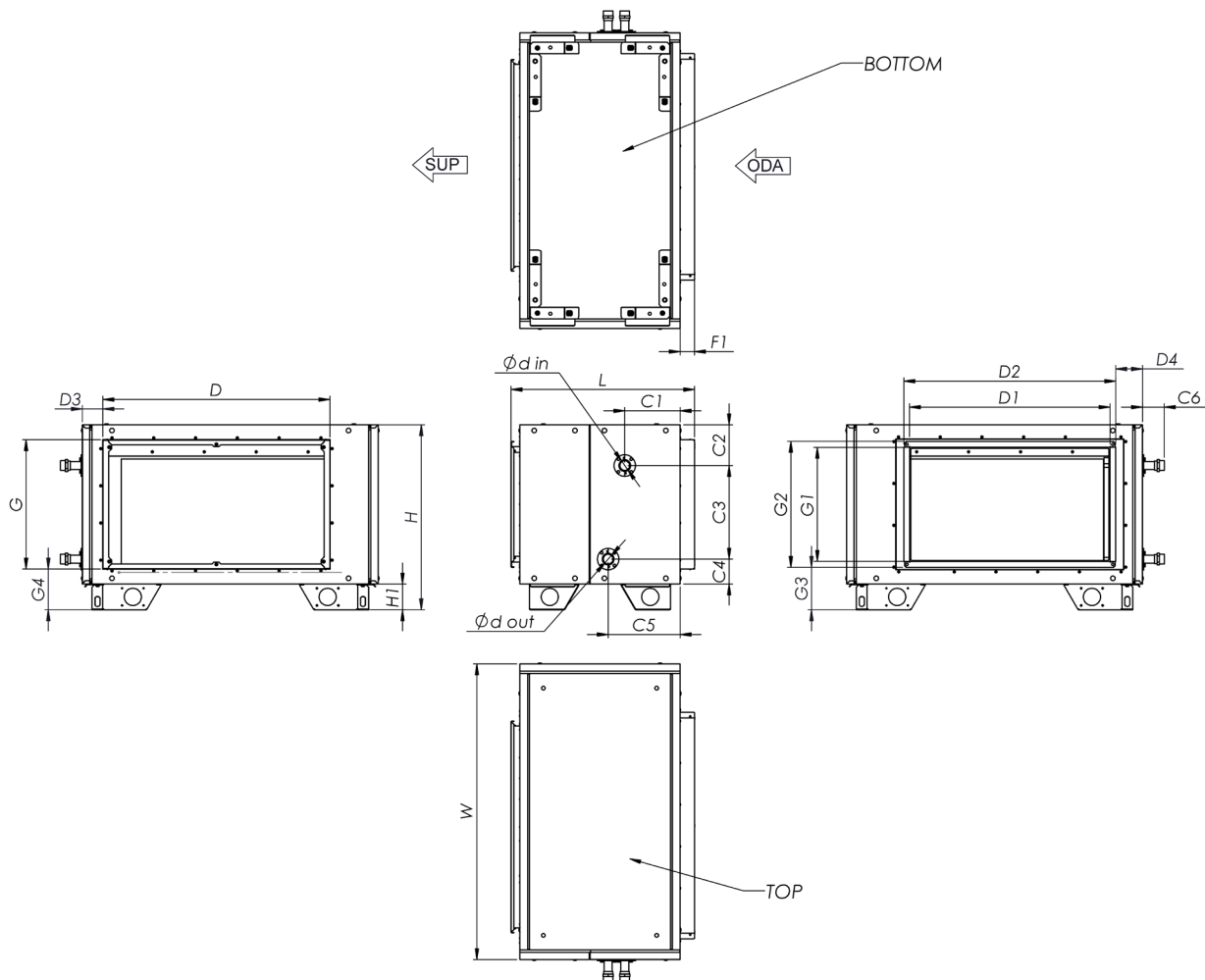

Fig. 8.1.30 Comfort box WH left for AmberAir Compact S-R-3000-H dimensions

Comfort box WH left for AmberAir Compact-S-R H		1000	1500	2000	3000
L	[mm]	650	655	680	640
W	[mm]	704	754	854	1 033
H	[mm]	572	600	650	
ØD	[mm]	315	355	400	-
D	[mm]	492	538	638	792
G	[mm]	378	402	452	
F	[mm]	39	43	68	30
F1	[mm]	50			
H1	[mm]	90			
C1	[mm]	193			
C2	[mm]	123	114	140	143
C3	[mm]	283	317	333	327
C4	[mm]	76		84	87
C5	[mm]	222		251	
C6	[mm]	77			
D1	[mm]	314	339	389	700
D2	[mm]	-			
D3	[mm]	-			
D4	[mm]	-			
din		1/2"		3/4"	1"
dout		1/2"		3/4"	1"
G1	[mm]	331	343	368	400
G2	[mm]	-			
G3	[mm]	-			
G4	[mm]	-			
WEIGHT	[kg]	33	48	63	75
INSULATION THICKNESS	[mm]	50			

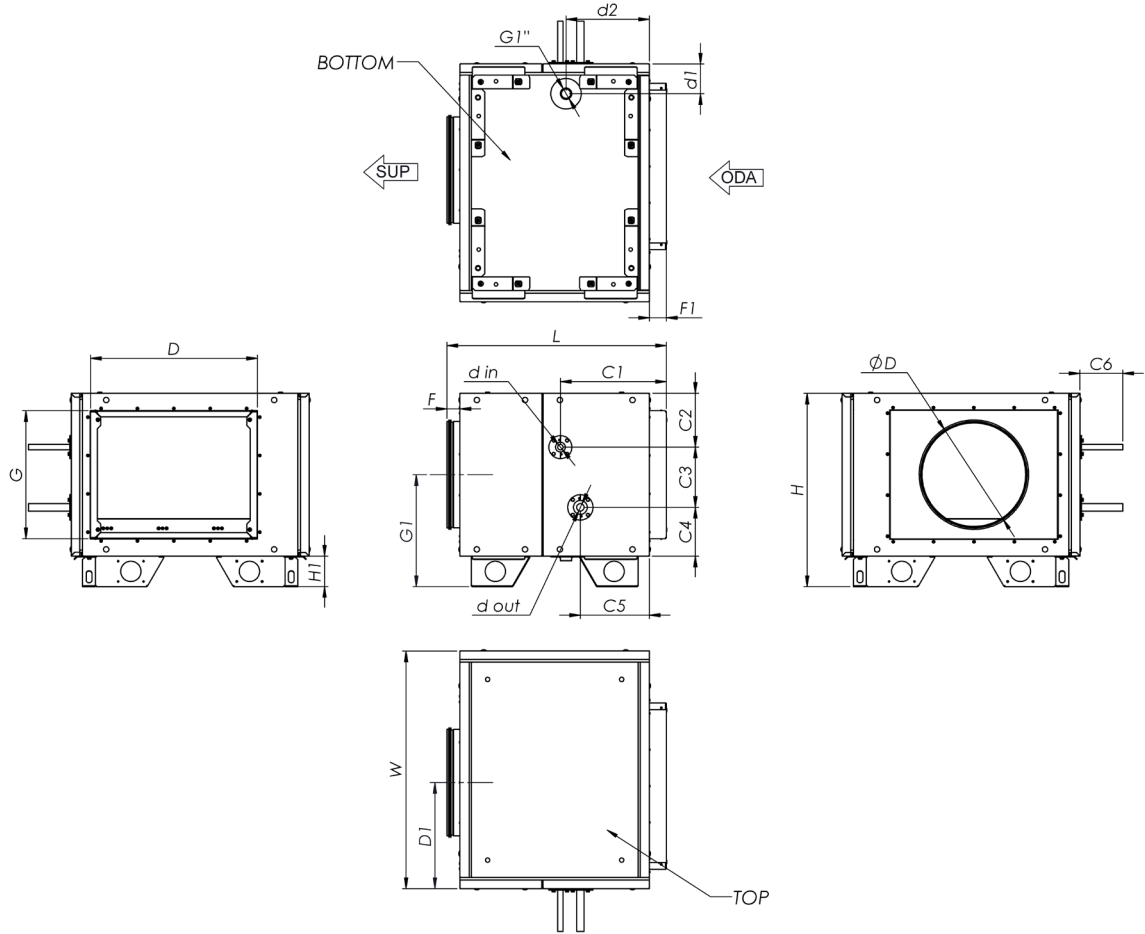

Fig. 8.1.31 Comfort box DX left for AmberAir Compact-S-R-1000-H / AmberAir Compact S-R-1500-H / AmberAir Compact S-R-2000-H dimensions

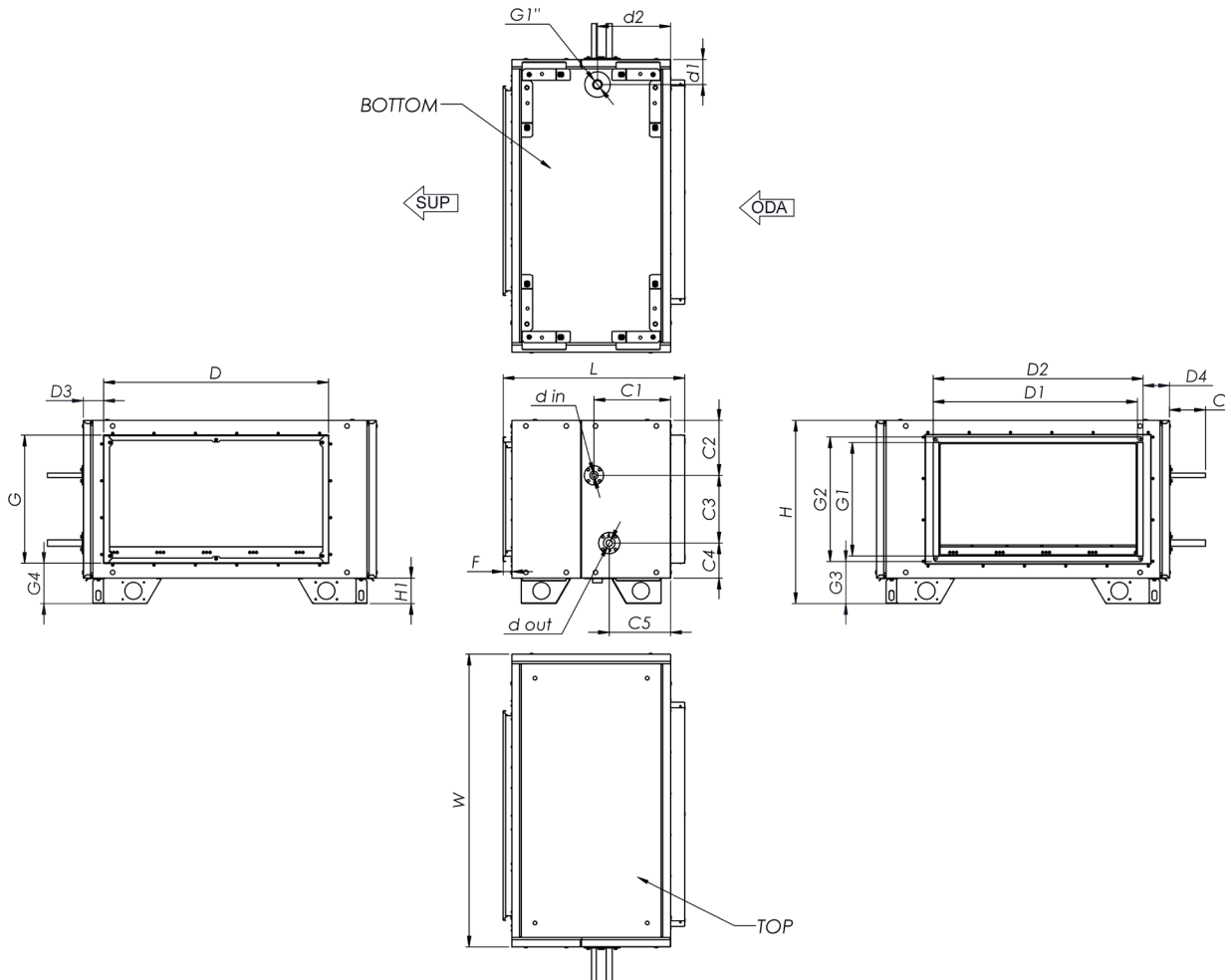
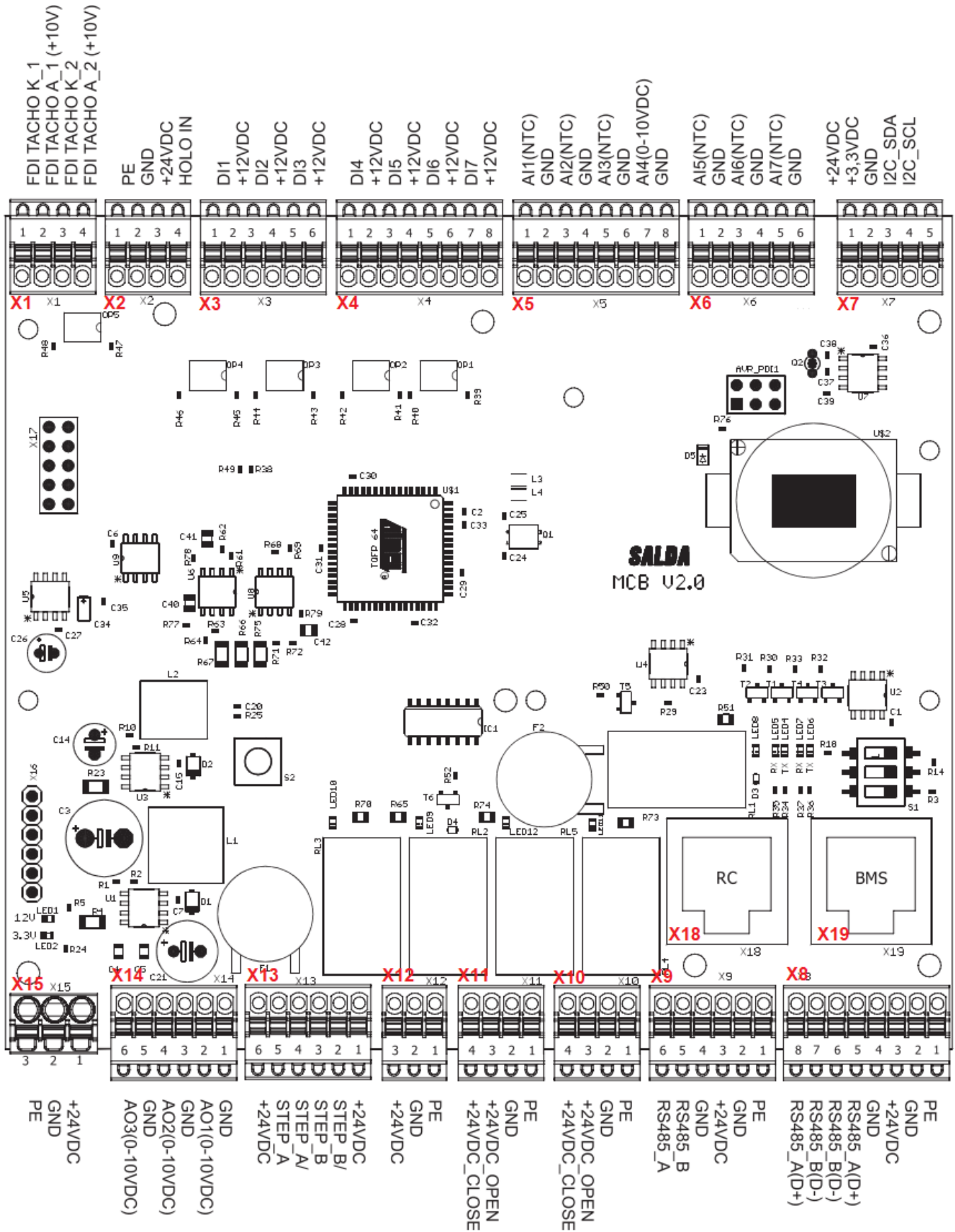

Fig. 8.1.32 Comfort box DX left for AmberAir Compact S-R-3000-H dimensions

Comfort box DX left for AmberAir Compact-S-R H		1000	1500	2000	3000
L	[mm]	650	655	680	640
W	[mm]	704	754	854	1 033
H	[mm]	572	600	650	
ØD	[mm]	315	355	400	-
D	[mm]	492	538	638	792
G	[mm]	378	402	452	
F	[mm]	39	43	68	30
F1	[mm]	50			
H1	[mm]	90			
C1	[mm]	313	265	320	270
C2	[mm]	159	174	192	194
C3	[mm]	178	201	243	239
C4	[mm]	144	132	121	124
C5	[mm]	204	194	216	
C6	[mm]	127			
D1	[mm]	314	339	389	700
D2	[mm]	-			
D3	[mm]	-			
D4	[mm]	-			
din	[mm]	12	16		
dout	[mm]	12	22		
G1	[mm]	331	343	368	400
G2	[mm]	-			
G3	[mm]	-			
G4	[mm]	-			
d1	[mm]	88			
d2	[mm]	246	252	258	
WEIGHT	[kg]	64	79	86	101
INSULATION THICKNESS	[mm]	50			

8.2. CONNECTION TO WIRING TERMINALS

MCB:



WIRING TERMINALS	TYPE	FUNCTION
X1: 1,3	Cathode	
X1: 2,4	Anode	
X2: 1,2,3,4	Holo input and power	
X3: 1	Digital input (NO/NC)	Electrical heater auto protection/combined heating cooling coil reverse
X3: 3	Digital input (NO/NC)	Electrical heater manual protection/water heater protection
X3: 5	Digital input (NO/NC)	Supply fan protection
X3: 2,4,6	Reference voltage	12VDC output for digital input ref.
X4: 1	Digital input (NO/NC)	Fire protection
X4: 3	Digital input (NO/NC)	
X4: 5	Digital input (NO/NC)	Rotor alarm
X4: 7	Digital input (NO/NC)	Exhaust fan protection
X4: 2,4,6,8	Reference voltage	12VDC output for digital input ref.
X5: 1	Analog input (NTC)	Supply air temp. sensor (SUP)
X5: 3	Analog input (NTC)	Outdoor air temp. sensor (ODA)
X5: 5	Analog input (NTC)	Exhaust air temp. sensor (EHA)
X5: 7	Analog input (0-10V)	
X5: 2,4,6,8	Ground	Common ground for analog input ref.
X6: 1	Analog input (NTC)	Extract air temp. sensor (ETA)
X6: 3	Analog input (NTC)	
X6: 5	Analog input (NTC)	Water heater temp. sensor (WTO)
X6: 2,4,6	Ground	Common ground for analog input ref.
X7: 1,2,3,4,5,	Communication interface and power	I2C and power supply for MCB EX2 module
X8: 1,2,3,4,5,6,7,8	Communication interface and power	RS485 and 24VDC power supply for BMS
X9: 1,2,3,4,5,6	Communication interface and power	RS485 and power supply for remote controller
X10: 1,2,3,4	24VDC digital outputs and ref.	
X11: 1,2,3,4	24VDC digital outputs and ref.	
X12: 1,2,3	Power	24VDC power supply for water heater actuator
X13: 1,2,3,4,5,6	Stepper output	
X14: 2	Analog output (0-10V)	Supply fan control
X14: 4	Analog output (0-10V)	Exhaust fan control
X14: 6	Analog output (0-10V)	Heater control
X14: 1,3,5	Ground	Common ground for analog output ref.
X15: 1,2,3	Power	MCB controller power supply
X18	Communication interface and power	RS485 and power supply for remote controller
X19	Communication interface and power	RS485 and 24VDC power supply for BMS

EX1 module:

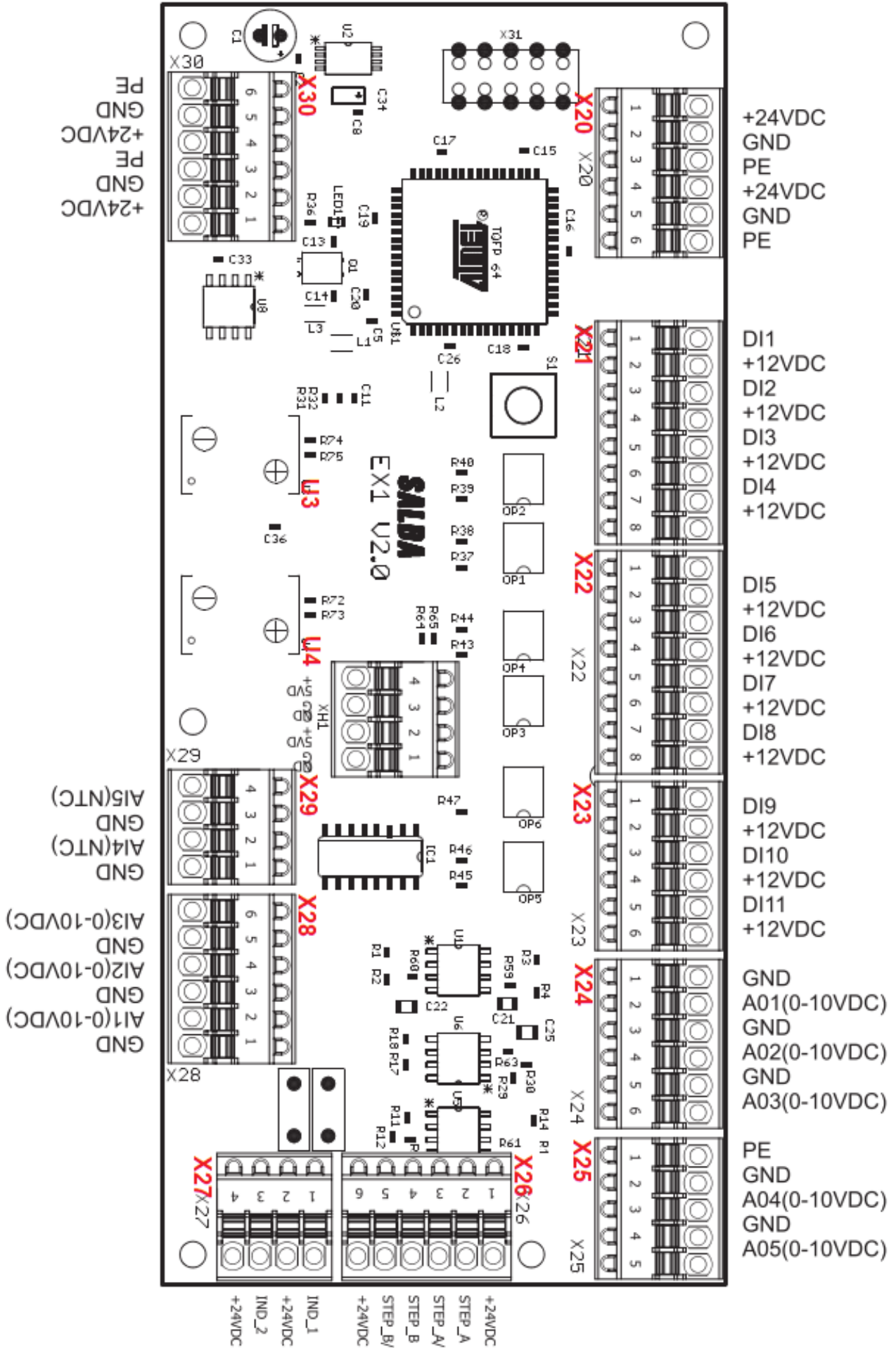

WIRING TERMINALS	TYPE	FUNCTION
X20: 1,2,3	Power	24VDC power supply for water preheater actuator
X20: 4,5,6	Power	24VDC power supply for water cooler actuator
X21: 1	Digital input (NO/NC)	Electrical preheater aut. protection
X21: 3	Digital input (NO/NC)	Electrical preheater man. protection
X21: 5	Digital input (NO/NC)	System mode switch
X21: 7	Digital input (NO/NC)	Fans speed switch
X21: 2,4,6,8	Reference voltage	12VDC output for digital input ref.
X22: 1	Digital input (NO/NC)	DX cooler protection
X22: 3	Digital input (NO/NC)	Supply air filter pressure switch
X22: 5	Digital input (NO/NC)	Extract air filter pressure switch
X22: 7	Digital input (NO/NC)	Fireplace protection
X22: 2,4,6,8	Reference voltage	12VDC output for digital input ref.
X23: 1	Digital input (NO/NC)	Fire damper opened
X23: 3	Digital input (NO/NC)	Fire damper closed
X23: 5	Digital input (NO/NC)	
X23: 2,4,6	Reference voltage	12VDC output for digital input ref.
X24: 2	Analog output (0-10V)	Preheater control
X24: 4	Analog output (0-10V)	DX cooler control
X24: 6	Analog output (0-10V)	Combined heating/cooling coil control
X24: 1,3,5	Ground	Common ground for analog output ref.
X25: 1,2,3	Analog output (0-10V) and ref.	
X25: 5	Analog output (0-10V)	Rotor speed control
X25: 4	Ground	Common ground for analog output ref.
X26: 1,2,3,4,5,6	Stepper output	
X27: 1	Digital ground output	Working indication
X27: 3	Digital ground output	Alarm indication
X27: 2,4	Reference voltage	24VDC (max 50mA, 1,2W) output for digital ground output ref.
X28: 2	Analog input (0-10V)	Air quality sensor transmitter 1
X28: 4	Analog input (0-10V)	Air quality sensor transmitter 2
X28: 6	Analog input (0-10V)	
X28: 1,3,5	Ground	Common ground for analog input ref.
X29: 2	Analog input (NTC)	Combined heating/cooling coil temp. sensor (WTO)
X29: 4	Analog input (NTC)	Water preheater temp. sensor (WTO)
X29: 1,3	Ground	Common ground for analog input ref.
X30: 1,2,3	Power	24VDC power supply for air quality sensor 1
X30: 4,5,6	Power	24VDC power supply for air quality sensor 2
XH1: 1,2,3,4,5,6	Power	
U3	Pressure sensor	Supply air pressure sensor
U4	Pressure sensor	Extract/Exhaust air pressure sensor

EX2 module:

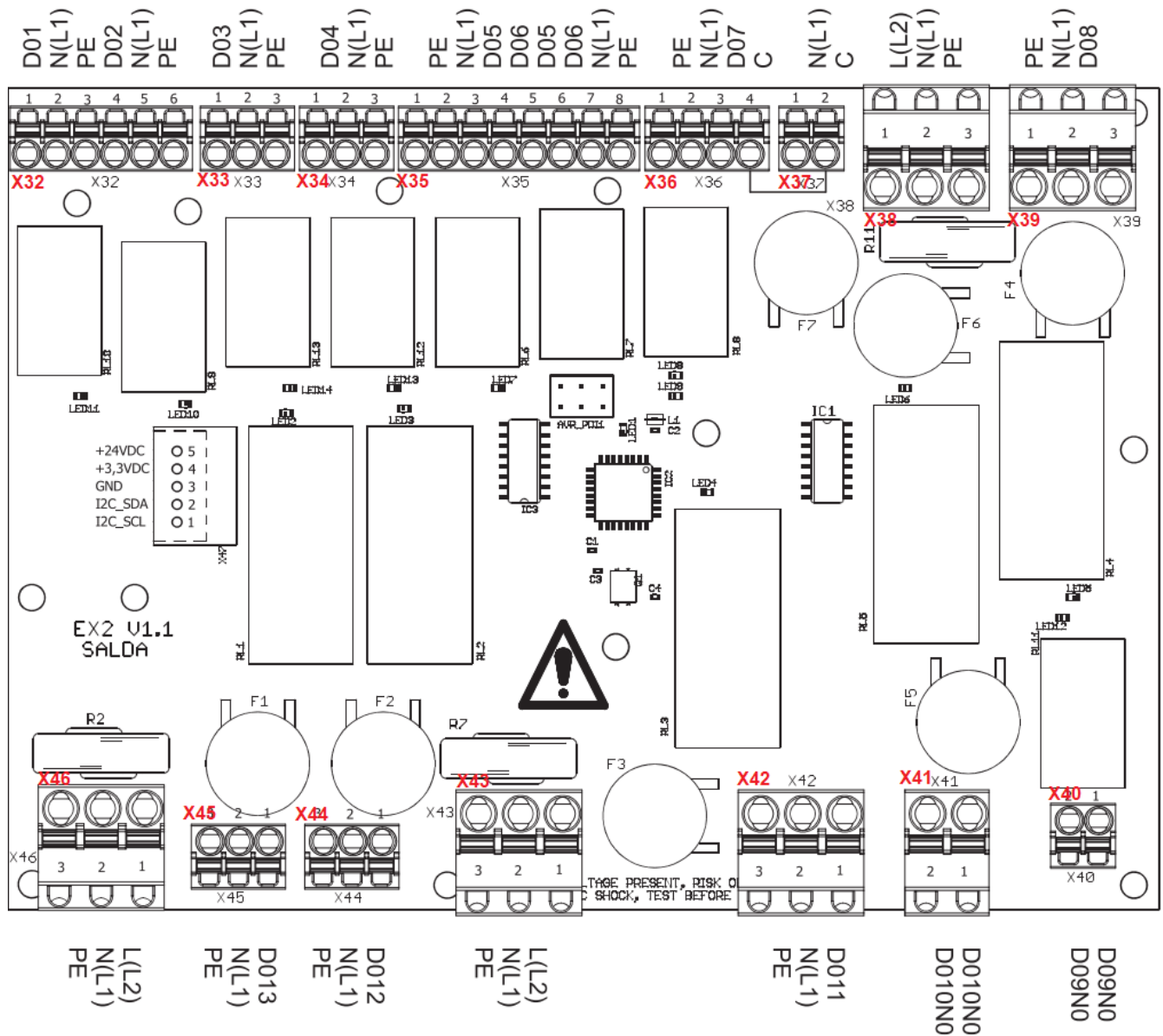

WIRING TERMINALS	TYPE	FUNCTION
X32: 1	230VAC digital output (max 100mA)	Fire damper actuator 1 open
X32: 4	230VAC digital output (max 100mA)	Fire damper actuator 2 open
X32: 2,5	Neutral	Neutral contact for digital output ref.
X32: 3,6	Earth	Earth contact for the damper actuators
X33: 1	230VAC digital output	Combined heating/cooling coil circulation pump start
X33: 2	Neutral	Neutral contact for digital output ref.
X33: 3	Earth	Earth contact for the circulation pump
X34: 1,2,3	230VAC digital outputs and ref.	
X35: 3,5	230VAC digital output	Outdoor/exhaust air dampers open
X35: 4,6	230VAC digital output	Outdoor/exhaust air dampers close
X35: 1,8	Earth	Earth contact for the damper actuators
X35: 2,7	Neutral	Neutral contact for digital output ref.
X36: 3	230VAC digital output	Rotor motor controller power
X36: 1	Earth	Earth contact for Rotor motor controller
X36: 2	Neutral	Neutral contact for digital output ref.
X36: 4	Capacitor	
X37: 1,2	Capacitor	
X38: 1,2,3	Power	230VAC power supply for X32-X36, X39
X39: 3	230VAC digital output	Electrical heater starts/water heater circulation pump starts

WIRING TERMINALS	TYPE	FUNCTION
X39: 1	Earth	Earth contact for the circulation pump
X39: 2	Neutral	Neutral contact for digital output ref.
X40: 1,2	Digital output	DX cooler reverse
X41: 1,2	Digital output	DX cooler start
X42: 1	230VAC digital output	Electrical preheater starts/water preheater circulation pump starts
X42: 2	Neutral	Neutral contact for digital output ref.
X42: 3	Earth	Earth contact for the circulation pump
X43: 1,2,3	Power	230VAC power supply for X42
X44: 1	230VAC digital output (max 3,5A)	Exhaust fan power
X44: 2	Neutral	Neutral contact for digital output ref.
X44: 3	Earth	Earth contact for fan
X45: 1	230VAC digital output (max 3,5A)	Supply fan power
X45: 2	Neutral	Neutral contact for digital output ref.
X45: 3	Earth	Earth contact for fan
X46: 1,2,3	Power	230VAC power supply for X44-X45
X47: 1,2,3,4,5,	Communication interface and power	I2C and power supply for MCB EX2 module

8.3. ELECTRICAL DATA



Max. power and current values are provided only for units with factory-integrated components. When additional accessories are connected to the unit, total power and current may increase.

AMBERAIR COMPACT S-R/RS-1000		H-C1	H-E-C1	H-E2-C1	H-CO-C1	H-DX-C1
EXHAUST FAN						
Phases/Voltage	[50 Hz/VAC]	1N~/230	1N~/ 230	1N~/ 230	1N~/ 230	1N~/ 230
Max. power consumption	[kW]	0,5	0,5	0,5	0,5	0,5
Max. current	[A]	2,2	2,2	2,2	2,2	2,2
RPM	[RPM]	3740	3740	3740	3740	3740
Control signal	[VDC]	0-10	0-10	0-10	0-10	0-10
IP class		IP55	IP55	IP55	IP55	IP55
SUPPLY FAN						
Phases/Voltage	[50 Hz/VAC]	1N~/230	1N~/ 230	1N~/ 230	1N~/ 230	1N~/ 230
Max. power consumption	[kW]	0,5	0,5	0,5	0,5	0,5
Max. current	[A]	2,2	2,2	2,2	2,2	2,2
RPM	[RPM]	3740	3740	3740	3740	3740
Control signal	[VDC]	0-10	0-10	0-10	0-10	0-10
IP class		IP55	IP55	IP55	IP55	IP55
AHU Power supply Phases/Voltage	[50 Hz/VAC]	1N~/230	3N~/400	3N~/ 400	1N~/230	1N~/230
Integrated electrical heater max. power consumption	[kW]	-	3,0	4,5	-	-
Max. power consumption (Rated power)	[kW]	1,15	4,15	5,65	1,15	1,15
Max. current (Rated current)	[A]	5,04	9,39	11,54	5,04	5,04
Recommended fuse (recommended short circuit breaker)	[A]	10	16	16	10	10
Controller		MCB	MCB	MCB	MCB	MCB
Casing IP class		IP-34	IP-34	IP-34	IP-34	IP-34

AmberAir Compact S-R-1500-H-E-R-C1 AlZn

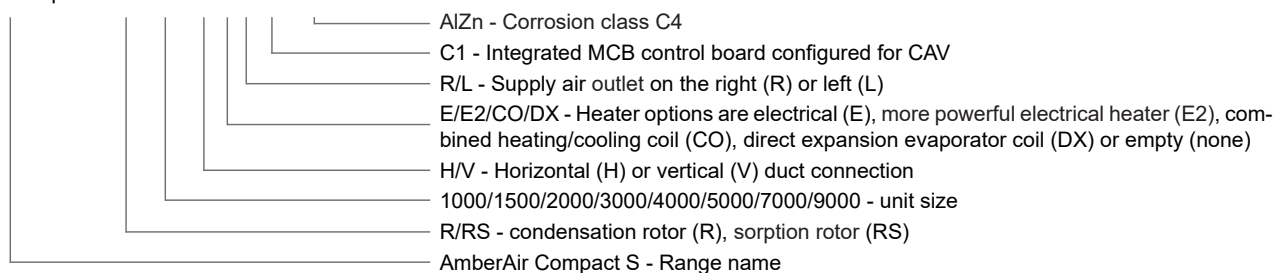

AMBERAIR COMPACT S-R/RS-1500		H-C1	H-E-C1	H-E2-C1	H-CO-C1	H-DX-C1
EXHAUST FAN						
Phases/Voltage	[50 Hz/VAC]	1N~/ 230	1N~/ 230	1N~/ 230	1N~/ 230	1N~/ 230
Max. power consumption	[kW]	0,5	0,5	0,5	0,5	0,5
Max. current	[A]	2,2	2,2	2,2	2,2	2,2
RPM	[RPM]	2700	2700	2700	2700	2700
Control signal	[VDC]	0-10	0-10	0-10	0-10	0-10
IP class		IP55	IP55	IP55	IP55	IP55
SUPPLY FAN						
Phases/Voltage	[50 Hz/VAC]	1N~/ 230	1N~/ 230	1N~/ 230	1N~/ 230	1N~/ 230
Max. power consumption	[kW]	0,5	0,5	0,5	0,5	0,5
Max. current	[A]	2,2	2,2	2,2	2,2	2,2
RPM	[RPM]	2700	2700	2700	2700	2700
Control signal	[VDC]	0-10	0-10	0-10	0-10	0-10
IP class		IP55	IP55	IP55	IP55	IP55
AHU Power supply Phases/Voltage	[50 Hz/VAC]	1N~/230	3N~/400	3N~/400	1N~/230	1N~/230
Integrated electrical heater max. power consumption	[kW]	-	3,6	6,6	-	-
Max. power consumption (Rated power)	[kW]	1,15	4,75	7,75	1,15	1,15
Max. current (Rated current)	[A]	5,04	10,24	14,60	5,04	5,04
Recommended fuse (recommended short circuit breaker)	[A]	10	16	25	10	10
Controller		MCB	MCB	MCB	MCB	MCB
Casing IP class		IP-34	IP-34	IP-34	IP-34	IP-34

AMBERAIR COMPACT S-R/RS-2000		H-C1	H-E-C1	H-E2-C1	H-CO- C1	H-DX-C1
EXHAUST FAN						
Phases/Voltage	[50 Hz/VAC]	1N~/ 230	1N~/ 230	1N~/ 230	1N~/ 230	1N~/ 230
Max. power consumption	[kW]	0,72	0,72	0,72	0,72	0,72
Max. current	[A]	3,1	3,1	3,1	3,1	3,1
RPM	[RPM]	2800	2800	2800	2800	2800
Control signal	[VDC]	0-10	0-10	0-10	0-10	0-10
IP class		IP54	IP54	IP54	IP54	IP54
SUPPLY FAN						
Phases/Voltage	[50 Hz/VAC]	1N~/ 230	1N~/ 230	1N~/ 230	1N~/ 230	1N~/ 230
Max. power consumption	[kW]	0,72	0,72	0,72	0,72	0,72
Max. current	[A]	3,1	3,1	3,1	3,1	3,1
RPM	[RPM]	2800	2800	2800	2800	2800
Control signal	[VDC]	0-10	0-10	0-10	0-10	0-10
IP class		IP54	IP54	IP54	IP54	IP54
AHU Power supply Phases/Voltage	[50 Hz/VAC]	1N~/230	3N~/400	3N~/400	1N~/230	1N~/230
Integrated electrical heater max. power consumption	[kW]	-	4,8	9,0	-	-
Max. power consumption (Rated power)	[kW]	1,58	6,38	10,58	1,58	1,58
Max. current (Rated current)	[A]	6,84	10,68	16,74	6,84	6,84
Recommended fuse (recommended short circuit breaker)	[A]	10	16	25	10	10
Controller		MCB	MCB	MCB	MCB	MCB
Casing IP class		IP-34	IP-34	IP-34	IP-34	IP-34

AMBERAIR COMPACT S-R/RS-3000		H-C1	H-E-C1	H-E2-C1	H-CO-C1	H-DX-C1
EXHAUST FAN						
Phases/Voltage	[50 Hz/VAC]	1N~/ 230	1N~/ 230	1N~/ 230	1N~/ 230	1N~/ 230
Max. power consumption	[kW]	1,5	1,5	1,5	1,5	1,5
Max. current	[A]	6,5	6,5	6,5	6,5	6,5
RPM	[RPM]	3200	3200	3200	3200	3200
Control signal	[VDC]	0-10	0-10	0-10	0-10	0-10
IP class		IP54	IP54	IP54	IP54	IP54
SUPPLY FAN						
Phases/Voltage	[50 Hz/VAC]	1N~/ 230	1N~/ 230	1N~/ 230	1N~/ 230	1N~/ 230
Max. power consumption	[kW]	1,5	1,5	1,5	1,5	1,5
Max. current	[A]	6,5	6,5	6,5	6,5	6,5
RPM	[RPM]	3200	3200	3200	3200	3200
Control signal	[VDC]	0-10	0-10	0-10	0-10	0-10
IP class		IP54	IP54	IP54	IP54	IP54
AHU Power supply Phases/Voltage	[50 Hz/VAC]	1N~/230	3N~/400	3N~/400	1N~/230	1N~/230
Integrated electrical heater max. power consumption	[kW]	-	7,2	12,0	-	-
Max. power consumption (Rated power)	[kW]	3,15	10,35	15,15	3,15	3,15
Max. current (Rated current)	[A]	13,64	17,54	24,48	13,64	13,64
Recommended fuse (recommended short circuit breaker)	[A]	20	25	40	20	20
Controller		MCB	MCB	MCB	MCB	MCB
Casing IP class		IP-34	IP-34	IP-34	IP-34	IP-34

AMBERAIR COMPACT S-R/RS-4000		H-C1	H-E-C1	H-E2-C1	H-CO-C1	H-DX-C1
EXHAUST FAN						
Phases/Voltage	[50 Hz/VAC]	3N~/400	3N~/400	3N~/400	3N~/400	3N~/400
Max. power consumption	[kW]	1,8	1,8	1,8	1,8	1,8
Max. current	[A]	2,8	2,8	2,8	2,8	2,8
RPM	[RPM]	3410	3410	3410	3410	3410
Control signal	[VDC]	0-10	0-10	0-10	0-10	0-10
IP class		IP54	IP54	IP54	IP54	IP54
SUPPLY FAN						
Phases/Voltage	[50 Hz/VAC]	3N~/400	3N~/400	3N~/400	3N~/400	3N~/400
Max. power consumption	[kW]	1,8	1,8	1,8	1,8	1,8
Max. current	[A]	2,8	2,8	2,8	2,8	2,8
RPM	[RPM]	3410	3410	3410	3410	3410
Control signal	[VDC]	0-10	0-10	0-10	0-10	0-10
IP class		IP54	IP54	IP54	IP54	IP54
AHU Power supply Phases/Voltage	[50 Hz/VAC]	3N~/400	3N~/400	3N~/400	3N~/400	3N~/400
Integrated electrical heater max. power consumption	[kW]	-	12,0	180	-	-
Max. power consumption (Rated power)	[kW]	3,75	15,75	21,75	3,75	3,75
Max. current (Rated current)	[A]	6,24	23,58	32,24	6,24	6,24
Recommended fuse (recommended short circuit breaker)	[A]	10	32	40	10	10
Controller		MCB	MCB	MCB	MCB	MCB
Casing IP class		IP-34	IP-34	IP-34	IP-34	IP-34

AmberAir Compact S-R-1500-H-E-R-C1 AlZn

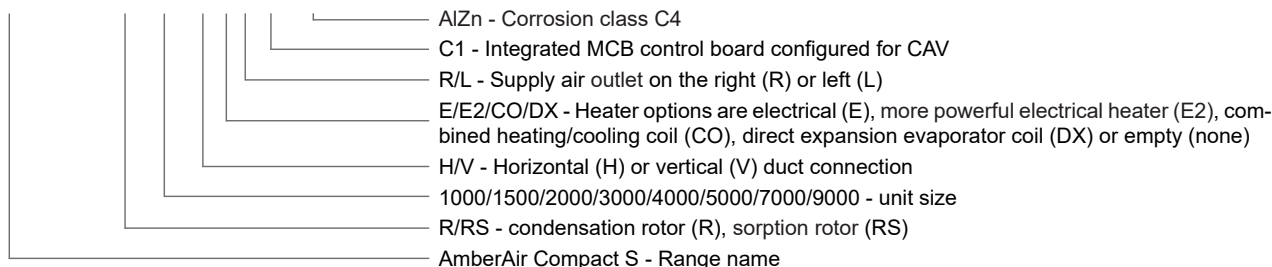

AMBERAIR COMPACT S-R/RS-5000		H-C1	H-E-C1	H-E2-C1	H-CO-C1	H-DX-C1
EXHAUST FAN						
Phases/Voltage	[50 Hz/VAC]	3N~/400	3N~/400	3N~/400	3N~/400	3N~/400
Max. power consumption	[kW]	1,95	1,95	1,95	1,95	1,95
Max. current	[A]	3,3	3,3	3,3	3,3	3,3
RPM	[RPM]	2300	2300	2300	2300	2300
Control signal	[VDC]	0-10	0-10	0-10	0-10	0-10
IP class		IP55	IP55	IP55	IP55	IP55
SUPPLY FAN						
Phases/Voltage	[50 Hz/VAC]	3N~/400	3N~/400	3N~/400	3N~/400	3N~/400
Max. power consumption	[kW]	1,95	1,95	1,95	1,95	1,95
Max. current	[A]	3,3	3,3	3,3	3,3	3,3
RPM	[RPM]	2300	2300	2300	2300	2300
Control signal	[VDC]	0-10	0-10	0-10	0-10	0-10
IP class		IP55	IP55	IP55	IP55	IP55
AHU Power supply Phases/Voltage	[50 Hz/VAC]	3N~/400	3N~/400	3N~/400	3N~/400	3N~/400
Integrated electrical heater max. power consumption	[kW]	-	12,0	21,0	-	-
Max. power consumption (Rated power)	[kW]	4,05	16,05	25,05	4,05	4,05
Max. current (Rated current)	[A]	7,24	23,58	37,60	7,24	7,24
Recommended fuse (recommended short circuit breaker)	[A]	10	32	63	10	10
Controller		MCB	MCB	MCB	MCB	MCB
Casing IP class		IP-34	IP-34	IP-34	IP-34	IP-34

AMBERAIR COMPACT S-R/RS-7000		H-C1	H-E-C1	H-E2-C1	H-CO-C1	H-DX-C1
EXHAUST FAN						
Phases/Voltage	[50 Hz/VAC]	3N~/400	3N~/400	3N~/400	3N~/400	3N~/400
Max. power consumption	[kW]	3,5	3,5	3,5	3,5	3,5
Max. current	[A]	5,6	5,6	5,6	5,6	5,6
RPM	[RPM]	1950	1950	1950	1950	1950
Control signal	[VDC]	0-10	0-10	0-10	0-10	0-10
IP class		IP55	IP55	IP55	IP55	IP55
SUPPLY FAN						
Phases/Voltage	[50 Hz/VAC]	3N~/400	3N~/400	3N~/400	3N~/400	3N~/400
Max. power consumption	[kW]	3,5	3,5	3,5	3,5	3,5
Max. current	[A]	5,6	5,6	5,6	5,6	5,6
RPM	[RPM]	1950	1950	1950	1950	1950
Control signal	[VDC]	0-10	0-10	0-10	0-10	0-10
IP class		IP55	IP55	IP55	IP55	IP55
AHU Power supply Phases/Voltage	[50 Hz/VAC]	3N~/400	3N~/400	3N~/400	3N~/400	3N~/400
Integrated electrical heater max. power consumption	[kW]	-	18,0	30,0	-	-
Max. power consumption (Rated power)	[kW]	7,15	25,15	37,15	7,15	7,15
Max. current (Rated current)	[A]	11,84	37,85	55,20	11,84	11,84
Recommended fuse (recommended short circuit breaker)	[A]	16	63	63	16	16
Controller		MCB	MCB	MCB	MCB	MCB
Casing IP class		IP-34	IP-34	IP-34	IP-34	IP-34

AMBERAIR COMPACT S-R/RS-9000		H-C1	H-E-C1	H-E2-C1	H-CO-C1	H-DX-C1
EXHAUST FAN						
Phases/Voltage	[50 Hz/VAC]	3N~/400	3N~/400	3N~/400	3N~/400	3N~/400
Max. power consumption	[kW]	4,15	4,15	4,15	4,15	4,15
Max. current	[A]	6,3	6,3	6,3	6,3	6,3
RPM	[RPM]	2480	2480	2480	2480	2480
Control signal	[VDC]	0-10	0-10	0-10	0-10	0-10
IP class		IP55	IP55	IP55	IP55	IP55
SUPPLY FAN						
Phases/Voltage	[50 Hz/VAC]	3N~/400	3N~/400	3N~/400	3N~/400	3N~/400
Max. power consumption	[kW]	4,15	4,15	4,15	3,5	3,5
Max. current	[A]	6,3	6,3	6,3	5,6	5,6
RPM	[RPM]	2480	2480	2480	1950	1950
Control signal	[VDC]	0-10	0-10	0-10	0-10	0-10
IP class		IP55	IP55	IP55	IP55	IP55
AHU Power supply Phases/Voltage	[50 Hz/VAC]	3N~/400	3N~/400	3N~/400	3N~/400	3N~/400
Integrated electrical heater max. power consumption	[kW]	-	21,0	45,0	-	-
Max. power consumption (Rated power)	[kW]	8,45	29,45	53,4	8,45	8,45
Max. current (Rated current)	[A]	13,24	43,58	78,2	13,24	13,24
Recommended fuse (recommended short circuit breaker)	[A]	20	63	100	20	20
Controller		MCB	MCB	MCB	MCB	MCB
Casing IP class		IP-34	IP-34	IP-34	IP-34	IP-34

AmberAir Compact S-R-1500-H-E-R-C1 AlZn

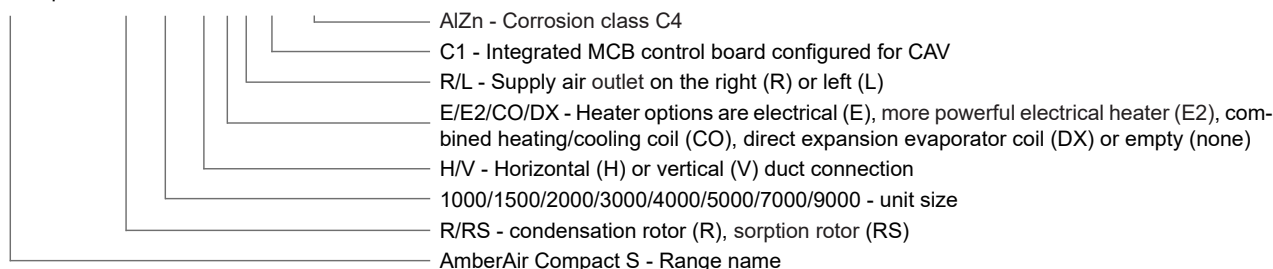

8.4. FILTER DATA

	SUPPLY AIR FILTER			[PCS.]	EXHAUST AIR FILTER			[PCS.]
AmberAir Compact S-R/RS-1000-H	Pocket 695x375x350/10	ePM1 55%		1	Pocket 695x495x245/8	ePM10 65%		1
AmberAir Compact S-R/RS-1500-H	Pocket 745x400x350/12	ePM1 55%		1	Pocket 745x520x240/10	ePM10 65%		1
AmberAir Compact S-R/RS-2000-H	Pocket 845x450x350/13	ePM1 55%		1	Pocket 845x570x240/11	ePM10 65%		1
AmberAir Compact S-R/RS-3000-H	Pocket 512x505x350/7	ePM1 55%		2	Pocket 512x625x240/7	ePM10 65%		2
AmberAir Compact S-R/RS-4000-H	Pocket 587x575x450/8	ePM1 55%		1	Pocket 587x695x300/7	ePM10 65%		1
AmberAir Compact S-R/RS-5000-H	Pocket 632x620x410/10	ePM1 55%		2	Pocket 632x740x350/8	ePM10 65%		2
AmberAir Compact S-R/RS-7000-H	Pocket 750x743x450/11	ePM1 55%		2	Pocket 871x743x300/10	ePM10 65%		2
AmberAir Compact S-R/RS-9000-H	Pocket 553x829x450/8	ePM1 55%		3	Pocket 553x902x400/8	ePM10 65%		3

8.5. SAFETY DATA

	AMBERAIR COMPACT S-R	AMBERAIR COMPACT S-RS
Outdoor air temp. without frost protection	-23 .. 40 °C	-23 .. 40 °C
Ambient air temp.	-23 .. 40 °C	-23 .. 40 °C
Min. extracted air temp	15 °C	15 °C
Max. extracted air humidity	60 %	60 %
Max. ambient air humidity	80 %	80 %

8.6. PIPING AND INSTRUMENTATION DIAGRAM

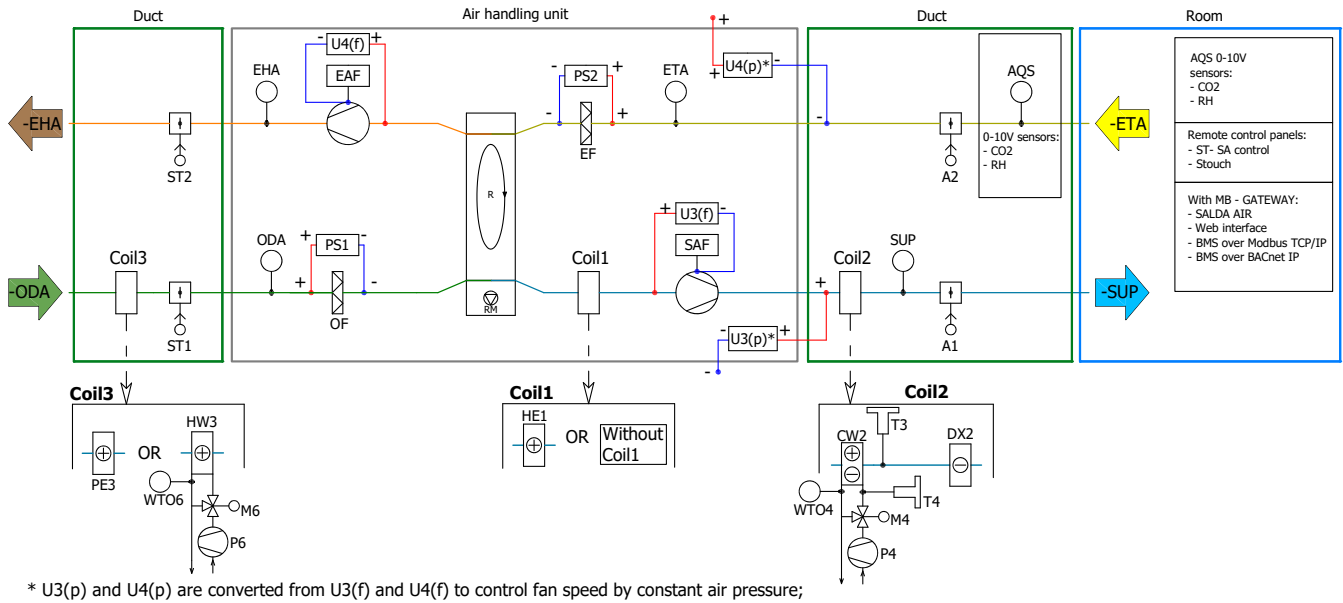

Fig. 8.6.1 Horizontal right units with integrated electrical heater or without integrated heater/cooler

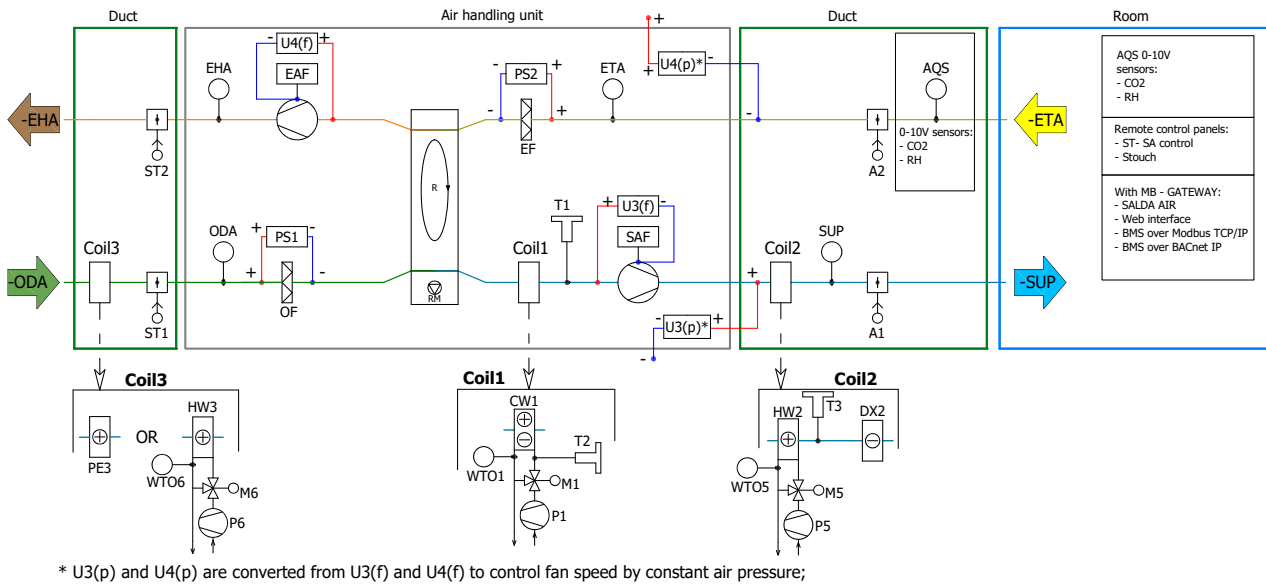

Fig. 8.6.2 Horizontal right units with integrated combined heating/cooling coil

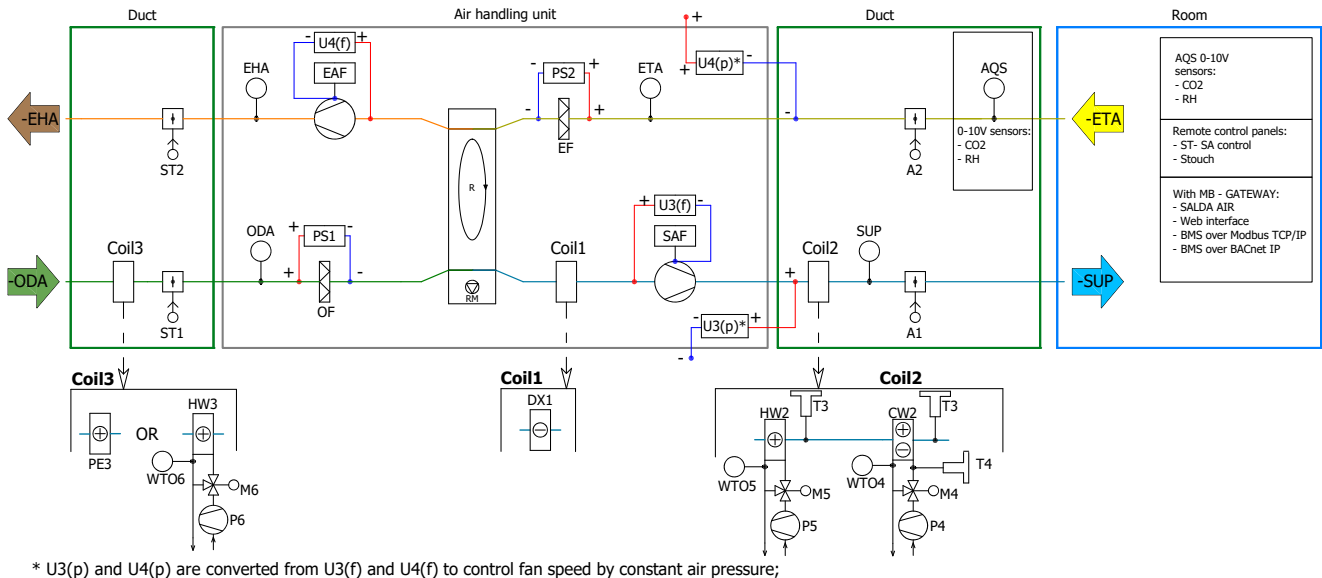

Fig. 8.6.3 Horizontal right units with integrated DX cooling coil

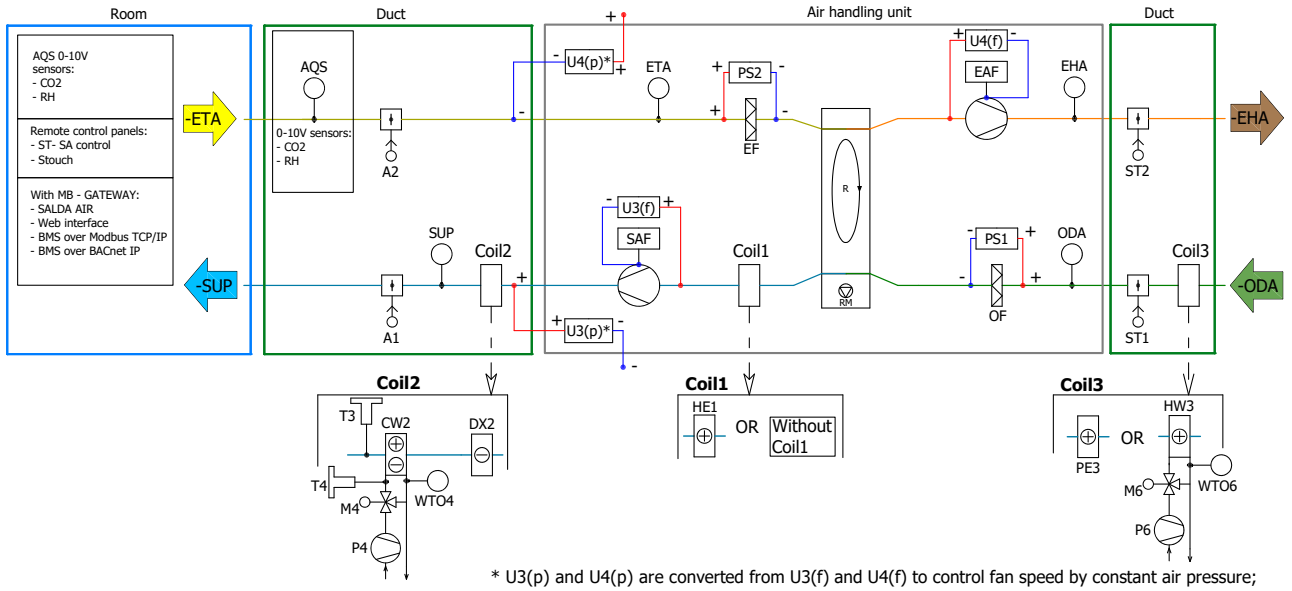

Fig. 8.6.4 Horizontal left units with integrated electrical heater or without integrated heater/cooler

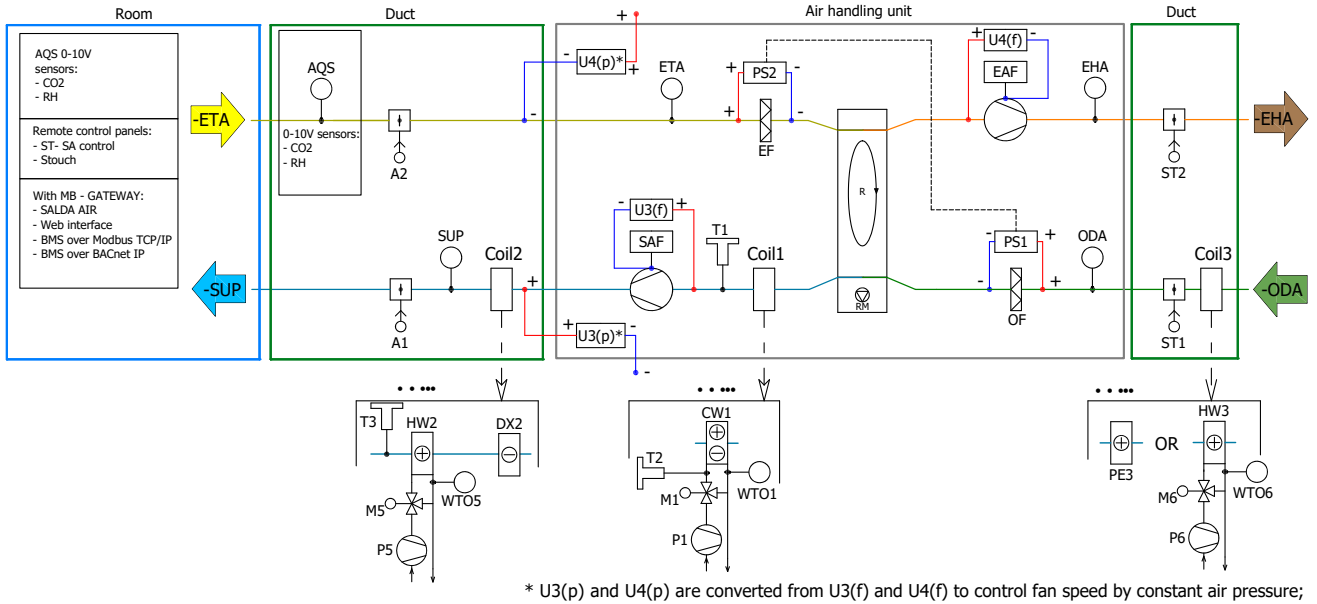

Fig. 8.6.5 Horizontal left units with integrated combined heating/cooling coil

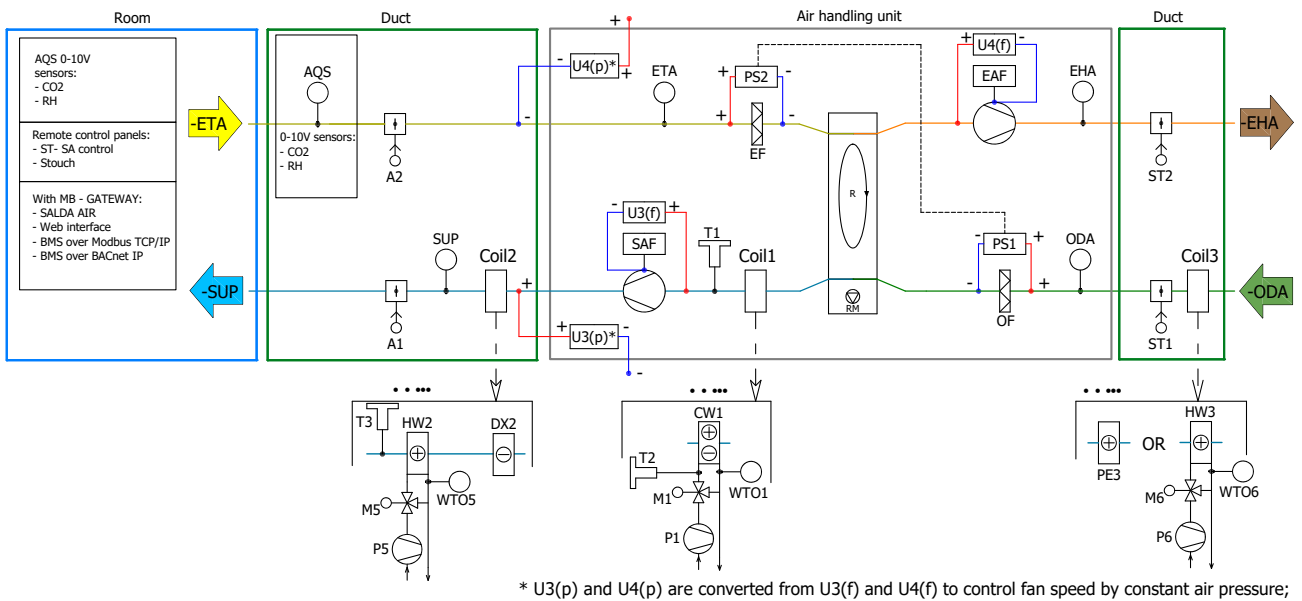

Fig. 8.6.6 Horizontal left units with integrated DX cooling coil

List of integrated components		Availability	List of optional accessories		Availability
SAF	Air fan supply	+	CW2	Heating/cooling coil combined	Two for single Air Handling unit (depends on version)
EAF	Air fan exhaust	+	HW2	Heater water	
OF	Air filter outdoor	+	DX2	Cooler DX	One for single Air Handling unit
EF	Air filter extract	+	PE3	Preheater electrical	
PS1	Differential pressure switch for OF	+	HW3	Preheater water	Only with CW1
PS2	Differential pressure switch for EF	+	P1	Pump CW1 water circulation	
HE1	Heater electrical	One for single Air Handling unit (depends on version)	M1	Actuator CW1 water valve	Only with CW2 (when HE1/ HW2 is not used) or HW2
CW1	Heating/cooling coil combined		T2	Thermostat CW1 reverse	
DX1	Cooler DX		T3	Thermostat CW2/HW2 protection	
Without Coil1	no heater or cooler (empty)		WTO4	Temperature sensor CW2 return water	
WTO1	Temperature sensor CW1 return water	Only with CW1	P4	Pump CW2 water circulation	Only with CW2
T1	Thermostat CW1 protection	Only with CW1 (when HW2 is not used)	M4	Actuator CW2 water valve	
R	Heat exchanger rotor	+	T4	Thermostat CW2 reverse	
RM	Motor heat exchanger	+	WTO5	Temperature sensor HW2 return water	Only with HW2
SUP	Air temperature sensor supply	+	P5	Pump HW2 water circulation	
ODA	Air temperature sensor outdoor	+	M5	Actuator HW2 water valve	Only with HW3
EHA	Air temperature sensor exhaust	+	WTO6	Temperature sensor HW3 return water	
ETA	Air temperature sensor extract	+	P6	Pump HW3 water circulation	
U3(f)	Pressure sensor for constant SUP flow control	+	M6	Actuator HW3 water valve	
U4(f)	Pressure sensor for constant EHA flow control	+	ST1	Air damper outdoor	+
			ST2	Air damper exhaust	+
			A1	Fire dampers supply air	+
			A2	Fire dampers extract air	+
			AQS	Sensor air quality 0-10V duct/room	2
				Remote control panel	1
				MB-Gateway interfaces	+
			U3(p)*	Pressure sensor for constant SUP pressure control	Converts from U3(f),U4(f)
			U4(p)*	Pressure sensor for constant ETA pressure control	

* U3(p) and U4(p) are converted from U3(f) and U4(f) to control fan speed by constant air pressure

9. APPENDICES

9.1. ECODESIGN DATA

PRODUCT NAME	AMBERAIR COMPACT S-R-1000				AMBERAIR COMPACT S-RS-1000			
	H-C1	H-E/E2-C1	H-CO-C1	H-DX-C1	H-C1	H-E/E2-C1	H-CO-C1	H-DX-C1
Topology	Bidirectional				Bidirectional			
Type of HRS	Regenerative				Regenerative			
Type of drive	Variable speed				Variable speed			
Thermal efficiency	[%]	81			82			
Nominal NRVU flow rate	[m³/s]	0,28			0,28			
Effective electric power input	[kW]	0,462	0,470		0,462	0,470		
SFPint	[W/(m³/s)]	532	529	522	524	556	553	546
Maximum internal SFP	[W/(m³/s)]	1310			1324			
Face velocity	[m/s]	1,1			1,1			
Normal external pressure	[Pa]	250			250			
Internal pressure drop of ventilation components	[Pa]	140/96			148/104			
Static efficiency of fans used in accordance with Regulation (EU) No 327/2011	[%]	45/44		46/44	46/45		47/45	
Declared maximum internal leakage rates	[%]	3			3			
Declared maximum external leakage rates (CAL(R) @ +400 Pa)	[%]	1			1			
Declared maximum external leakage rates (CAL(R) @ -400 Pa)	[%]	1			1			
Filter class		C			C			
Visual filter warning		Pressure device			Pressure device			
Casing sound power level	[dB(A)]	49			49			
ERP compliance		2018			2018			
Internet address	https://select.salda.it							

PRODUCT NAME	AMBERAIR COMPACT S-R-1500				AMBERAIR COMPACT S-RS-1500			
	H-C1	H-E/E2-C1	H-CO-C1	H-DX-C1	H-C1	H-E/E2-C1	H-CO-C1	H-DX-C1
Topology	Bidirectional				Bidirectional			
Type of HRS	Regenerative				Regenerative			
Type of drive	Variable speed				Variable speed			
Thermal efficiency	[%]	81			82			
Nominal NRVU flow rate	[m³/s]	0,42			0,42			
Effective electric power input	[kW]	0,671	0,703		0,671	0,703		
SFPint	[W/(m³/s)]	723	720	721	721	753	751	752
Maximum internal SFP	[W/(m³/s)]	1283			1299			
Face velocity	[m/s]	1,4			1,4			
Normal external pressure	[Pa]	250			250			
Internal pressure drop of ventilation components	[Pa]	235/173			252/188			
Static efficiency of fans used in accordance with Regulation (EU) No 327/2011	[%]	58/55			60/57			
Declared maximum internal leakage rates	[%]	3			3			
Declared maximum external leakage rates (CAL(R) @ +400 Pa)	[%]	1			1			
Declared maximum external leakage rates (CAL(R) @ -400 Pa)	[%]	1			1			
Filter class		C			C			
Visual filter warning		Pressure device			Pressure device			
Casing sound power level	[dB(A)]	51			51			
ERP compliance		2018			2018			
Internet address	https://select.salda.it							

PRODUCT NAME	AMBERAIR COMPACT S-R-2000				AMBERAIR COMPACT S-RS-2000				
	H-C1	H-E/E2-C1	H-CO-C1	H-DX-C1	H-C1	H-E/E2-C1	H-CO-C1	H-DX-C1	
Topology	Bidirectional				Bidirectional				
Type of HRS	Regenerative				Regenerative				
Type of drive	Variable speed				Variable speed				
Thermal efficiency	[%]	81			82				
Nominal NRVU flow rate	[m³/s]	0,56			0,56				
Effective electric power input	[kW]	0,954		0,996		0,954		0,996	
SFPint	[W/(m³/s)]	791	789	789	789	822	820	821	821
Maximum internal SFP	[W/(m³/s)]	1257			1273				
Face velocity	[m/s]	1,5			1,5				
Normal external pressure	[Pa]	250			250				
Internal pressure drop of ventilation components	[Pa]	243/183			259/199				
Static efficiency of fans used in accordance with Regulation (EU) No 327/2011	[%]	53/55			55/57				
Declared maximum internal leakage rates	[%]	3			3				
Declared maximum external leakage rates (CAL(R) @ +400 Pa)	[%]	1			1				
Declared maximum external leakage rates (CAL(R) @ -400 Pa)	[%]	1			1				
Filter class		C			C				
Visual filter warning		Pressure device			Pressure device				
Casing sound power level	[dB(A)]	58			58				
ERP compliance		2018			2018				
Internet address	https://select.salda.it								

PRODUCT NAME	AMBERAIR COMPACT S-R-3000				AMBERAIR COMPACT S-RS-3000				
	H-C1	H-E/E2-C1	H-CO-C1	H-DX-C1	H-C1	H-E/E2-C1	H-CO-C1	H-DX-C1	
Topology	Bidirectional				Bidirectional				
Type of HRS	Regenerative				Regenerative				
Type of drive	Variable speed				Variable speed				
Thermal efficiency	[%]	80			81				
Nominal NRVU flow rate	[m³/s]	0,83			0,83				
Effective electric power input	[kW]	1,46		1,52		1,46		1,52	
SFPint	[W/(m³/s)]	848	846	843	842	848	846	843	842
Maximum internal SFP	[W/(m³/s)]	1187			1205				
Face velocity	[m/s]	1,6			1,6				
Normal external pressure	[Pa]	250			250				
Internal pressure drop of ventilation components	[Pa]	276/192			276/192				
Static efficiency of fans used in accordance with Regulation (EU) No 327/2011	[%]	56/54		57/54		56/54		57/54	
Declared maximum internal leakage rates	[%]	3			3				
Declared maximum external leakage rates (CAL(R) @ +400 Pa)	[%]	1			1				
Declared maximum external leakage rates (CAL(R) @ -400 Pa)	[%]	1			1				
Filter class		C			C				
Visual filter warning		Pressure device			Pressure device				
Casing sound power level	[dB(A)]	61			61				
ERP compliance		2018			2018				
Internet address	https://select.salda.it								

PRODUCT NAME	AMBERAIR COMPACT S-R-4000				AMBERAIR COMPACT S-RS-4000			
	H-C1	H-E/E2-C1	H-CO-C1	H-DX-C1	H-C1	H-E/E2-C1	H-CO-C1	H-DX-C1
Topology	Bidirectional				Bidirectional			
Type of HRS	Regenerative				Regenerative			
Type of drive	Variable speed				Variable speed			
Thermal efficiency	[%]	80			81			
Nominal NRVU flow rate	[m³/s]	1,11			1,11			
Effective electric power input	[kW]	2,01			2,01			
SFPint	[W/(m³/s)]	851	846	839	839	851	846	839
Maximum internal SFP	[W/(m³/s)]	1149			1166			
Face velocity	[m/s]	1,6			1,6			
Normal external pressure	[Pa]	250			250			
Internal pressure drop of ventilation components	[Pa]	252/192			252/192			
Static efficiency of fans used in accordance with Regulation (EU) No 327/2011	[%]	53/51			53/51			
Declared maximum internal leakage rates	[%]	3			3			
Declared maximum external leakage rates (CAL(R) @ +400 Pa)	[%]	1			1			
Declared maximum external leakage rates (CAL(R) @ -400 Pa)	[%]	1			1			
Filter class		C			C			
Visual filter warning		Pressure device			Pressure device			
Casing sound power level	[dB(A)]	63			63			
ERP compliance		2018			2018			
Internet address	https://select.salda.it							

PRODUCT NAME	AMBERAIR COMPACT S-R-5000				AMBERAIR COMPACT S-RS-5000			
	H-C1	H-E/E2-C1	H-CO-C1	H-DX-C1	H-C1	H-E/E2-C1	H-CO-C1	H-DX-C1
Topology	Bidirectional				Bidirectional			
Type of HRS	Regenerative				Regenerative			
Type of drive	Variable speed				Variable speed			
Thermal efficiency	[%]	80			81			
Nominal NRVU flow rate	[m³/s]	1,4			1,4			
Effective electric power input	[kW]	2,49		2,6	2,49		2,6	
SFPint	[W/(m³/s)]	832	830	820	820	855	853	844
Maximum internal SFP	[W/(m³/s)]	1103			1121			
Face velocity	[m/s]	1,8			1,8			
Normal external pressure	[Pa]	250			250			
Internal pressure drop of ventilation components	[Pa]	250/184			257/199			
Static efficiency of fans used in accordance with Regulation (EU) No 327/2011	[%]	53/51		54/51	54/53		55/53	
Declared maximum internal leakage rates	[%]	3			3			
Declared maximum external leakage rates (CAL(R) @ +400 Pa)	[%]	1			1			
Declared maximum external leakage rates (CAL(R) @ -400 Pa)	[%]	1			1			
Filter class		C			C			
Visual filter warning		Pressure device			Pressure device			
Casing sound power level	[dB(A)]	61			61			
ERP compliance		2018			2018			
Internet address	https://select.salda.it							

PRODUCT NAME	AMBERAIR COMPACT S-R-7000				AMBERAIR COMPACT S-RS-7000				
	H-C1	H-E/E2-C1	H-CO-C1	H-DX-C1	H-C1	H-E/E2-C1	H-CO-C1	H-DX-C1	
Topology	Bidirectional				Bidirectional				
Type of HRS	Regenerative				Regenerative				
Type of drive	Variable speed				Variable speed				
Thermal efficiency	[%]	80				81			
Nominal NRVU flow rate	[m³/s]	1,94				1,94			
Effective electric power input	[kW]	3,36		3,43		3,36		3,43	
SFPint	[W/(m³/s)]	810	806	797	797	862	858	849	849
Maximum internal SFP	[W/(m³/s)]	1020				1038			
Face velocity	[m/s]	1,8				1,8			
Normal external pressure	[Pa]	250				250			
Internal pressure drop of ventilation components	[Pa]	257/186				271/226			
Static efficiency of fans used in accordance with Regulation (EU) No 327/2011	[%]	56/53		57/53		57/58		58/58	
Declared maximum internal leakage rates	[%]	3				3			
Declared maximum external leakage rates (CAL(R) @ +400 Pa)	[%]	1				1			
Declared maximum external leakage rates (CAL(R) @ -400 Pa)	[%]	1				1			
Filter class		C				C			
Visual filter warning		Pressure device				Pressure device			
Casing sound power level	[dB(A)]	50				50			
ERP compliance		2018				2018			
Internet address	https://select.salda.it								

PRODUCT NAME	AMBERAIR COMPACT S-R-9000				AMBERAIR COMPACT S-RS-9000				
	H-C1	H-E/E2-C1	H-CO-C1	H-DX-C1	H-C1	H-E/E2-C1	H-CO-C1	H-DX-C1	
Topology	Bidirectional				Bidirectional				
Type of HRS	Regenerative				Regenerative				
Type of drive	Variable speed				Variable speed				
Thermal efficiency	[%]	80				81			
Nominal NRVU flow rate	[m³/s]	2,5				2,5			
Effective electric power input	[kW]	4,28		4,44		4,28		4,44	
SFPint	[W/(m³/s)]	755	755	749	749	787	786	782	782
Maximum internal SFP	[W/(m³/s)]	1008				1026			
Face velocity	[m/s]	1,8				1,8			
Normal external pressure	[Pa]	300				300			
Internal pressure drop of ventilation components	[Pa]	261/212				280/230			
Static efficiency of fans used in accordance with Regulation (EU) No 327/2011	[%]	62/64		63/64		64/66		65/66	
Declared maximum internal leakage rates	[%]	3				3			
Declared maximum external leakage rates (CAL(R) @ +400 Pa)	[%]	1				1			
Declared maximum external leakage rates (CAL(R) @ -400 Pa)	[%]	1				1			
Filter class		C				C			
Visual filter warning		Pressure device				Pressure device			
Casing sound power level	[dB(A)]	56		57		56		57	
ERP compliance		2018				2018			
Internet address	https://select.salda.it								

9.2. THE COMPONENTS OF THE AIR HANDLING UNITS

All the individual components are specified below in a simplified and diagrammatical description.

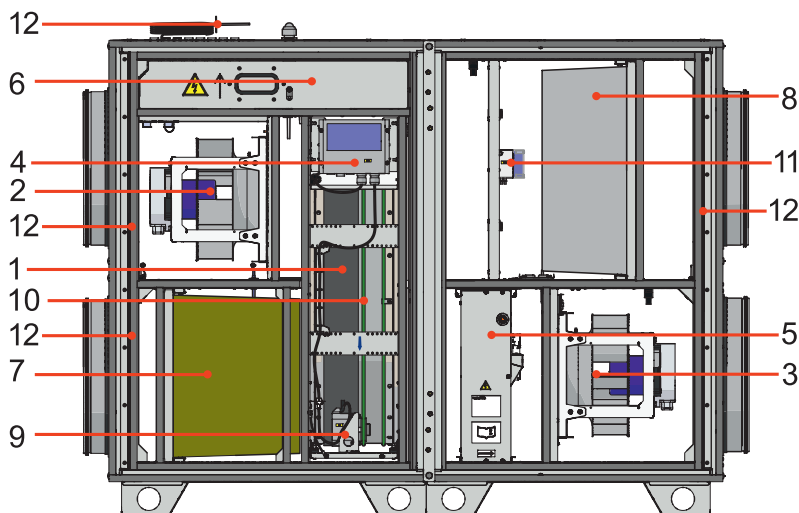

Fig. 9.2.1 AmberAir Compact S-R H

1 - Rotor heat exchanger; 2 - Exhaust fan; 3 - Supply fan; 4 - Heat exchanger motor drive; 5 - Heating/cooling coil; 6 - Control board; 7 - Supply air filter; 8 - Extract air filters; 9 - Rotor motor; 10 - Rotor belt; 11 - Pressure switch; 12 - Temperature sensor.

9.3. DISPOSAL

Old unit still have some residual value. An environmentally friendly method of disposal will ensure that valuable raw materials may be recovered and used again.



The danger of injury from sharp edges, sharp corners and thin sheet metal parts!

Separate the components for recycling into the following categories:

- Steel
- Aluminium
- Plastics
- Insulating materials
- Cables and wires
- Electronic scrap, e.g., circuit boards

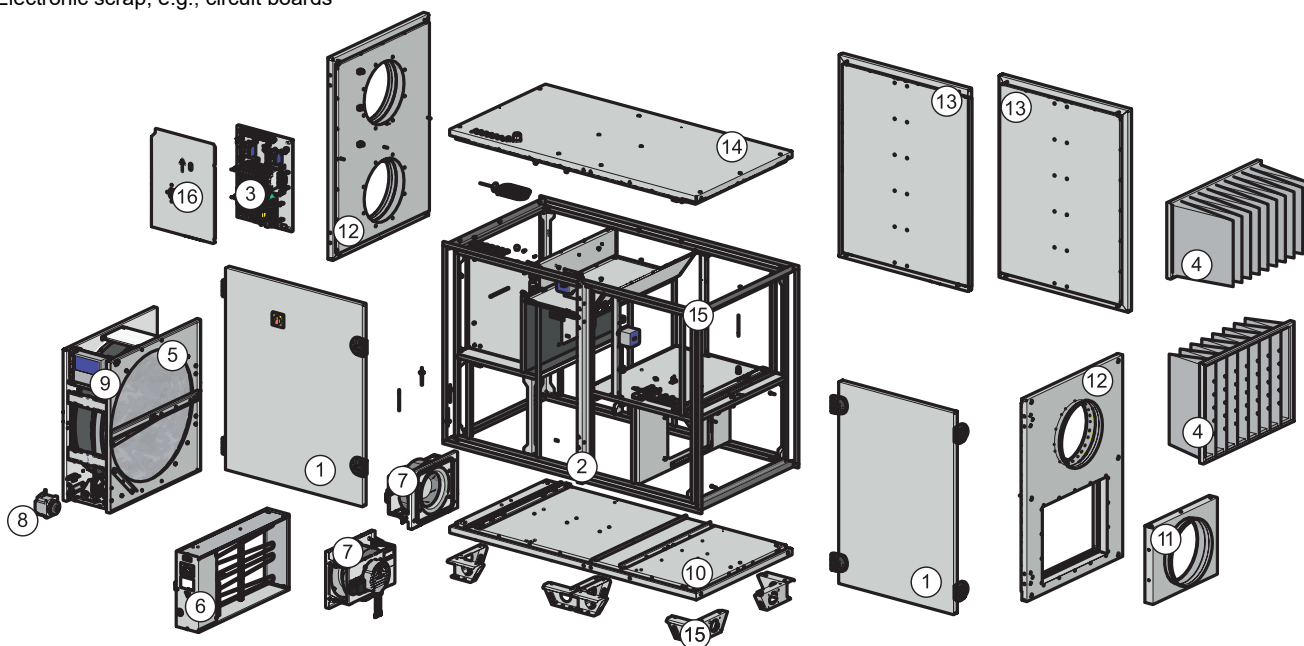

Fig. 9.3.1 AmberAir Compact S-R H

1 - Doors (metal and insulation); 2 - Front middle panel (metal and insulation); 3 - Control (electronic); 4 - Filter (metal and media); 5 - Heat exchanger (aluminium); 6 - Heater (metal and electronic); 7 - Fan (Metal, plastics and electronic); 8 - Heat exchanger motor (metal and electronic); 9 - Heat exchanger motor driver (electronic); 10 - Bottom panel (metal and insulation); 11 - Right door (metal and insulation); 12 - Side panels (metal and insulation); 13 - Back left door (metal and insulation); 14 - Top panel (metal and insulation); 15 - Support (Metal); 16 - Control cover (Metal).

9.4. DECLARATION OF CONFORMITY

Manufacturer

SALDA, UAB
Ragainės g. 100
LT-78109 Šiauliai, Lithuania
Tel.: +370 41 540415
www.salda.lt

Hereby confirms that the following products - Air Handling units:

AmberAir Compact*

(where by „*“ indicates possible unit installation type and modification)

provided it was delivered and installed in the facility in accordance with the included installation instructions, comply with all applicable requirements in the following directives:

Machinery Directive 2006/42/EC
EMC Directive 2014/30/EU
Low Voltage Directive 2014/35/EU
Ecodesign Directive 2009/125/EC
RoHS 2 Directive 2011/65/EU

The following regulations are applied in applicable parts:

Ecodesign requirements for ventilation units Nr. 1253/2014

The following harmonized standards are applied in applicable parts:

EN 1886:2009 - Ventilation for buildings - Air handling units - Mechanical performance.
EN 13053:2020 - Ventilation for buildings. Air handling units. Rating and performance for units, components and sections.
EN ISO 12100:2012 - Safety of machinery - General principles for design - Risk assessment and risk reduction.
EN 60204-1:2018 - Safety of machinery - Electrical equipment of machines - Part 1: General requirements.
EN 60335-1:2020 - Household and similar electrical appliances. Safety. Part 1: General requirements.
EN 60529:1999/A2:2014/AC:2019 - Degrees of protection provided by enclosures (IP code).
EN 61000-6-2:2019 - Electromagnetic compatibility (EMC) -- Part 6-2: Generic standards - Immunity for industrial environments.
EN 61000-6-3:2021 - Electromagnetic compatibility (EMC) -- Part 6-3: Generic standards - Emission standard for residential, commercial and light-industrial environments.

Should any alterations be made in the products, this declaration will no longer apply.

Quality: SALDA UAB activities are in line with the international quality management system standard **ISO 9001:2015**.

Date 2024-09-02



Giedrius Taujenis
Product manager

9.5. WARRANTY

To submit a warranty claim, you must be able to produce a completely documented and signed Service and Functionality Inspection Report of the product and accessories.

The Service and Functionality Inspection Report must be performed according to the instructions in Sections 4.1, 4.2 and 4.3.

General conditions for warranty liability are given in the delivery provisions applicable to the supply.

1. All equipment manufactured in our factory is checked in operating conditions and tested before delivery. The test protocol is supplied together with the unit. The equipment is shipped in good working condition to the end client. The unit is warranted for the period of two years from the date of the invoice.
2. If equipment is found to have been damaged during transportation, a claim should be made against the carrier, as we assume no responsibility for such damage.
3. This warranty does not apply:
 - 3.1. when transportation, storage, installation and maintenance instructions of the unit are violated;
 - 3.2. when the equipment is improperly maintained, mounted - inadequate maintenance;
 - 3.3. when the equipment without our knowledge and permission has been upgraded or unskilled repairs were made;
 - 3.4. when the unit was used not for its original purpose.
 - 3.5. Company SALDA UAB is not responsible for potential loss of property or personal injury in cases where the Air Handling unit is manufactured without the control system and the control system is installed by the client or the third parties. The manufacturer's warranty does not cover devices that will be damaged by installing the control system.
4. This warranty does not apply to these malfunction cases:
 - 4.1. mechanical damage;
 - 4.2. damage caused by entering outside objects, materials and liquids;
 - 4.3. damage caused by natural disasters, accidents (voltage change in the electricity network, lightning, etc.).
5. The company assumes no liability for the damage to its products neither directly nor indirectly, if the damage is caused by failure to comply with the installation and mounting regulations, deliberate or careless users or third-party behaviour.

These conditions are readily discernible when the equipment is returned to our factory for inspection.

If the direct client determines that equipment is found to be faulty, or a breakdown occurred, he should inform the manufacturer within five working days and deliver the equipment to the manufacturer. Delivery costs should be covered by the customer.

9.6. LIMITED WARRANTY COUPON

Warranty term
24 months*

I received the complete package and technical manual of the product ready for usage. I have read the warranty terms and conditions and agree with them:

.....
 Customer's signature

*Refer to WARRANTY CONDITIONS

Dear User, we appreciate your choice and do hereby guarantee that all ventilation equipment manufactured by our Company is inspected and thoroughly tested. An operational and high-quality product is sold to the direct buyer and shipped from the territory of the factory. It is provided with a 24-month warranty from the issue date of the invoice.

Your opinion is important to us, thus we always look forward to hearing your comments, feedback, or suggestions regarding technical and operational characteristics of the Products.

In order to avoid any misunderstandings, please read the instructions for installation and operation of the product as well as other technical documents of the product carefully. The number of the Limited Warranty Coupon and the serial number of the product specified on the silver identification sticker attached to the housing must match.

The Limited Warranty Coupon shall be valid provided that the seller's stamps and records are clear. It is not allowed to change, delete, or rewrite the data specified on it in any manner – such a coupon shall be invalid.

With this Limited Warranty Coupon the manufacturer confirms his obligations to implement the imperative requirements established by effective laws on protection of consumer rights in the event of identification of any defects of the products.

The manufacturer reserves the right to refuse provision of free warranty servicing in cases when the warranty conditions listed below are disregarded.

LINKS TO OTHER DOCUMENTS

MCB MANUAL



<https://select.salda.lt/file/mcb-en>

MB-GATEWAY QUICK LAUNCH GUIDE



<https://select.salda.lt/file/mb-gatewayen>

ST-SA-CONTROL MANUAL



<https://select.salda.lt/file/sa-control>

ST-SA-CONTROL QUICK LAUNCH GUIDE



<https://select.salda.lt/file/sac-ontrolqlg>

DE MANUAL



<https://select.salda.lt/file/amberrair-compact-s-r-h-de>

DK MANUAL



<https://select.salda.lt/file/amberrair-compact-s-r-h-dk>

FR MANUAL



<https://select.salda.lt/file/amberrair-compact-s-r-h-fr>

IT MANUAL



<https://select.salda.lt/file/amberrair-compact-s-r-h-it>

LT MANUAL



<https://select.salda.lt/file/amberrair-compact-s-r-h-lt>

LV MANUAL



<https://select.salda.lt/file/amberrair-compact-s-r-h-lv>

NL MANUAL



<https://select.salda.lt/file/amberrair-compact-s-r-h-nl>

NO MANUAL



<https://select.salda.lt/file/amberrair-compact-s-r-h-no>

PL MANUAL



<https://select.salda.lt/file/amberrair-compact-s-r-h-pl>

SE MANUAL



<https://select.salda.lt/file/amberrair-compact-s-r-h-se>

SK MANUAL



<https://select.salda.lt/file/amberrair-compact-s-r-h-sk>

UA MANUAL



<https://select.salda.lt/file/amberrair-compact-s-r-h-ua>



MAN000466

