

		Date	2024-12-10	Control board for AHU		= 219.2017	
		Ed.	justasbalys			+	
		Appr.				Project Nr.	
Modification	Date	Name	Original	Replacement of	Replaced by	Offer nr.	Page 1
							Page 1 / 17

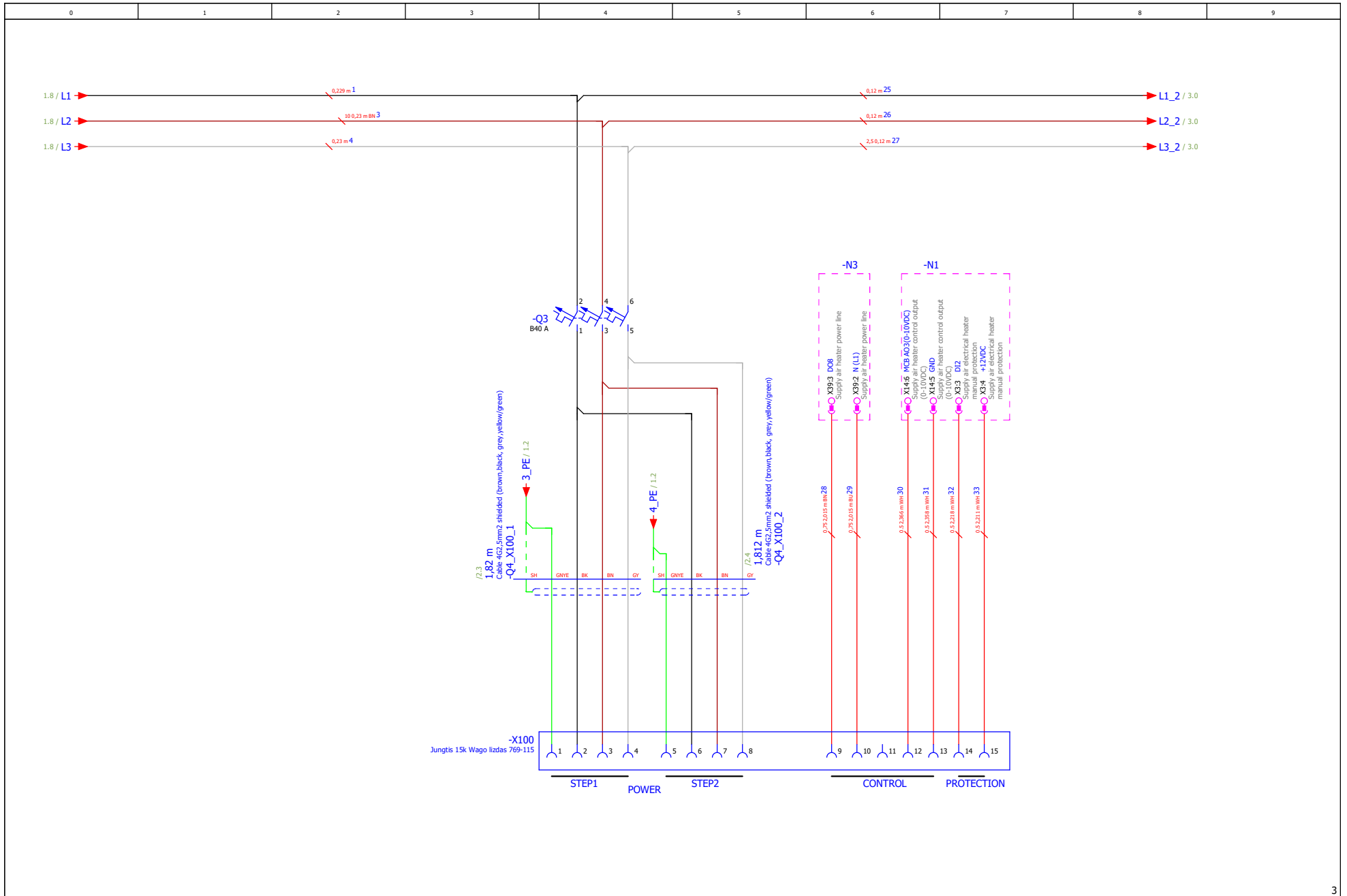

Power supply



		Date	2024-12-10	Control board for AHU				= 219.2017	
		Ed.	justasbalys					+	
		Appr.						Project Nr.	
Modification	Date	Name	Original	Replacement of	Replaced by	SALDA		Offer nr.	Page 2
						Heater		Page 2 / 17	

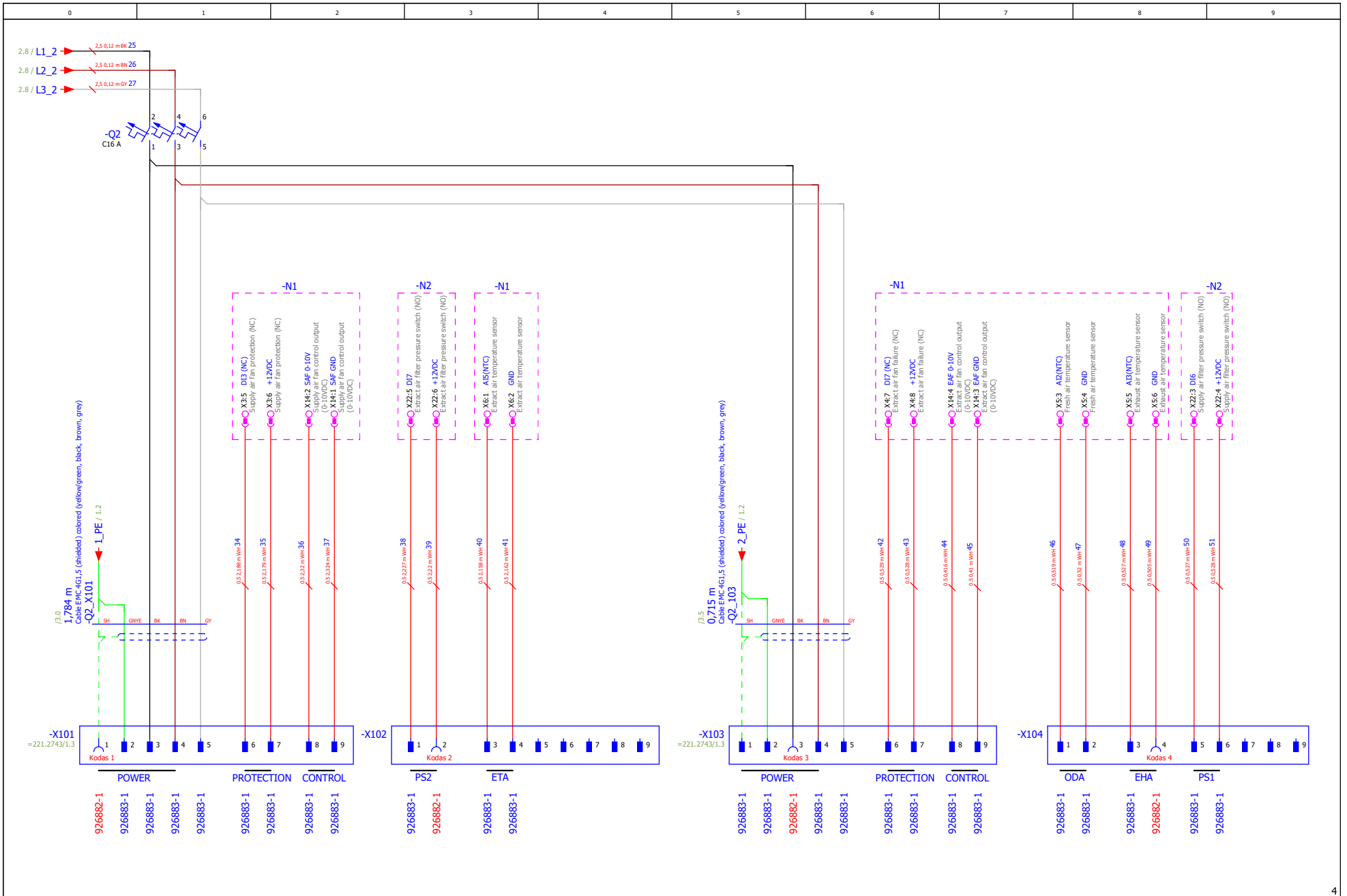

		Date	2024-12-10	Control board for AHU	
		Ed.	justasbalys		
		Appr.			
Modification	Date	Name	Original	Replacement of	Replaced by



Fans, Sensors, PS2		= 219.2017	
		+	
Project Nr.	Offer nr.	Page	3
		Page	3 / 17

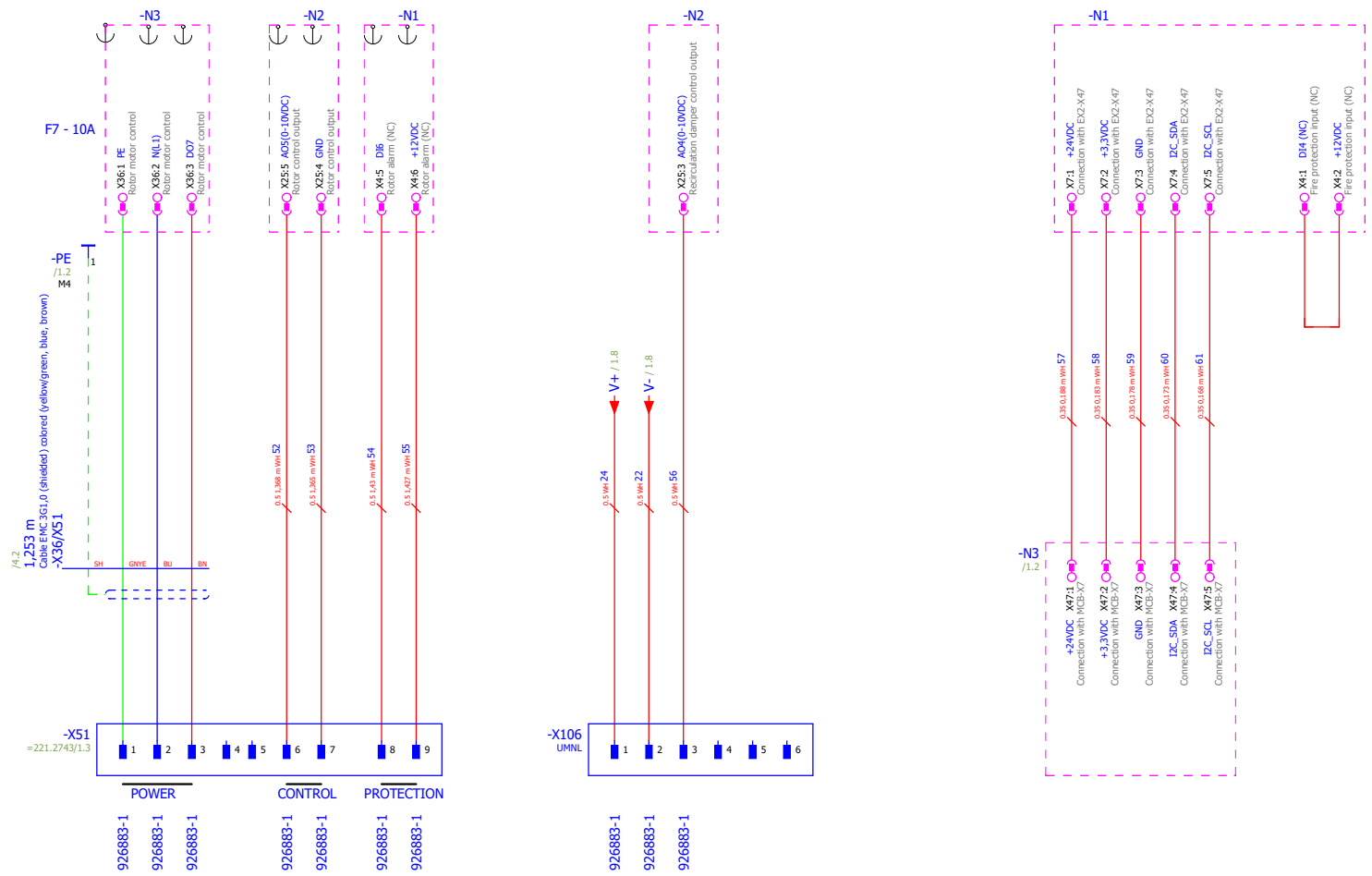

Modification	Date	Name	Original	Replacement of	Replaced by



Control board for AHU		Rotor, Communication, Recirculation		= 219.2017	
Ed. justasbalys				+	
Appr.				Project Nr.	
				Offer nr.	
				Page 4	
				Page 4 / 17	

- 926882-1
- 926882-1
- 926883-1
- 926882-1
- 926882-1
- 926884-1
- 926884-1
- 926884-1
- 926884-1

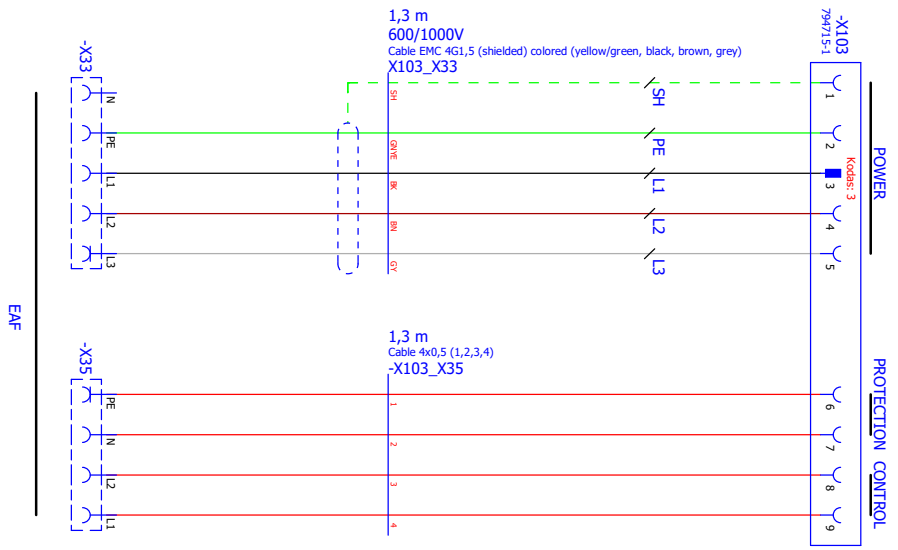

- 926884-1
- 926884-1
- 926884-1
- 926885-1
- 926884-1
- 926884-1

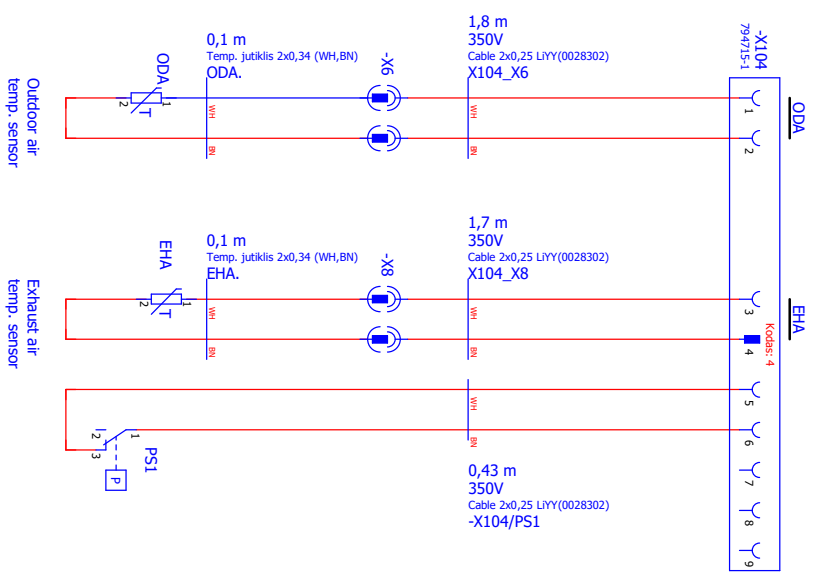

Modification	Date	Name	Date	Original	Replacement of	Replaced by
			2024.06.11	Edr. justasabálys		
SALDA						
Z21.2744.2.FS						
Project Nr.	Offer nr.		= Z21.2744			
			+			
			Page 2 / 13			

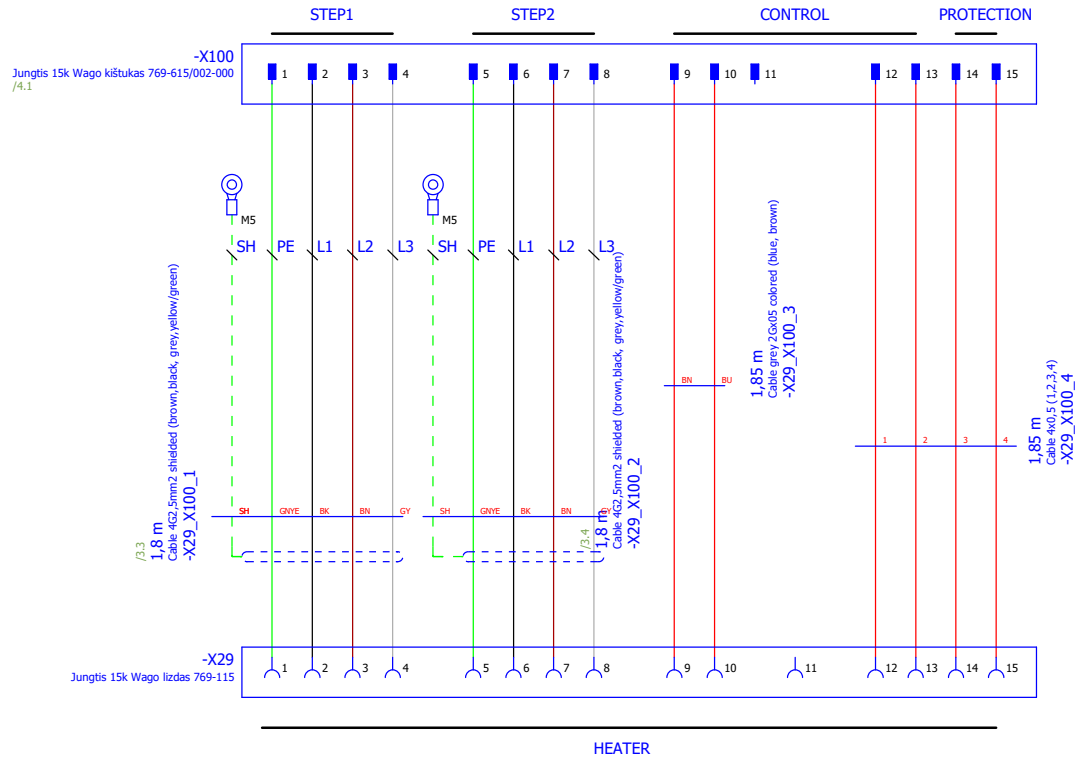

			Date	2024-06-11
			Ed.	justasbalsys
			Appr.	
Modification	Date	Name	Original	
			Replacement of	Replaced by



221.2744.3-PS

		= 221.2744	
		+	
Project Nr.	Offer nr.	Page	3
		Page	3 / 13

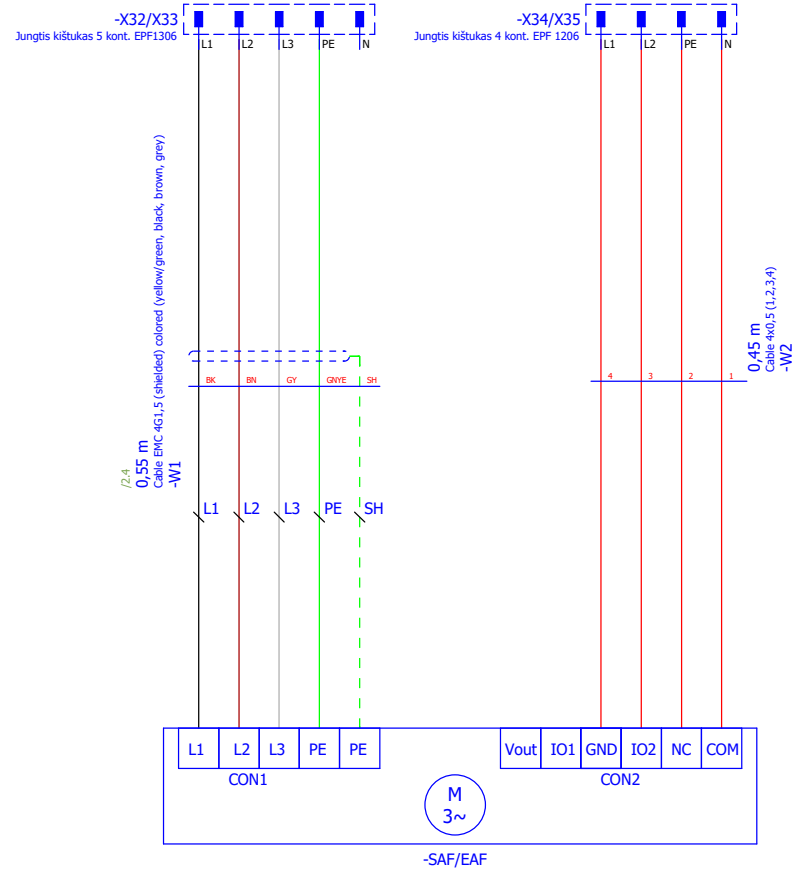

				Date	2024-04-17	Harness for fan		= 221.2470	
				Ed.	justasbalsys			+	
				Appr.				Project Nr. 221-2375	
Modification	Date	Name	Original	Replacement of	Replaced by			Offer nr.	Page 2
						221.2470-PS		Page 1 / 3	

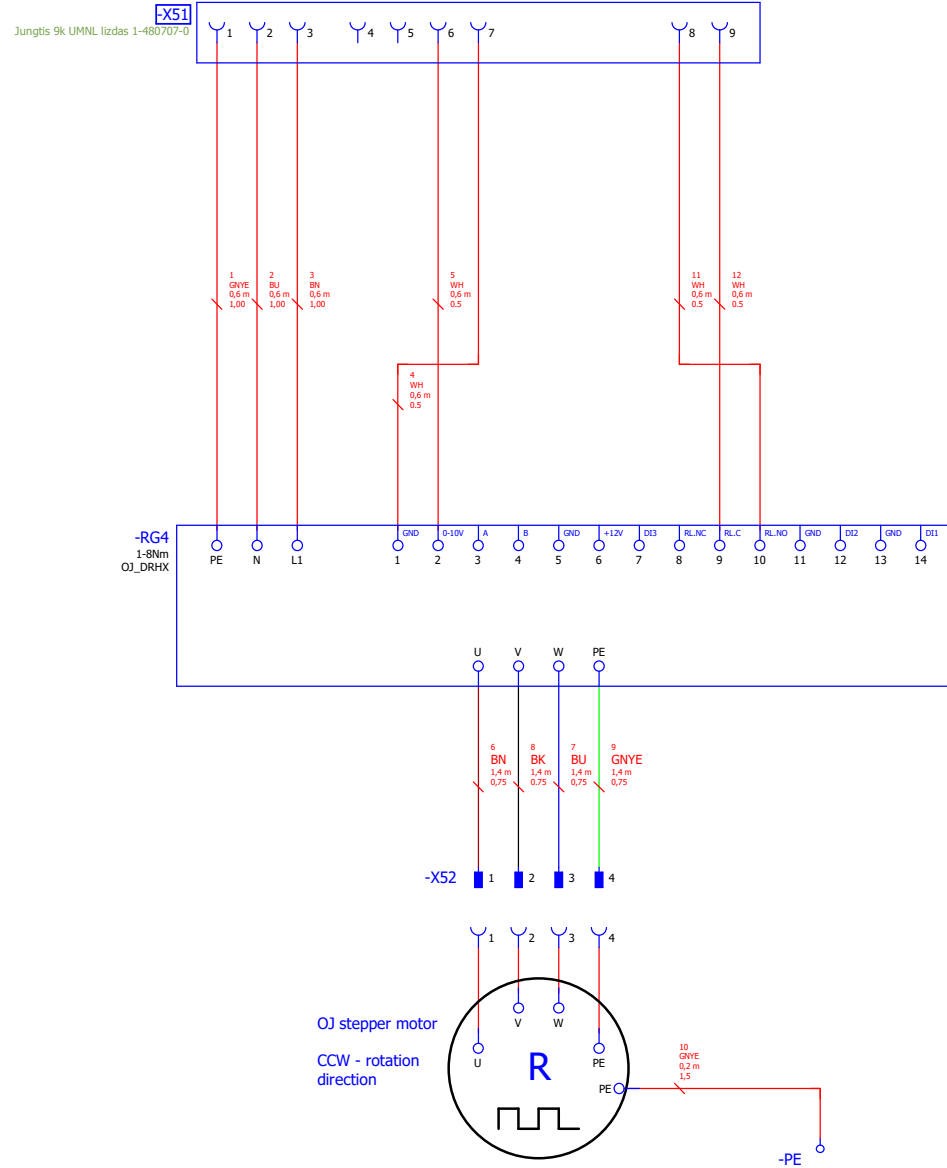

		Date	2024-04-17	Harness for rotor			221.2473-PS	= 221.2473	
		Ed.	justasbalsys					+	
		Appr.						Project Nr.	Offer nr.
Modification	Date	Name	Original	Replacement of	Replaced by			Page	1 / 3

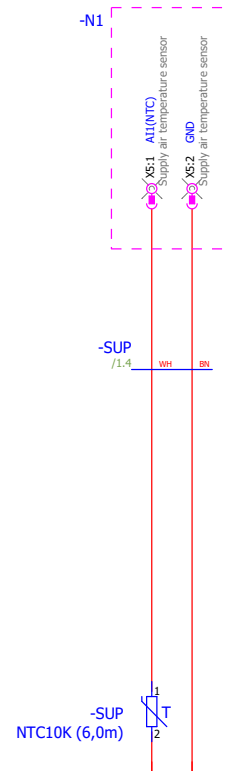

			Date	2023-01-20		
			Ed.	justasbalys		
			Appr.			
Modification	Date	Name	Original	Replacement of	Replaced by	



SUP to MCB

		= SP150 (SUP connection to MCB)
		+
Project Nr.	Offer nr.	Page 1 / 1