

SAF

EAF

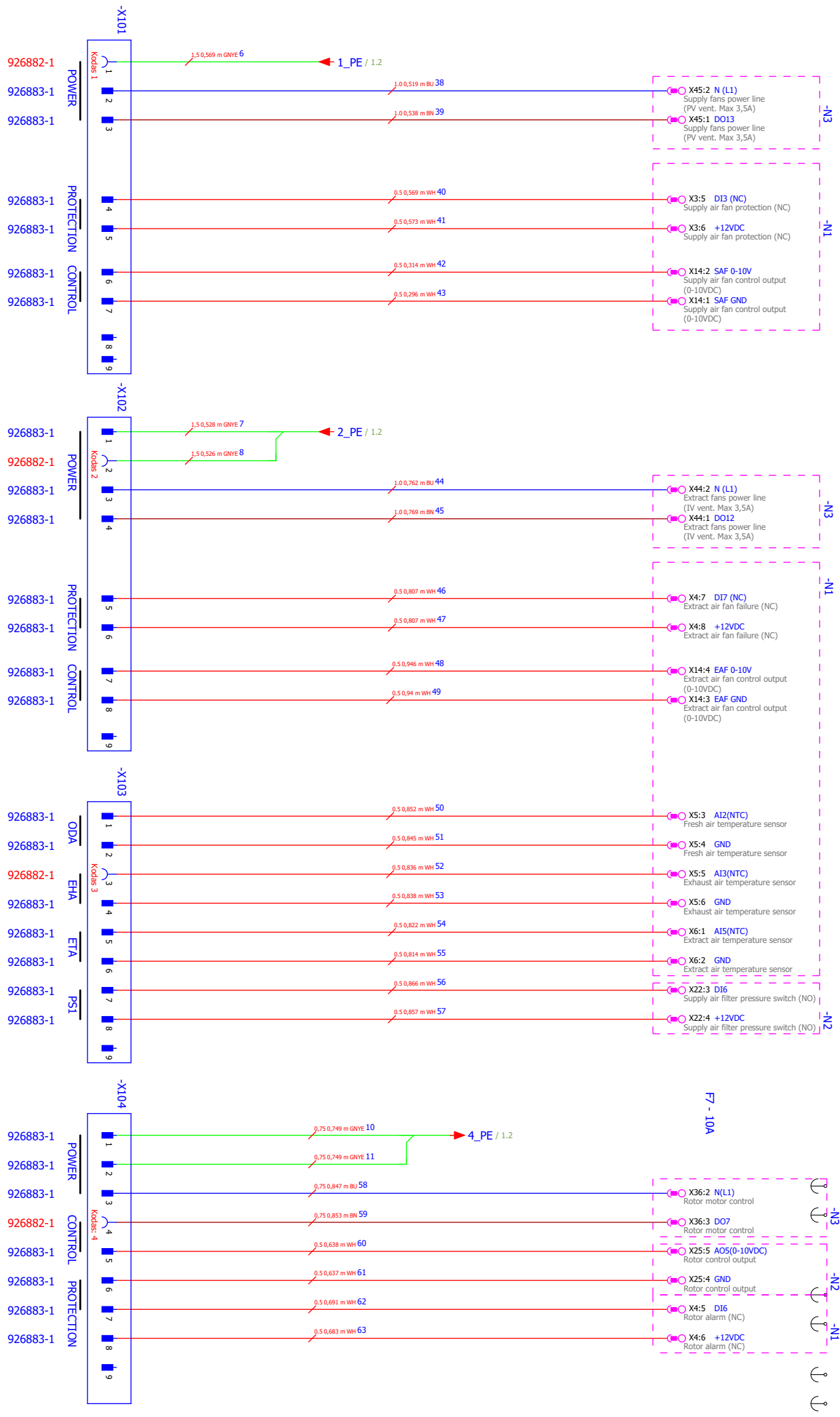

F1 - 10A

Modification		Date	2024-03-23
Date		Ed.	Vidas Petrulis
Name		Appr.	
Control board for AHU			
Replacement of		Replaced by	
			
PS2 wires, Communication			
Project Nr.		Offer nr.	
= 219.1837		Page	4
		Page	4 / 13

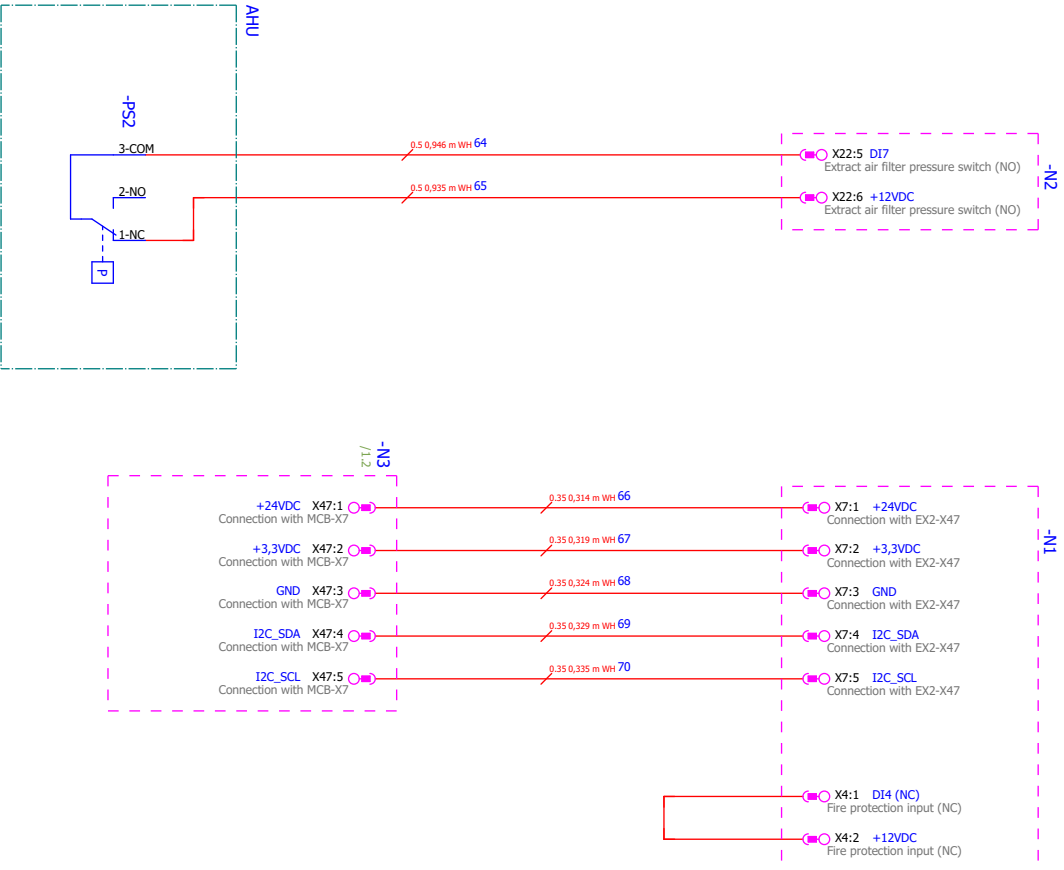

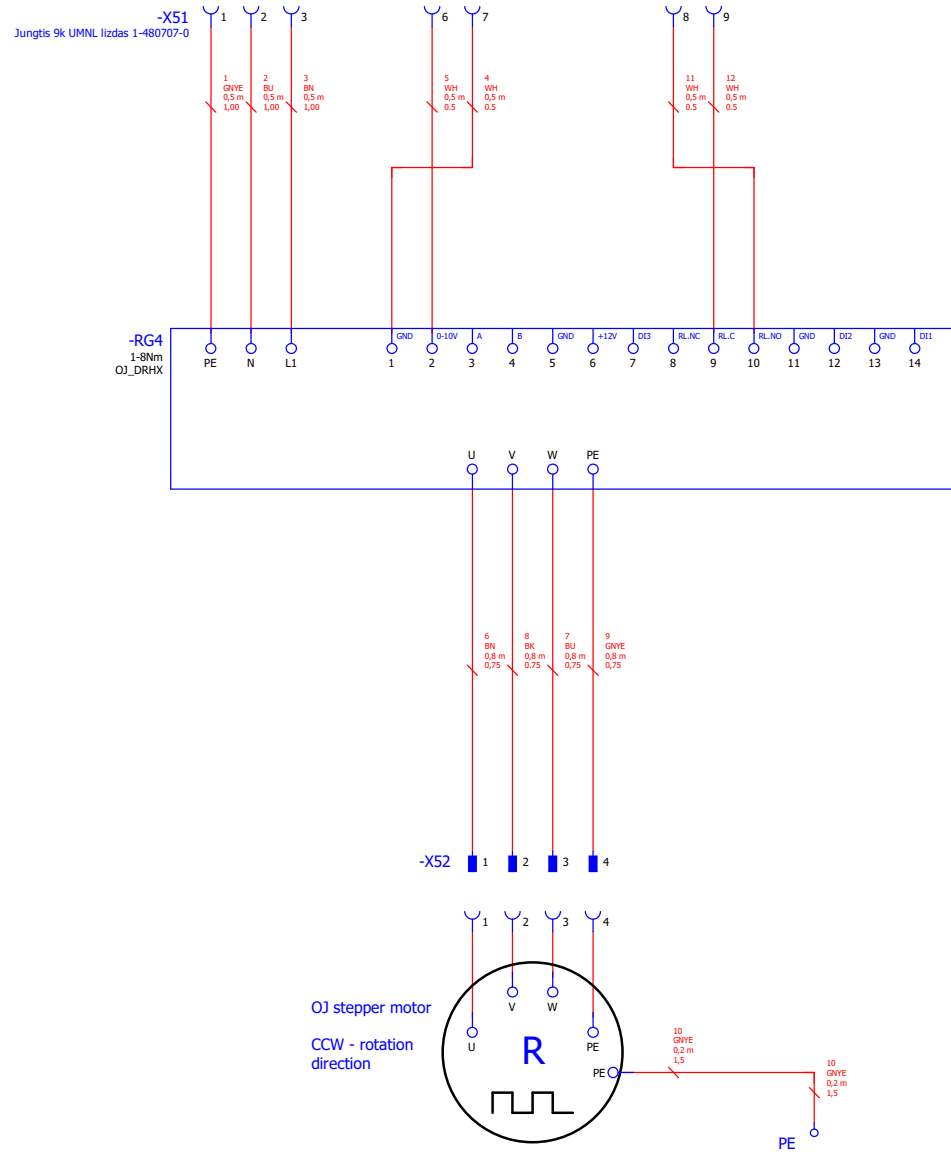

			Date	2023-10-24		221.2189.1-PS	= 221.2189		
			Ed.	justasbalsys			+		
			Appr.				Project Nr.	Offer nr.	Page
Modification	Date	Name	Original		Replacement of	Replaced by		Page	1 / 3

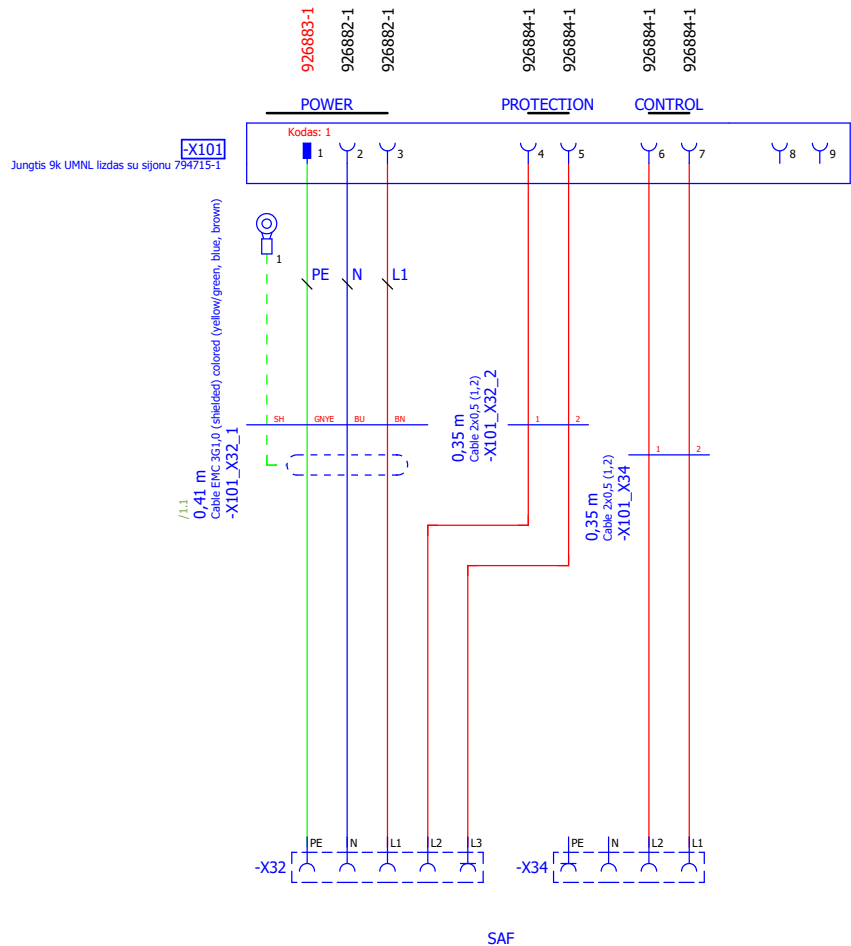

X101
Jungtis 9k UMNL lizdas su sijonu 794715-1

SAF

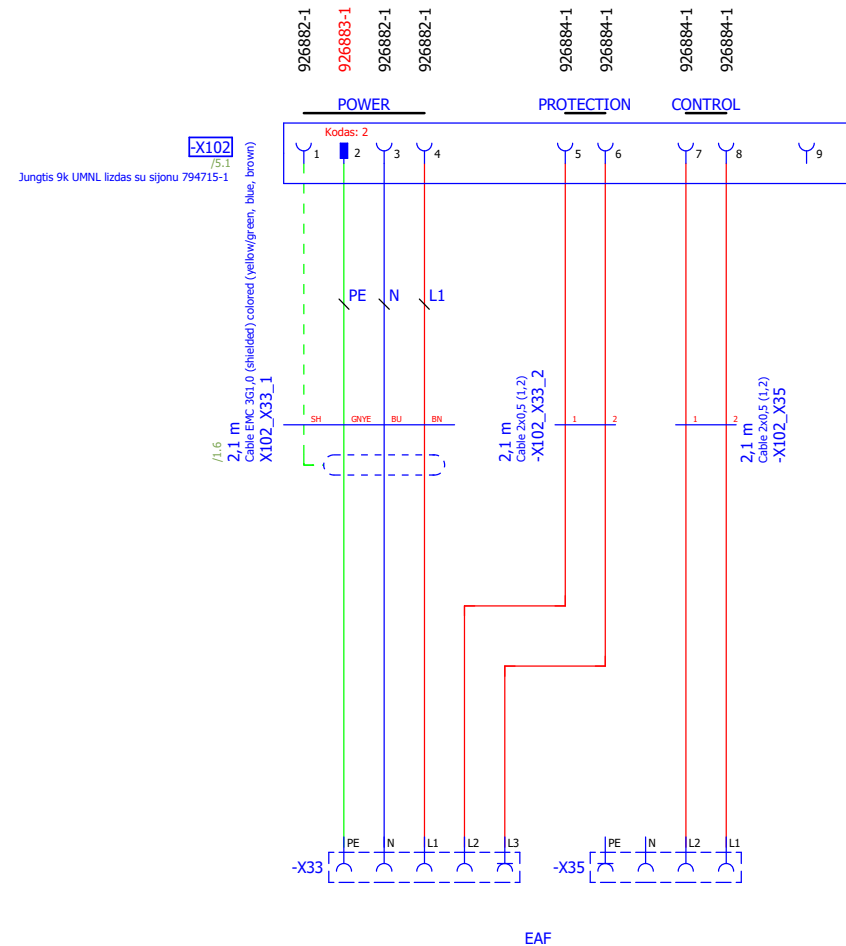

X102
Jungtis 9k UMNL lizdas su sijonu 794715-1

EAF

			Date	2024-02-13	Harness for AHU	
			Ed.	justasbalsys		
			Appr.			
Modification	Date	Name	Original		Replacement of	Replaced by



221.2457.1-PS

		= 221.2457	
		+	
Project Nr.	Offer nr.	Page	1
		Page	1 / 13

Jungtis 9k U/MNL Izdas su signu /2/7/15-1

X103

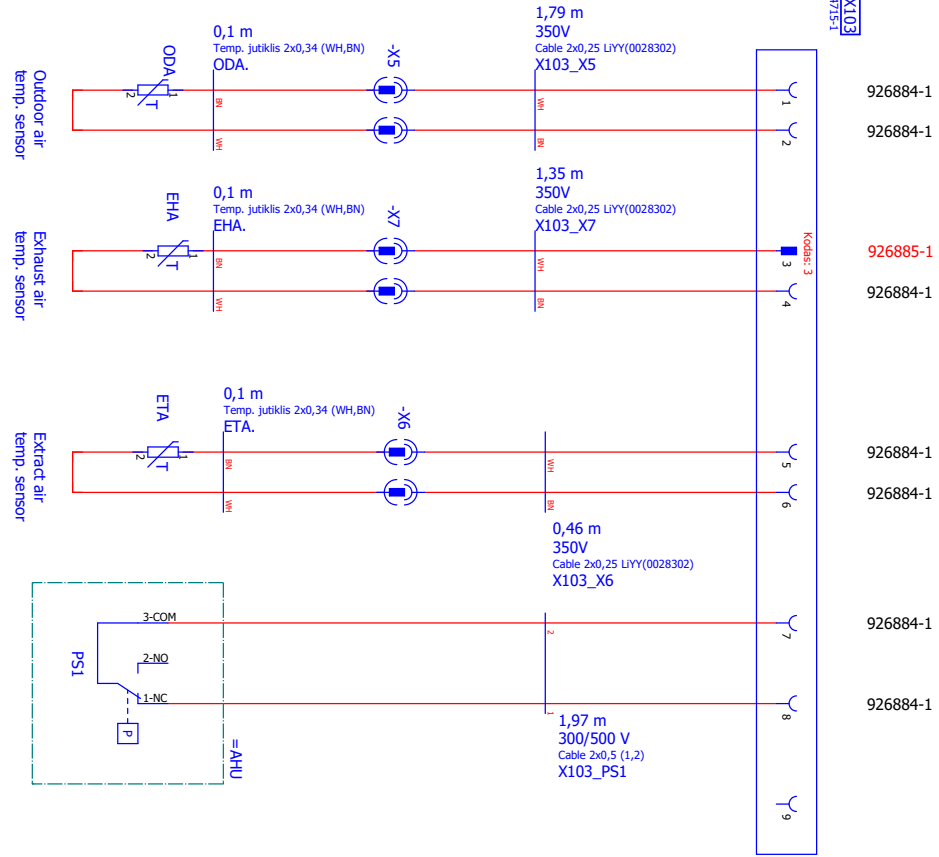

Jungtis 9k U/MNL Izdas su signu /2/7/15-1

X104

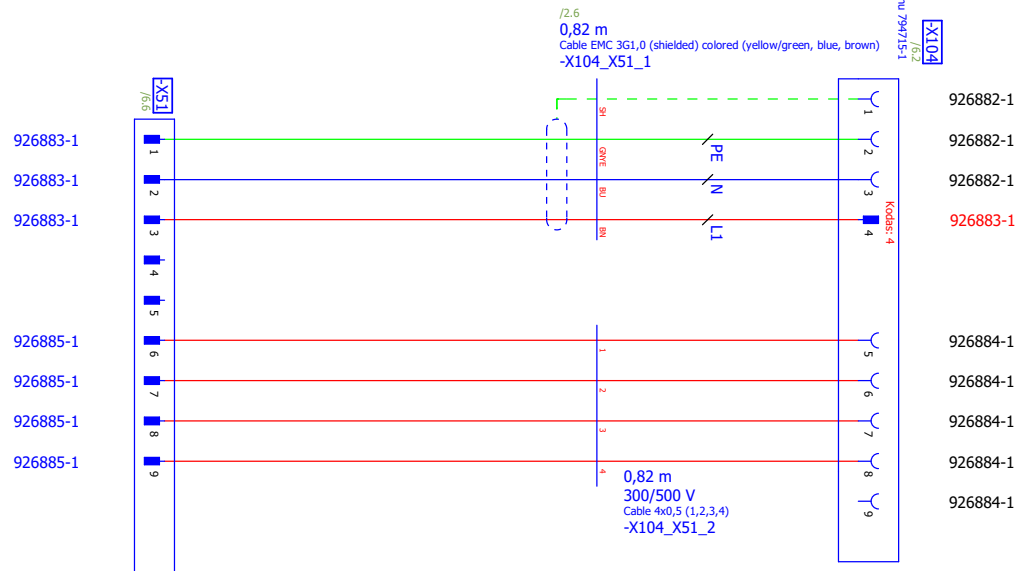

Modification	Date	Name	Date	Ed.	Apr.	Original	Replacement of	Replaced by
			2024-02-14	justasabrys			Harness for AHU	



Z21_2457_2-PS

Project Nr.	Offer nr.	+ = Z21_2457
		Page 2 / 13

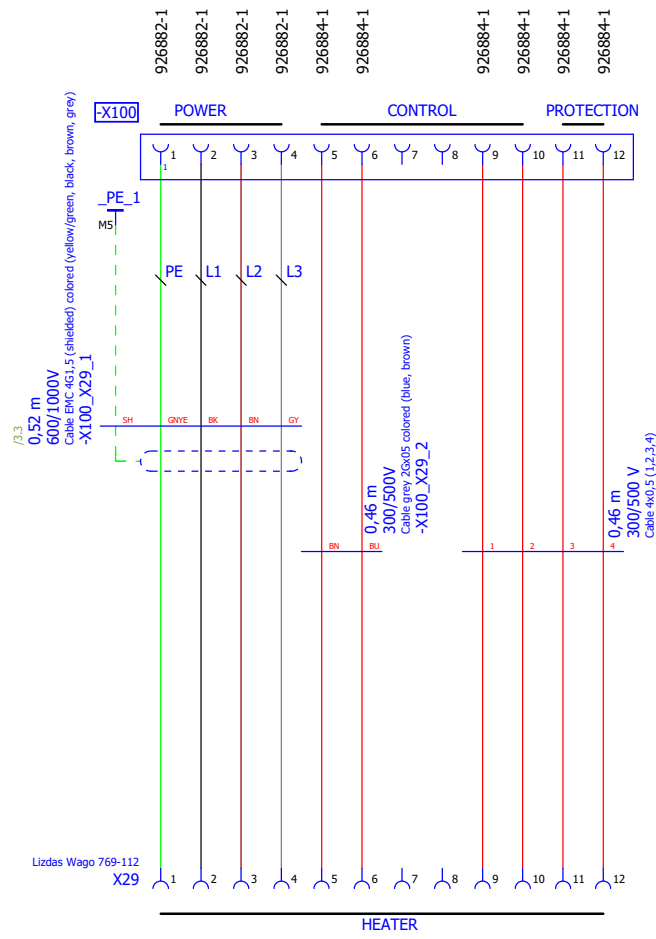

			Date	2024-04-26	Harness for AHU		221.2457.1-PS	= 221.2457	
			Ed.	justasbalsys				+	
			Appr.					Project Nr.	Offer nr.
Modification	Date	Name	Original		Replacement of	Replaced by		Page	3 / 13

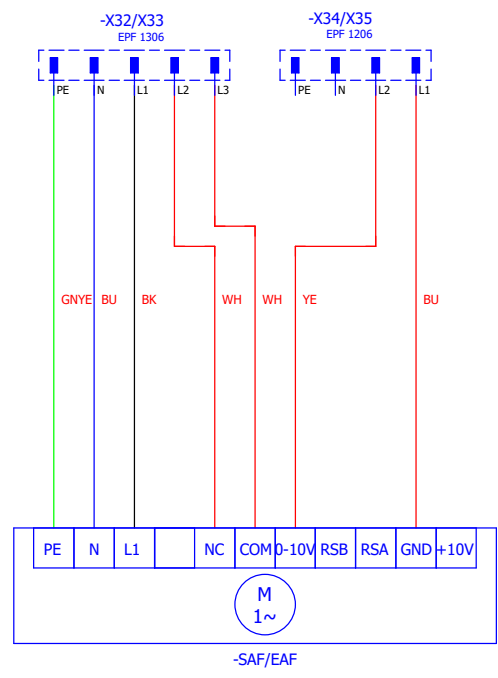

			Date	2023-03-08		
			Ed.	justasbalys		
			Appr.			
Modification	Date	Name	Original		Replacement of	Replaced by



Fans

Project Nr.	Offer nr.
-------------	-----------

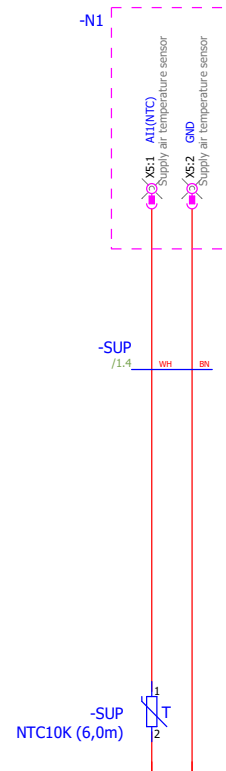

Control board

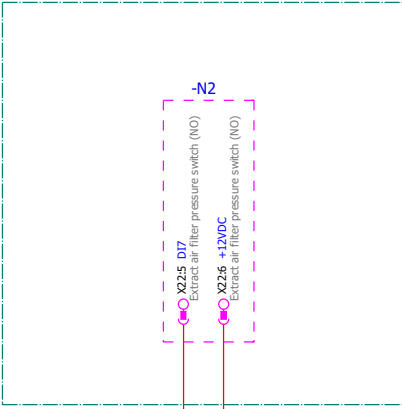

NOTE: Wires comes from the control board



PS600

Control board

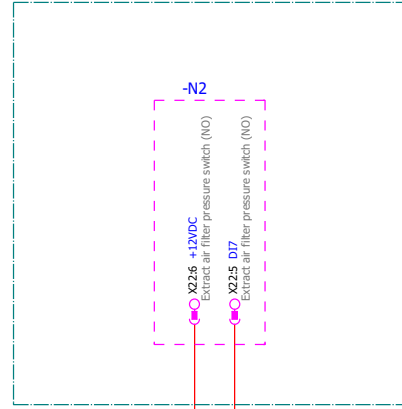

NOTE: Wires comes from the control board

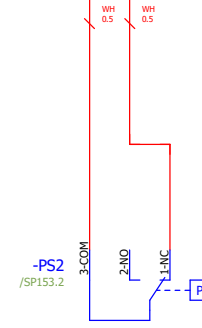

DPR500

			Date	2023-12-07	SP153	
			Ed.	Vidas.Petraitis		
			Appr.			
Modification	Date	Name	Original		Replacement of	Replaced by



AAC S-R V MCB PS2 connection

		=
		+
Project Nr.	Offer nr.	
		Page SP153
		Page 1 / 1

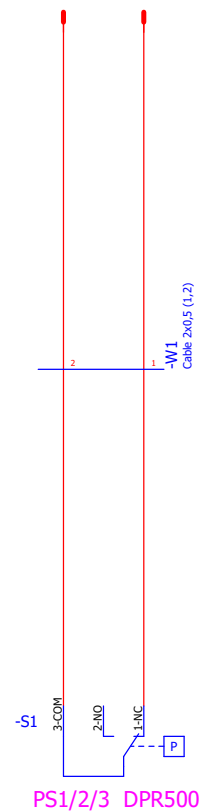
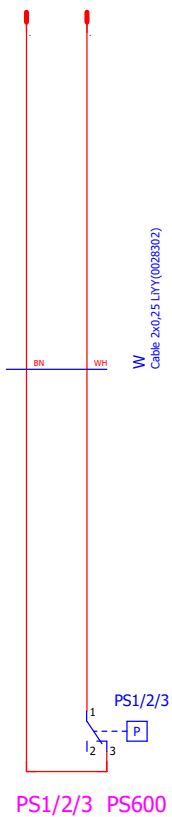

			Date	2023-12-05	SP158
			Ed.	Vidas.Petruitis	
			Appr.		
Modification	Date	Name	Original	Replacement of	Replaced by



PS1/2/3 connection to harness (MCB)

			=
			+
Project Nr.	Offer nr.	Page	SP158
		Page	1 / 1

